

**Ambient SO<sub>2</sub> monitor  
APSA-370**

**Operation Manual**

CODE:GZ0000051251C

## Preface

This manual describes the operation of the Ambient SO<sub>2</sub> monitor, APSA-370.

Be sure to read this manual before using the product to ensure proper and safe operation of the instrument. Also safely store the manual so it is readily available whenever necessary.

Product specifications and appearance, as well as the contents of this manual are subject to change without notice.

## ■ Warranty and Responsibility

HORIBA warrants that the Product shall be free from defects in material and workmanship and agrees to repair or replace free of charge, at HORIBA's option, any malfunctioned or damaged Product attributable to HORIBA's responsibility for a period of one (1) year from the delivery unless otherwise agreed with a written agreement. In any one of the following cases, none of the warranties set forth herein shall be extended;

- Any malfunction or damage attributable to improper operation
- Any malfunction attributable to repair or modification by any person not authorized by HORIBA
- Any malfunction or damage attributable to the use in an environment not specified in this manual
- Any malfunction or damage attributable to violation of the instructions in this manual or operations in the manner not specified in this manual
- Any malfunction or damage attributable to any cause or causes beyond the reasonable control of HORIBA such as natural disasters
- Any deterioration in appearance attributable to corrosion, rust, and so on
- Replacement of consumables

HORIBA SHALL NOT BE LIABLE FOR ANY DAMAGES RESULTING FROM ANY MALFUNCTIONS OF THE PRODUCT, ANY ERASURE OF DATA, OR ANY OTHER USES OF THE PRODUCT.

## ■ Trademarks

Generally, company names and brand names are either registered trademarks or trademarks of the respective companies.

## Conformable Directive

This equipment conforms to the following directives and standards:



<b>Directives:</b>	the EMC Directive 2004/108/EC the Low Voltage Directive 2006/95/EC
<b>Standards:</b>	[the EMC Directive] EN61326-1: 2006 EMI Class B, EMS: Industry [the Low Voltage Directive] EN61010-1: 2001

### ● Installation Environment

This product is designed for the following environment.

- Installation Categories II
- Pollution degree 2

### ● Information on Disposal of Electrical and Electronic Equipment and Disposal of Batteries and Accumulators

The crossed out wheeled bin symbol with underbar shown on the product or accompanying documents indicates the product requires appropriate treatment, collection and recycle for waste electrical and electronic equipment (WEEE) under the Directive 2002/96/EC, and/or waste batteries and accumulators under the Directive 2006/66/EC in the European Union.

The symbol might be put with one of the chemical symbols below. In this case, it satisfies the requirements of the Directive 2006/66/EC for the object chemical.

This product should not be disposed of as unsorted household waste.

Your correct disposal of WEEE, waste batteries and accumulators will contribute to reducing wasteful consumption of natural resources, and protecting human health and the environment from potential negative effects caused by hazardous substance in products.

Contact your supplier for information on applicable disposal methods.

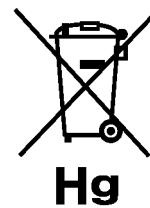
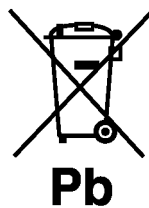
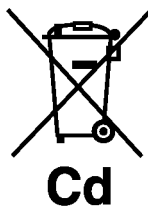
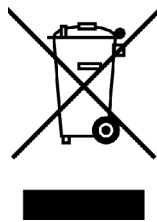

## FCC Rules

Any changes or modifications not expressly approved by the party responsible for compliance shall void the user's authority to operate the equipment.

### ■ Note

This equipment has been tested and found to comply with the limits for a Class B digital device, pursuant to part 15 of the FCC Rules. These limits are designed to provide reasonable protection against harmful interference in a residential installation. This equipment generates, uses, and can radiate radio frequency energy and, if not installed and used in accordance with the instructions, may cause harmful interference to radio communications. However, there is no guarantee that interference will not occur in a particular installation. If this equipment does cause harmful interference to radio or television reception, which can be determined by turning the equipment off and on, the user is encouraged to try to correct the interference by one or more of the following measures:

- Reorient or relocate the receiving antenna.
- Increase the separation between the equipment and receiver.
- Connect the equipment into an outlet on a circuit different from that to which the receiver is connected.
- Consult the dealer or an experienced radio/TV technician for help.

## For your safety

Warning messages are described in the following manner. Read the messages and follow the instructions carefully.

### ● Meaning of warning messages



This indicates an imminently hazardous situation which, if not avoided, will result in death or serious injury. This signal word is to be limited to the most extreme situations.



This indicates a potentially hazardous situation which, if not avoided, could result in death or serious injury.



This indicates a potentially hazardous situation which, if not avoided, may result in minor or moderate injury. It may also be used to alert against unsafe practices.

Without safety alert indication of hazardous situation which, if not avoided, could result in property damage.

### ● Symbols







Description of what should be done, or what should be followed



Description of what should never be done, or what is prohibited

## ■ Safety Precautions

This section provides precautions to enable you to use the product safely and correctly and to prevent injury and damage. The terms of DANGER, WARNING, and CAUTION indicate the degree of imminency and hazardous situation. Read the precautions carefully as it contains important safety messages.

 <b>WARNING</b>	
	<b>HOT COMPONENT</b> Hot parts inside can burn you. Disconnect power before opening cover and wait for component cool down.
	<b>ELECTRICAL</b> Opening the cover while powered on could result in electric shock. Be sure to turn OFF power prior to opening the cover.
	Maintain ground to avoid electric shock.

## Disposal of the product

When disposing of the product, follow the related laws and/or regulations of your country for disposal of the product.

## Description in this manual

### Note

This interprets the necessary points for correct operation and notifies the important points for handling the unit.

### Reference

This indicates the part of where to refer the information.

### Tip

This indicates reference information.

# Contents

---

<b>1</b>	<b>OVERVIEW</b> .....	<b>1</b>
1.1	Introduction .....	1
1.2	System Configuration .....	1
1.3	Part Names .....	2
1.3.1	Front panel .....	2
1.3.2	Rear panel .....	3
<b>2</b>	<b>BASIC OPERATIONS</b> .....	<b>4</b>
2.1	Start-up (Measurement Start) .....	4
2.2	Shutdown .....	5
2.3	Basic Operation Flow .....	6
<b>3</b>	<b>MEAS. SCREEN (BASIC SCREEN)</b> .....	<b>7</b>
<b>4</b>	<b>CALIBRATION</b> .....	<b>11</b>
4.1	Calibration-related Screens .....	11
4.1.1	CAL. screen .....	11
4.1.2	MODE screen .....	12
4.1.3	Screens for value setting .....	13
4.2	Preparation for Calibration .....	14
4.2.1	Entering the span gas concentration value .....	14
4.3	Automatic Calibration (AIC) .....	16
4.3.1	AIC setting .....	16
4.3.2	Precautions in setting the AIC sequence .....	21
4.3.3	Setting the AIC sequence .....	22
4.3.4	Starting the AIC sequence with the [AIC] key .....	25
4.4	Manual Calibration .....	26
4.4.1	Operational flow .....	26
4.4.2	Zero calibration .....	27
4.4.3	Span calibration .....	28
4.4.4	Finishing calibration .....	29
<b>5</b>	<b>DATA PROCESSING</b> .....	<b>30</b>
5.1	Average .....	33
5.2	Integration .....	35
5.3	Rolling Average .....	37

<b>6</b>	<b>FUNCTIONALITIES</b>	<b>38</b>
6.1	Data Menu	40
6.2	History Menu	40
6.2.1	Calibration history	42
6.2.2	Alarm history	42
6.2.3	AIC history (optional)	43
6.3	Maintenance Menu	44
6.3.1	Analog output	44
6.3.2	Analog input	48
6.3.3	Hour meter	49
6.3.4	Lamp history	50
6.4	Range Menu	52
6.4.1	ANALOG OUTPUT 1 range (momentary value)	54
6.4.2	ANALOG OUTPUT 2 range (rolling average)	54
6.5	Setting Menu	55
6.5.1	Time adjustment	56
6.5.2	AIC setting	56
6.5.3	AIC sequence setting	56
6.5.4	Integration reset setting	57
6.5.5	Unit conversion factor	58
6.6	System Menu	60
6.6.1	LCD setting	60
6.6.2	Touch panel adjustment	62
6.6.3	Password setting	63
6.6.4	Data saving	65
6.7	Communication Menu	66
6.7.1	Machine ID setting	67
6.7.2	TCP/IP setting	70
6.8	Key Lock	75
<b>7</b>	<b>DAILY CHECKS</b>	<b>77</b>
7.1	Before Maintenance	77
7.2	Replacing the Filter Element	78
7.3	List of Consumables and Replacement Parts	79
<b>8</b>	<b>TROUBLESHOOTING</b>	<b>80</b>
8.1	Alarm Check	80
8.2	Alarm List	82
8.3	Troubleshooting	86



---

<b>9</b>	<b>EXTERNAL INPUT/OUTPUT .....</b>	<b>88</b>
9.1	Terminal Block Specifications .....	88
9.1.1	Range output for analog output .....	88
9.1.2	Contact input .....	88
9.1.3	Contact output .....	89
9.1.4	Alarm output .....	89
9.1.5	Analog output .....	89
9.1.6	Power shutoff output .....	89
<b>10</b>	<b>APPENDIX.....</b>	<b>90</b>
10.1	Measurement Principle .....	90
10.2	Specification .....	91
10.3	Unpacking .....	92
10.4	Installation .....	92
10.4.1	Installation environment .....	92
10.4.2	Installation place .....	92
10.5	Drawings .....	94



# 1 OVERVIEW

## 1.1 Introduction

APSA-370 is an ambient sulfur dioxide (SO<sub>2</sub>) monitor using the ultraviolet fluorescent (UVF) method as its operating principle. This monitor allows you to continuously measure the concentrations of SO<sub>2</sub> in the atmosphere.

As the analog output of concentrations, you can select either the combination of momentary value and rolling average or that of momentary value and average (optional). The default setting is the combination of momentary value and rolling average.

Addition of an RS-232C port (optional) will allow you to carry out data communication.

## 1.2 System Configuration

APSA-370 is a standalone system that allows you to operate it by merely connecting calibration gas dilution unit.

The system can be upgraded by connecting a computer, monitor, recorder, calibration gas cylinder.

The system configuration of APSA-370 is shown in the following diagram:

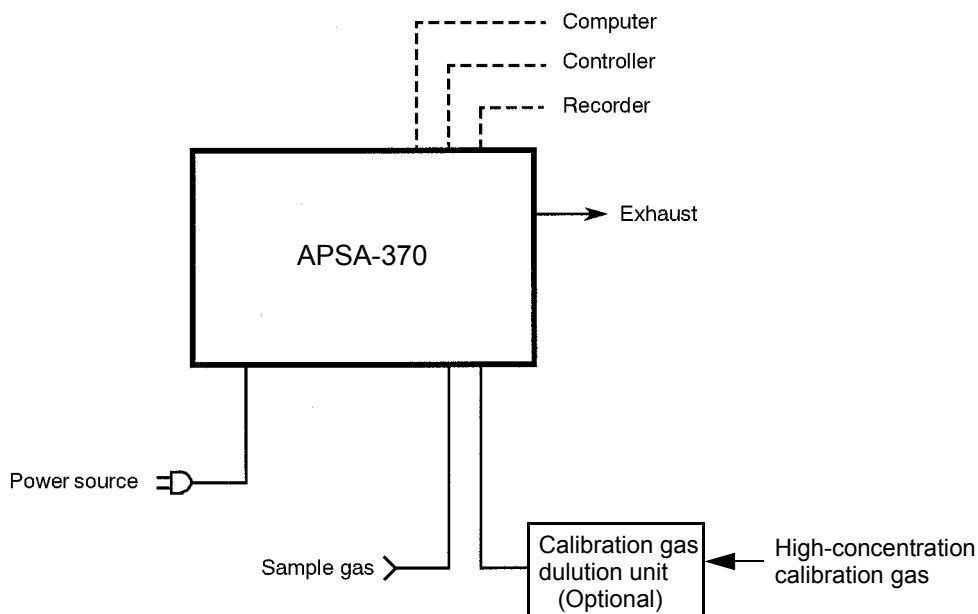
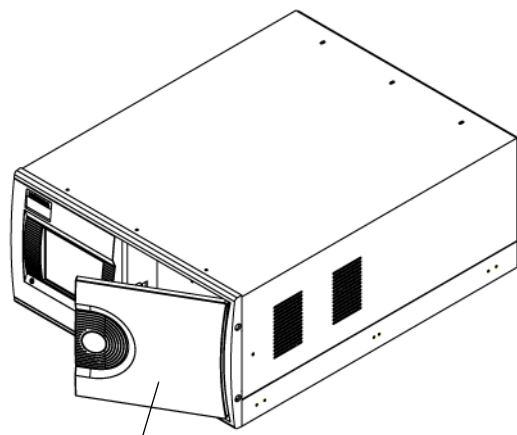

Fig. 1 System configuration

## 1.3 Part Names

### 1.3.1 Front panel



Front panel door

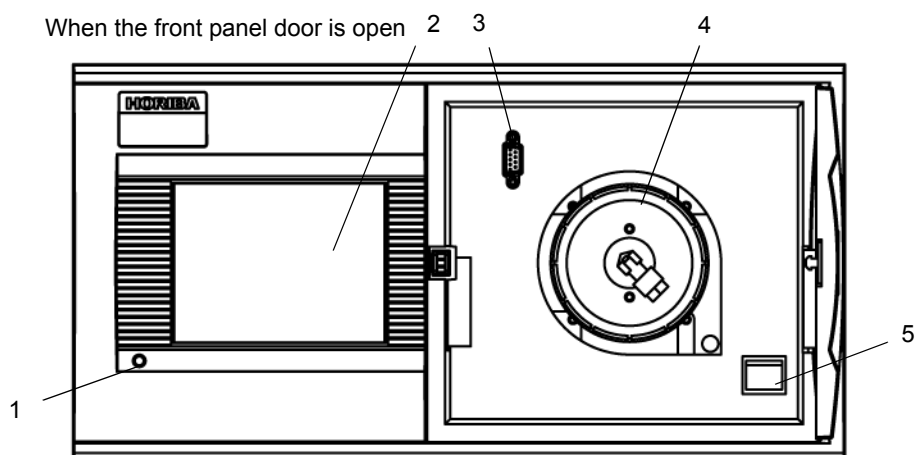

**Fig. 2 Front panel**

Name	Description
1 Power ON LED	When APSA-370 is ON, this LED is illuminated as follows: Green: During normal operation Red: In alarm conditions
2 Touch panel	Displays the measured values, alarms, etc. and touch-keys for operation.
3 RS-232C output port	Used for maintenance and adjustments.
4 Sample filter	A filter for the sample line. Replace this filter about every 2 weeks. (See " 7.2 Replacing the Filter Element " (page 78). The actual replacement frequency depends on the sample gas conditions.)
5 Power switch	Used to turn ON/OFF the main power supply.

### 1.3.2 Rear panel

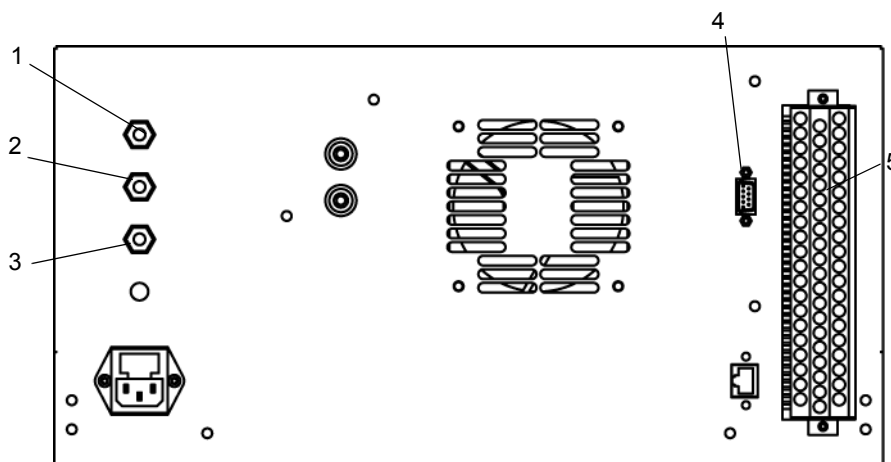

Fig. 3 Rear panel

Name	Description
1 Calibration gas inlet	The calibration gas inlet with a connector for a Teflon tube of 6 mm O.D./ 4 mm I.D. Make sure that the calibration gas pressure stays stable within $\pm 500$ Pa.
2 Sample inlet	The sample gas inlet with a connector for a Teflon tube of 6 mm O.D./ 4 mm I.D. Make sure that the sample gas pressure stays stable within $\pm 490$ Pa. In order to prevent condensation from occurring, exercise caution to ensure that the sample piping is not exposed to cool air.
3 Exhaust outlet	The measured gas outlet with a connector for a Teflon tube of 6 mm O.D./ 4 mm I.D. Release the measured gas to a safe location where the back pressure stays stable within a range of $\pm 490$ Pa.
4 RS-232C (optional)	
5 Signal connection terminal block	For the signals, see " 9 EXTERNAL INPUT/OUTPUT " (page 88).

#### Note

The measured gas is released from the exhaust outlet at a rate of 0.8 L/min.  
The SO<sub>2</sub> gas used for calibration is toxic. Be sure to connect an exhaust tube.

---

## 2 BASIC OPERATIONS

### 2.1 Start-up (Measurement Start)

#### 1. Power ON

Press the power switch located on the front panel to turn ON the main power supply. The MEAS. screen is automatically displayed and the measurement starts.

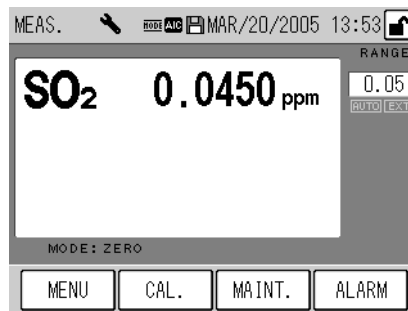

Fig. 4 Initial screen

#### 2. Warm-up

Wait for Warm up time (about 3 hours).

#### Note

- The [ALARM] key may be illuminated during warm-up, but this does not affect the warm-up process.  
If the [ALARM] key is still illuminated 3 hours later, see “ 8.2 Alarm List ” (page 82) to take action. Since the end of warm-up is not displayed, it is recommended to warm up at night or in any other time zone when the operation is not affected.
  - In order to obtain stable, accurate data, perform calibration at the measurement start and regular intervals (see “ 4 CALIBRATION ” (page 11)).
  - If the data logging capability (optional) for the CF is enabled, data logging is automatically executed when the APSA-370 is started again due to the power failure, etc.
-

---

## 2.2 Shutdown

**Note**

- The average and integration values are saved in the flash memory every 10 minutes. Before turning OFF the power, be sure to save the data in the memory (see “ 6.6.4 Data saving ” (page 65)).
- If power outage or a similar accident occurs, data may not be recorded for 10 minutes at a maximum.
- If the data logging capability (optional) for the CF is enabled, access to the CF will occur non-periodically. Be sure to disable the data logging capability before turning OFF the power, so that the power is not turned OFF during access to the CF. (Turning OFF the power during access to the CF may damage the data in CF.) (See the Instruction Manual for APXX-370 Series Compact Flash Memory.)

- 
1. Save the data in the memory (see “ 6.6.4 Data saving ” (page 65)).
  2. Ensure that the data logging capability is disabled during data logging (optional). (See the Instruction Manual for APXX-370 Series Compact Flash Memory.)
  3. Turn OFF the power of APSA-370.  
Before a long-term shutdown, it is recommended to replace the filter element (see “ 7.2 Replacing the Filter Element ” (page 78)).

## 2.3 Basic Operation Flow

To perform operations, ensure that the installation, wiring, and piping connections have been completed.

(Connect the external input/output as necessary.)

● **For the first use**

Power ON	Turn ON the power.	2.1 Start-up (Measurement Start) (page 4)
↓		
Setting	Unlock the keys*1	6.8 Key Lock(page 75)
	Set the current time.	6.5.1 Time adjustment(page 56)
	Set the start time, interval for calibration mode or operation using the internal clock.	4.3.1 AIC setting(page 16)
	Set the calibration sequence (zero span time).	4.3.3 Setting the AIC sequence(page 22)
↓		
Output setting	Set the analog output range (Fixed, Auto, or External). The default setting is "Auto." Select a desired mode in accordance with your use.	6.4 Range Menu(page 52)
↓		
Password change	The default value is 1234. Change this value as necessary.	6.6.3 Password setting(page 63)
↓		
Span gas/ calibration gas dilution unit connection	Connect the span gas line/ calibration gas dilution unit to be used and then check the connection.	
↓		
Span gas concentration entry	Enter the concentration of the span gas to be used.	4.2.1 Entering the span gas concentration value(page 14)
↓		
Calibration	Perform calibration automatically or manually.	4.3 Automatic Calibration (AIC)(page 16) 4.4 Manual Calibration(page 26)
↓		
Measurement	Perform the continuous measurement.	

\*1:The default password is 1234.



### 3 MEAS. SCREEN (BASIC SCREEN)

#### Note

APSA-370 uses a touch screen. Directly press keys displayed on that screen with your finger. When pressing these keys, do not use a ballpoint pen or any other tool with a hard or sharp end. This might cause a malfunction.

This chapter describes the MEAS. screen that is displayed immediately after the power is turned ON.

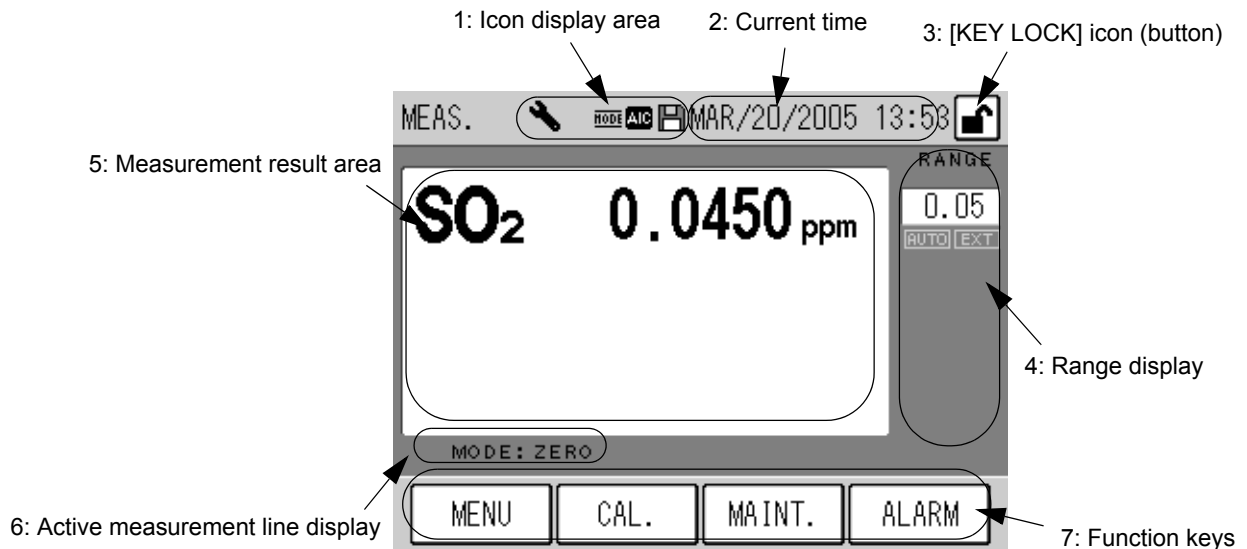

Fig. 5 MEAS. screen

#### 1: Icon display area

The icons showing the state of the instrument are displayed in this area.

Maintenance mode: This icon blinks when the maintenance switch is turned ON.

For the maintenance switch, see “ 7.1 Before Maintenance ” (page 77).



The maintenance switch is ON manually



The maintenance switch is ON under external control

Fig. 6 Maintenance mode icon

#### Note

In the case of the standard specifications, the MNT (Maintenance) signal is outputted when the maintenance switch is ON.

Mode: This icon is illuminated when gas is being sucked through any line other than the MEAS. line.

When the gas line is switched to the MEAS. line, this icon remains illuminated during the MEASURE time specified in the AIC sequence.



Fig. 7 Mode icon

AIC mode: This icon blinks when the AIC sequence is in progress.



**Fig. 8 AIC mode icon**

Saving: This icon is illuminated when data is being written to the flash memory or when the data logging capability (optional) is in use. Data is saved when any setting is modified or every 10 minutes during data acquisition.



**Fig. 9 Saving icon**

---

**Note**

When the Saving icon is displayed, do not turn OFF the power. If you do that, the data will not saved.

---

**2: Current time**

The current time is displayed.

For setting the current time, see “ 6.5.1 Time adjustment ” (page 56).

**3: [KEY LOCK] icon (button)**

The key locked/unlocked mode is displayed.

When this icon is displayed in a box, it works as the operation button of key lock/unlock.

In this state, pressing this button displays the KEY LOCK screen (Fig. 96 on page 75) allowing you to lock/unlock the keys.



Keys are locked



Keys are unlocked

**Fig. 10 [KEY LOCK] icon (button)**

When the keys are locked, you cannot operate with the screen; you can only view the screen. This prevents any wrong operation from causing a modification in the settings.

#### 4: Range display

The current range and range mode are displayed.

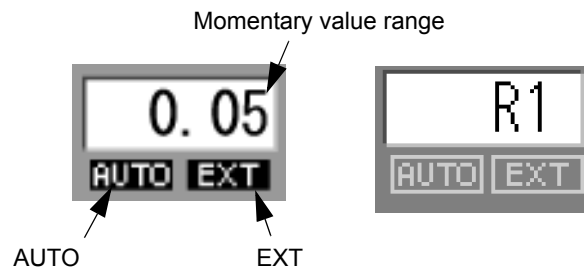

**Fig. 11 Range display**

**Momentary value range:** The current momentary value range is displayed. If the displayed unit is different from the factory setting, the range is changed to "RX." X: The concentration ranges are named as 1, 2, 3, and so forth in the ascending order.

**AUTO:** Displayed when the automatic range function is used.

**EXT:** Displayed when the external input for range switching is used.

#### Note

- For range setting, see " 6.4 Range Menu " (page 52).
- The external input of range switching can be controlled via contact input (optional) or the RS-232C port (optional).
- For changing the displayed unit, see "5: Measurement result area."

#### 5: Measurement result area

Measurement results are displayed.

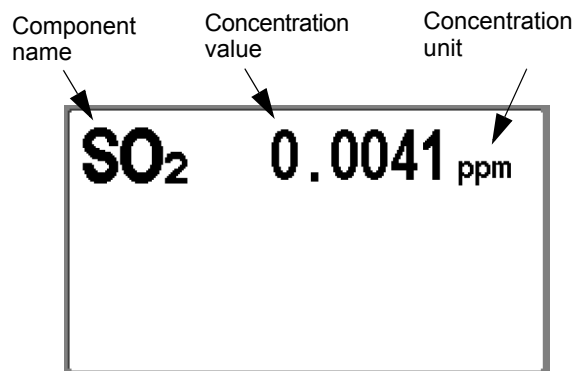

**Fig. 12 Measurement result area**

**Component name:** The name of the component under measurement is displayed.

**Concentration value:** The concentration value is displayed.

**Concentration unit:** The unit of the concentration value is displayed. The unit can be changed by touching the displayed unit when the keys are unlocked. You can switch between ppm and mg/m<sup>3</sup> or between ppb and µg/m<sup>3</sup>.

---

## 6: Active measurement line display

The currently selected measurement line is displayed.

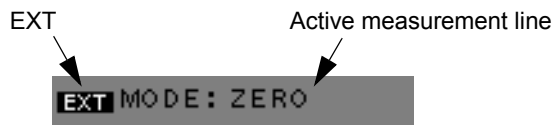

**Fig. 13 Active measurement line display**

EXT: Displayed when the external input for line switching is used.

Active measurement line: The currently selected measurement line is displayed.

- ZERO: The zero gas line is now being selected.
- SPAN: The span gas line is now being selected.
- MEAS.: The measured line is now being selected.

---

### Note

- For the external input of line switching, see “ 4.1.2 MODE screen ” (page 12).
  - The external input of line switching can be controlled via contact input (optional) or the RS-232C port (optional).
- 

## 7: Function keys

The keys allow you to perform the following operations.

[MENU]: The MENU screen (Fig. 47 on page 39) is displayed.

[CAL.]: The CAL. screen (Fig. 14 on page 11) is displayed.

[MAINT.]: The MAINTENANCE screen for operating the maintenance switch (Fig. 98 on page 77) is displayed.

[ALARM]: Displayed when an error occurs in the instrument.

Pressing the displayed [ALARM] key will allow you to view the current alarms.

For the details of alarms, see “ 8 TROUBLESHOOTING ” (page 80).

## 4 CALIBRATION

In order to acquire stable, accurate data, perform calibration when starting measurement and at regular intervals.

There are two types of calibration, the auto calibration (AIC) and the manual calibration.

### Auto calibration (AIC)

The AIC sequence is executed at the specified time intervals or with the externally inputted command to perform the zero calibration and span calibration automatically.

### Manual calibration

This calibration is performed manually at an arbitrary timing.

There are two methods available for the manual calibration; one uses the calibration gas line, and the other supplies the calibration gas to the measured gas line.

## 4.1 Calibration-related Screens

This section describes the screens used for the automatic calibration and manual calibration.

### 4.1.1 CAL. screen

This is the basic screen for calibration.

To display the CAL. screen, press the [CAL.] key on the MEAS. screen (Fig. 5 on page 7).

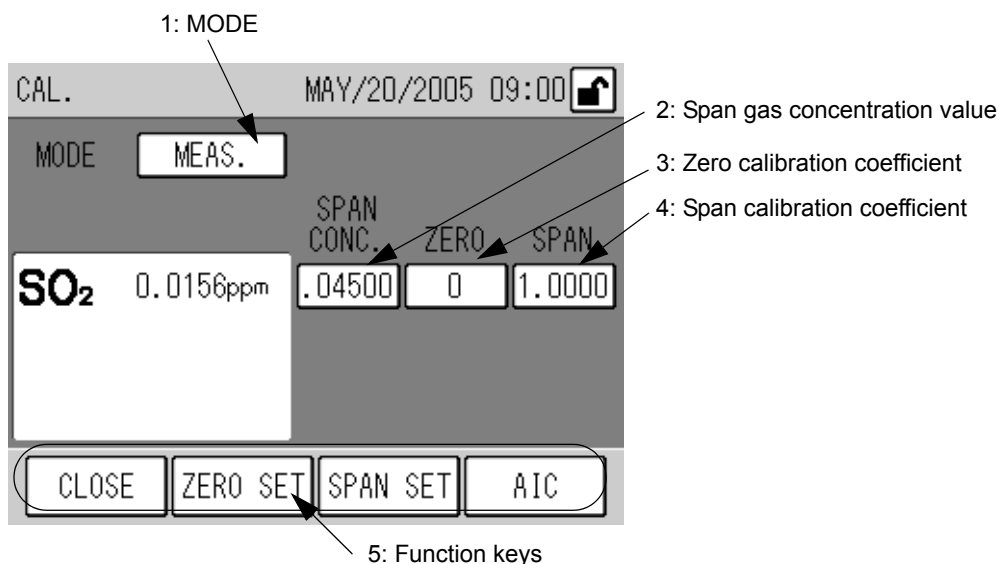

**Fig. 14 CAL. screen**

#### 1: MODE

The selected measurement line is displayed.

Press the displayed MODE setting, and the MODE screen will be displayed (see “ 4.1.2 MODE screen ” (page 12)).

---

## 2: Span gas concentration value

The entered span gas concentration value is displayed.

Different values can be entered for the measured gas and span gas lines.

Press the displayed span gas concentration value, the SPAN CONC. screen will be displayed (see “ 4.1.3 Screens for value setting ” (page 13)).

---

### Note

No span gas concentration value can be entered when the ZERO line is set for MODE.

---

## 3: Zero calibration coefficient

The entered zero calibration coefficient is displayed.

Press the displayed zero calibration coefficient, the ZERO ADJUST screen will be displayed (see “ 4.1.3 Screens for value setting ” (page 13)).

## 4: Span calibration coefficient

The entered span calibration coefficient is displayed.

Press the displayed span calibration coefficient, the SPAN ADJUST screen will be displayed (see “ 4.1.3 Screens for value setting ” (page 13)).

## 5: Function keys

The keys allow you to perform the following operations.

[CLOSE]: Returns to the MEAS. screen (Fig. 5 on page 7).

[ZERO SET]: Displays the zero calibration message (Fig. 36 on page 27).

[SPAN SET]: Displays the span calibration message (Fig. 38 on page 28).

[AIC]: Displays the AIC start message (Fig. 33 on page 25).

Pressing this key during the execution of AIC (the AIC mode icon blinks) displays the AIC abort message (Fig. 34 on page 25).

### 4.1.2 MODE screen

The measurement line can be switched on this screen.

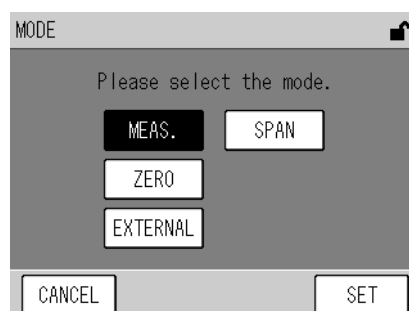

Fig. 15 MODE screen

Press the button for the item to be set.

- MEAS.: To use the MEAS. line, select this button.  
 SPAN: To use the SPAN line, select this button.  
 ZERO: To use the ZERO line, select this button.  
 EXTERNAL: To use the external contact (optional) for line switching, select this button.

The keys allow you to perform the following operations.

- [CANCEL]: Returns to the CAL. screen without changing the settings.  
 [SET]: Returns to the CAL. screen with the settings changed.

### 4.1.3 Screens for value setting

Pressing each display of span gas concentration value, zero calibration coefficient, or span calibration coefficient will display a screen including the numeric keypad that allows you to enter the respective values.

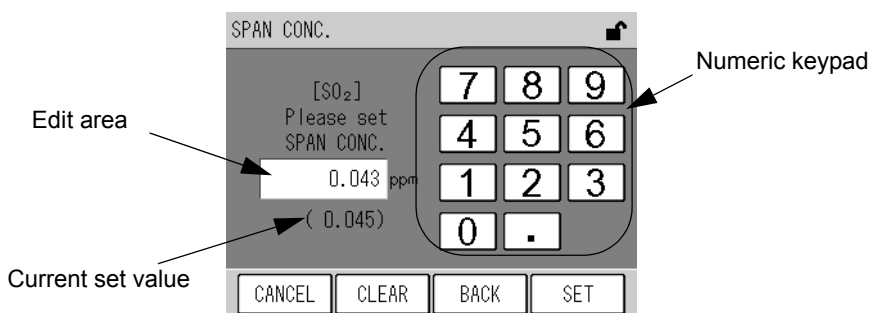

Fig. 16 A screen for value setting (SPAN CONC.)

Item	Settable range	Default setting
Span gas concentration value	.00001 to 99999.	---
Zero calibration coefficient	-3500 to 3500	0
Span calibration coefficient	.50000 to 2.0000	1.0000

Enter a value via the numeric keypad.

The keys allow you to perform the following operations.

- [CANCEL]: Returns to the CAL. screen without changing the settings.  
 [CLEAR]: Deletes the value entered in the edit area  
 [BACK]: Deletes the just entered figure (1-digit).  
 [SET]: Returns to the CAL. screen with the settings changed.

#### Note

If you enter any value that does not meet the settable range, it will be automatically corrected to the nearest value in the settable range.

---

## 4.2 Preparation for Calibration

### 4.2.1 Entering the span gas concentration value

Enter the span gas concentration value to be used for the calibration.

1. Press the displayed **MODE** setting on the **CAL.** screen. The **MODE** screen will be displayed.

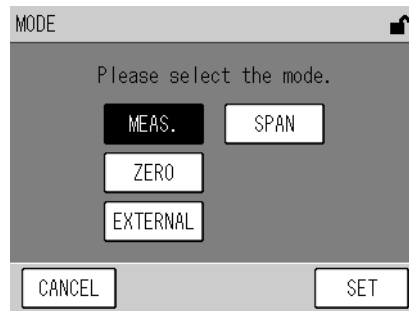

**Fig. 17 MODE screen**

2. Select the measurement line corresponding to the line to be used for the calibration.
  - For manual calibration using the calibration gas line: [SPAN]
  - For manual calibration using the measured gas line: [MEAS.]
  - For auto calibration (AIC): [SPAN]

---

**Tip**

Two different calibration gas concentrations can be set for the [SPAN] and [MEAS.] lines.

---

3. Press the [SET] key to return to the **CAL.** screen.



4. Press the displayed Span Conc. value. The SPAN CONC. screen will be displayed.

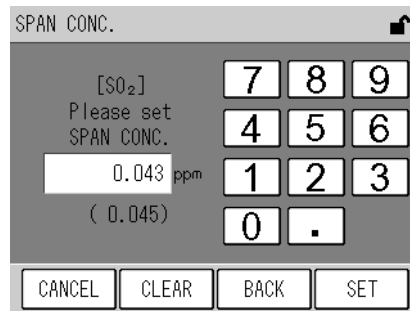

**Fig. 18 SPAN CONC. screen**

item	Settable range
Span Conc. value	.00001 to 99999.

Enter a value via the numeric keypad.

The keys allow you to perform the following operations.

[CANCEL]: Returns to the CAL. screen without changing the settings.

[CLEAR]: Deletes the value entered in the edit area

[BACK]: Deletes the just entered figure (1-digit).

[SET]: Returns to the CAL. screen with the settings changed.

5. Enter a span gas concentration via the numeric keypad.

6. Press the [SET] key to return to the CAL. screen.

### 4.3 Automatic Calibration (AIC)

Automatic calibration (AIC) is started and performed with the internal clock, according to the AIC sequence and conditions set in advance. The AIC sequence can also be started arbitrarily by pressing the [AIC] key on the CAL screen.

#### 4.3.1 AIC setting

1. Press the [MENU] key on the MEAS. screen.
2. Press either the [◀] or [▶] key to display the MENU/SETTING screen.

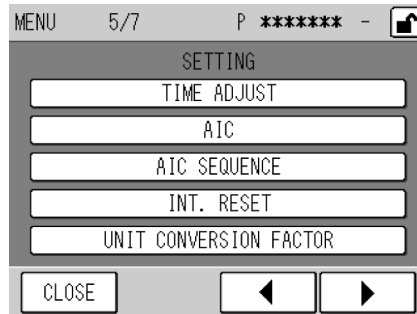

Fig. 19 MENU/SETTING screen

3. Press the [AIC] button. The AIC screen will be displayed.

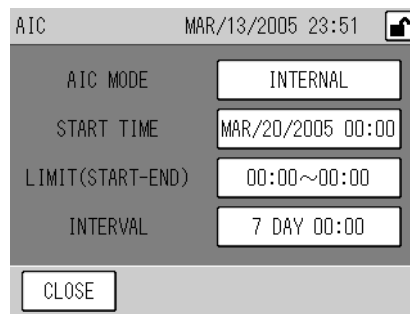

Fig. 20 AIC screen

Item	Description
AIC MODE	Used to specify the method of AIC start. Pressing the displayed AIC MODE setting will display the AIC MODE screen (Fig. 21 on page 17).
START TIME	Used to set the time for starting the next AIC sequence. When the internal clock reaches or exceeds the specified time, the AIC sequence will start. Pressing the displayed START TIME setting will display the START TIME screen (Fig. 22 on page 18).
LIMIT (START-END)	Used to set the range of time available for starting the AIC sequence. Pressing the displayed LIMIT (START-END) setting will display the LIMIT (START-END) screen (Fig. 23 on page 19).
INTERVAL	Used to set the time interval, which applies if the AIC sequence is started periodically. Pressing the displayed INTERVAL setting will display the INTERVAL screen (Fig. 24 on page 20).

**Note**

Only when AIC MODE is set to INTERNAL, the items of START TIME, LIMIT (START-END), and INTERVAL are displayed. These items are not displayed when AIC MODE is set to NONE or EXTERNAL.

4. Press the displayed item to be set. The corresponding setting screen will be displayed.

For the detailed explanation of each screen, see " ● AIC MODE" (page 17) to " ● Automatic correction of start time" (page 21).

5. On the setting screen, change the settings and then press the [SET] key. The changed settings will be saved, and the AIC screen will be displayed again.

**Tip**

To cancel the changes, press the [CANCEL] key. The changes will be undone, and the AIC screen will be displayed again.

6. Press the [CLOSE] key on the AIC screen to return to the MENU screen.

● **AIC MODE**

Specify the method of starting the AIC.

Pressing the displayed AIC MODE setting will display the AIC MODE screen.

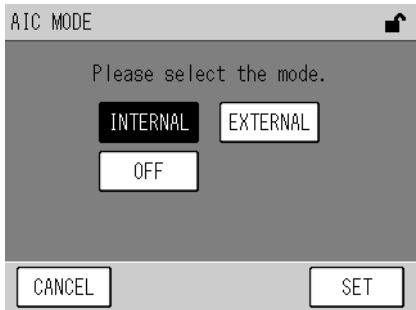

**Fig. 21 AIC MODE screen**

Item	Description
INTERNAL	Selects the mode of using the internal clock to execute AIC at the specified start time and intervals with.
EXTERNAL	Selects the mode of using the external start signal (external contact input) to start AIC. For the telemeter connection specifications, if the telemeter input contact is open (telemeter malfunction), AIC will be started using the internal clock.
OFF	Selects the mode without AIC automatic start.

Press the button of the item to be set.

**Note**

- Manual AIC start and the start via the RS-232C port are valid regardless of this setting.
- If an AIC start signal is inputted externally while an AIC sequence is in progress, this signal will be disregarded and the ongoing AIC sequence will be continued.

Tip

For the telemeter connection specifications, to execute AIC using the internally set START TIME and INTERVAL automatically even if the start signal is not inputted because of telemeter malfunction, set AIC MODE to EXTERNAL.

● **START TIME**

Set the time for starting the next AIC sequence.

Pressing the displayed START TIME setting will display the START TIME screen.

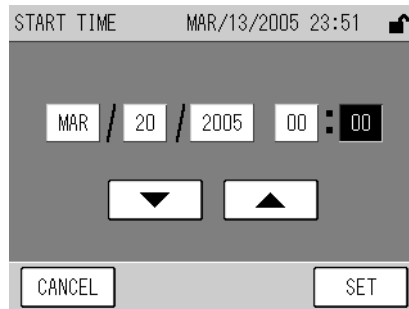

Fig. 22 START TIME screen

Item	Settable range
Year	2000 to 2099
Month	01 to 12
Day	01 to 31
Hour	00 to 23
Minute	00 to 59

Press the value to be changed. The value will be highlighted, allowing you to change it. Using the [▼] and [▲] buttons, change the value.

Note

- The START TIME setting is based on the internal clock.
- The practical range of Year setting is 2000 to 2099.
- The START TIME can not be set to any date that does not practically exist.  
If the [SET] key is pressed with such a value entered, the nearest date and time will be set automatically.
- The START TIME can not be set to any time outside the current LIMIT (START-END) setting.  
If the [SET] key is pressed with such a value entered, the setting is changed automatically so as to be within the range.
- Once the AIC sequence starts, the START TIME setting will be changed to the expected START TIME of the next AIC (the current START TIME + INTERVAL). If the calculated time does not meet the settable ranges of the LIMIT (START-END), it will be corrected automatically (see “ 4.3.2 Precautions in setting the AIC sequence ” (page 21)).
- If the START TIME is set to any time earlier than the current time, the setting will be changed to the minimum later than the current time, which is obtained by adding an integral multiple of the INTERVAL setting to the current START TIME. If the calculated time does not meet the settable ranges of the LIMIT (START-END), it will be corrected automatically.
- If the START TIME becomes earlier than the current time by adjusting the internal clock (see “ 6.5.1 Time adjustment ” (page 56)), the setting will be changed to the minimum later than the current time, which is obtained by adding an integral multiple of the INTERVAL setting to the current START TIME. If the calculated time does not meet the settable ranges of the LIMIT (START-END), it will be corrected automatically.

---

**● LIMIT (START-END)**

Set the range of time available for starting the AIC sequence.

Pressing the displayed LIMIT (START-END) setting will display the LIMIT (START-END) screen.

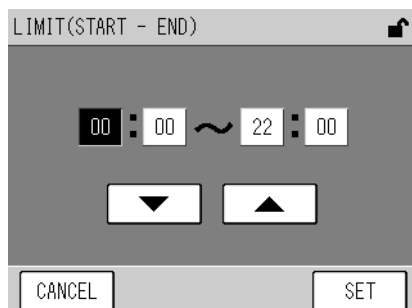

**Fig. 23 LIMIT (START-END) screen**

Item	Settable range
Start: Hour	00 to 23
Start: Minute	00 to 59
End: Hour	00 to 23
End: Minute	00 to 59

Press the value to be changed. The value will be highlighted, allowing you to change it. Using the [▼] and [▲] buttons, change the value.

---

**Note**

- When you do not use the LIMIT (START-END) function, select the default value (00:00 to 00:00).
  - If the START and END values of the range are the same, the LIMIT (START-END) function is invalid.
-

## ● INTERVAL

Set the time interval, which applies if the AIC sequence is started periodically. Pressing the displayed INTERVAL setting will display the INTERVAL screen.

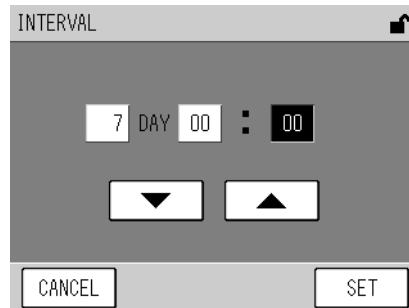

**Fig. 24 INTERVAL screen**

Item	Settable range
Day	0 to 999
Hour	00 to 23
Minute	00 to 59

Press the value to be changed. The value will be highlighted, allowing you to change it. Using the [▼] and [▲] buttons, change the value.

### Note

**INTERVAL should be set to the AIC sequence time plus 10 minutes or longer.**

**If the [SET] key is pressed with a shorter interval entered, the period equivalent to the AIC sequence time plus 10 minutes will be set automatically.**

4.3.2 Precautions in setting the AIC sequence

● Automatic correction of start time

When AIC MODE is set to INTERNAL and an AIC sequence is started, the expected START TIME of the next AIC is calculated using the following equation:

**Expected START TIME of the next AIC (calculated value) = the current START TIME + INTERVAL**

If the calculated time is within the settable range of START TIME, the START TIME setting is changed to the calculated time.

If the calculated time is not within the settable range of START TIME, the START TIME setting is changed to the START time or the END time, whichever is farther from the calculated time, of the closest LIMIT (START-END) to the calculated time.

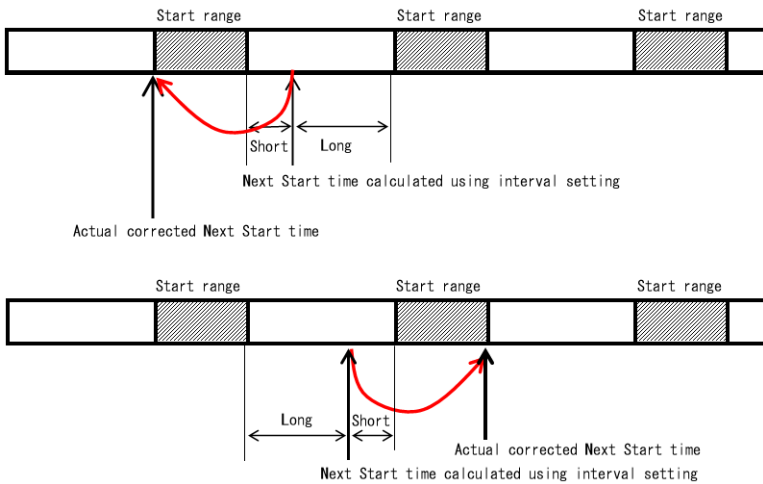

Fig. 25 Automatic correction of START TIME based on the LIMIT (START-END) setting

An example of the automatic correction of start time is given below.  
 If the AIC conditions are as follows:

- START TIME: 20:30
- LIMIT (START-END): 5:00 to 23:00
- INTERVAL: 1 day and 1 hour (25 hours)

START TIME is delayed by one hour every day. As days pass, START TIME eventually runs out of the LIMIT (START-END) setting.

In this example, since the calculated value of the fourth START TIME (23:30) is not within the LIMIT (START-END) setting, the fourth START TIME is changed to the START time (5:00) of the LIMIT (START-END) just before the calculated time.

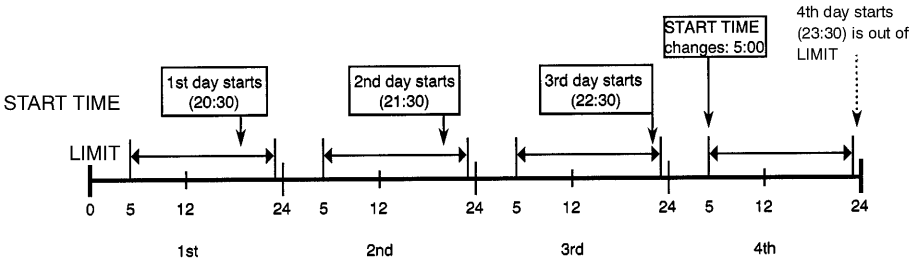

Fig. 26 An example of automatic correction of START TIME

### 4.3.3 Setting the AIC sequence

To set the AIC sequence, go to the AIC SEQUENCE screen.

1. Press the [MENU] key on the MEAS. screen.
2. Press the [◀] or [▶] key to display the MENU/SETTING screen.

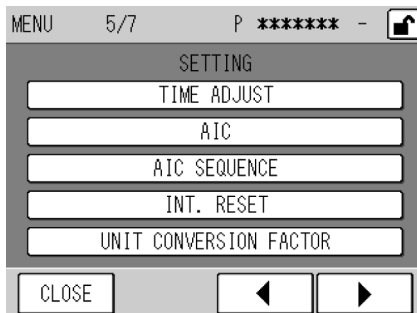

Fig. 27 MENU/SETTING screen

3. Press the [AIC SEQUENCE] button. The AIC SEQUENCE screen will be displayed.

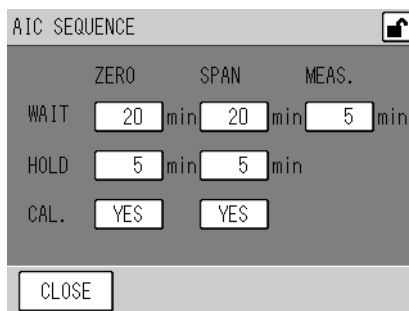

Fig. 28 AIC SEQUENCE screen

Item	Settable range	Description
WAIT	0 min to 999 min	Set the waiting time for stabilization after changing gas. The recommended setting is 20 minutes or longer.
HOLD	0 min to 999 min	Set the calibration validation time (to check the readouts on the recorder after finishing the calibration).
CAL.	YES/NO	Specify whether or not to perform calibration. YES: Calibration is performed. NO: Calibration is not performed.



**4. Press the displayed setting to be changed. The corresponding setting screen will be displayed.**

- WAIT or HOLD

The following screen for time setting will appear.

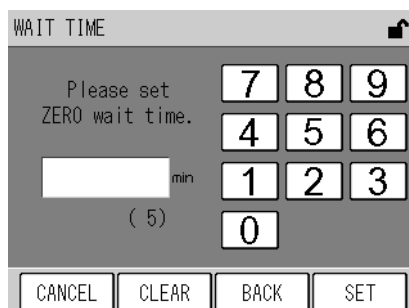

**Fig. 29 A screen for time setting (WAIT TIME)**

- CAL.

The following CAL. screen for setting will appear.

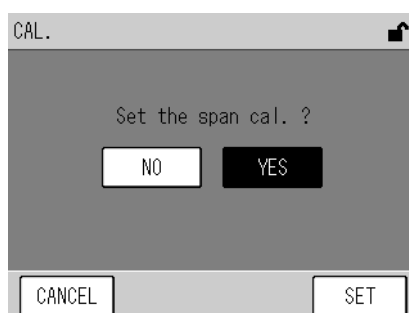

**Fig. 30 CAL. screen (for SPAN)**

**5. Change the setting by entering time on the time setting screen or pressing either [YES] or [NO] button on the CAL. screen, and then press the [SET] key.**

The setting will be changed and the AIC SEQUENCE screen will be displayed again.

**Note**

- Any process for which time is set to 0 min is skipped and the AIC sequence proceeds to the next step. For example, if WAIT for SPAN is set to 0 min, no span gas will be supplied.
- If CAL. is set to NO, calibration is not performed in the AIC sequence.
- If the total time of the AIC sequence exceeds the value of AIC INTERVAL minus 10 min, the AIC INTERVAL setting will be automatically changed to the value of the total time of the AIC sequence plus 10 min.

**6. Press the [CLOSE] button on the AIC SEQUENCE screen.**

The MENU screen is displayed again.

An example of the AIC sequence is shown in the following diagram:

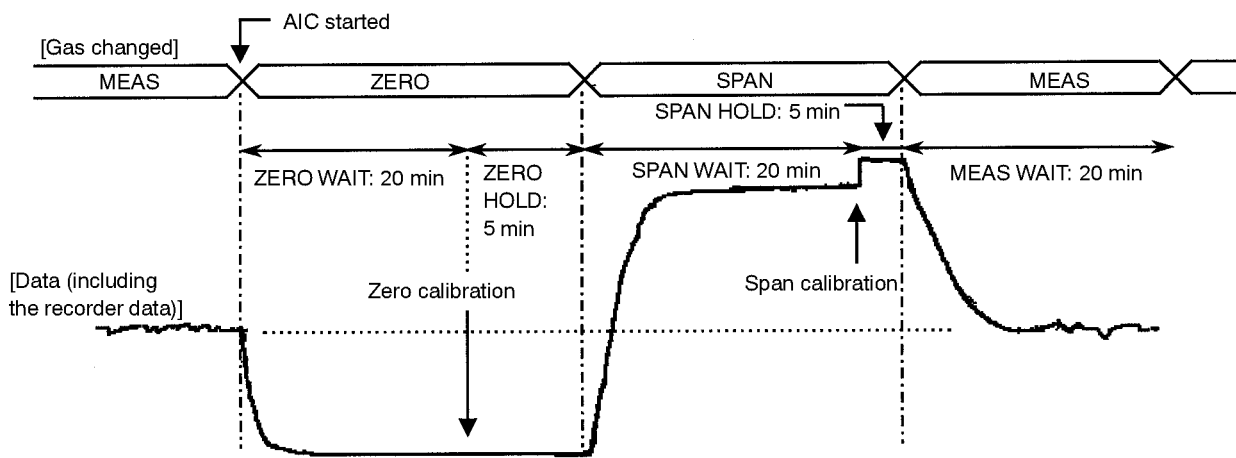

Fig. 31 An example of the AIC sequence

### 4.3.4 Starting the AIC sequence with the [AIC] key

1. Press the [CAL.] key on the MEAS. screen. The CAL. screen will be displayed.

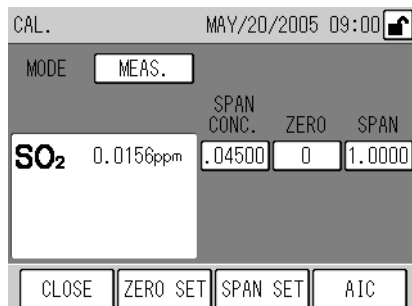

Fig. 32 CAL. screen

2. Press the [AIC] key. The AIC start message will appear.

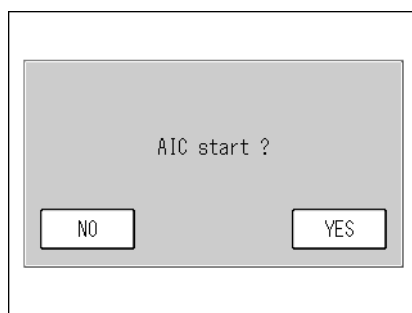

Fig. 33 AIC start message

3. Press the [YES] button. The preset AIC sequence will start.

While the AIC sequence is in progress, the CAL. screen is displayed again and the AIC mode icon blinks. Pressing the [AIC] key in this state displays the AIC abort message.

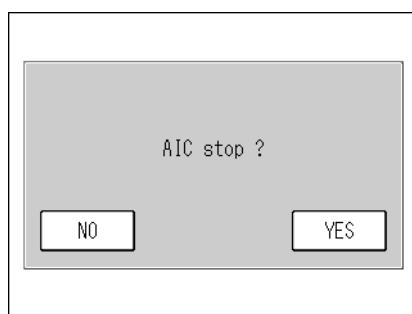

Fig. 34 AIC abort message

The keys allow you to perform the following operations.

- [YES]: The ongoing AIC sequence will be aborted.
- [NO]: The ongoing AIC sequence will be continued.

#### Note

For the AIC sequence and its setting, see page 16 to page 24.

## 4.4 Manual Calibration

After preparing for the calibration (see “ 4.2 Preparation for Calibration ” (page 14)), perform the zero calibration and the span calibration in this order.

### 4.4.1 Operational flow

The operational flow for manual calibration is described below:

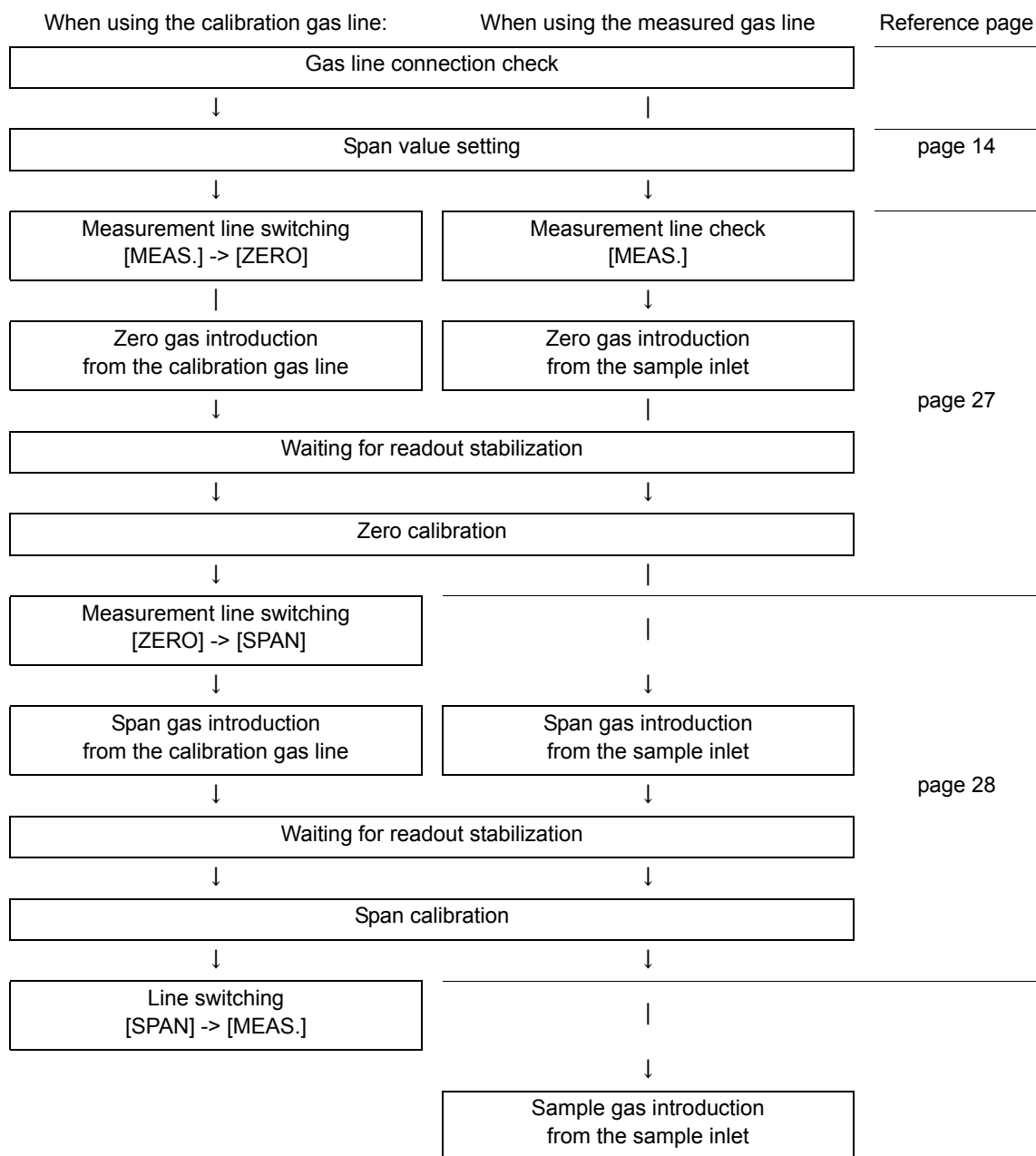

**Note**

Control the zero gas and span gas feed pressures at atmospheric pressure plus (0 kPa to 0.5 kPa).

#### 4.4.2 Zero calibration

1. On the CAL. screen, check that the proper measurement line is selected.

If necessary, press the displayed MODE setting on the CAL. screen to display the MODE screen, and then change the setting and press the [SET] key on the MODE screen.

When using the calibration gas line: Select [ZERO].

When using the measured gas line: Select [MEAS.].

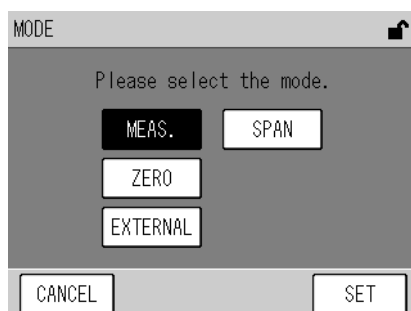

Fig. 35 MODE screen

2. When using the measured gas line, supply the zero gas from the sample gas inlet.
3. Wait for the readouts to be stabilized and then press the [ZERO] key on the CAL. screen. The zero calibration message will appear.

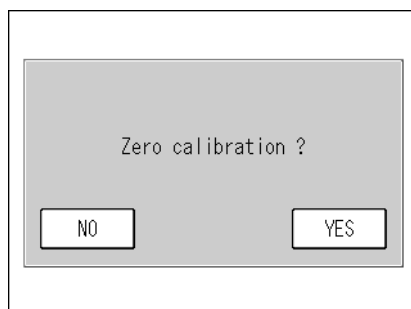

Fig. 36 Zero calibration message

#### Note

The [ZERO SET] key on the CAL. screen is valid only when MODE is set to MEAS. or ZERO.

4. Press the [YES] button. The zero calibration will be started. After the calibration is completed, the zero calibration coefficient will be updated and the CAL. screen will be displayed again.

#### Tip

To return the CAL. screen without executing zero calibration, press the [NO] button of the zero calibration message.

#### Note

If the result of the zero calibration deviates from the allowable range of zero calibration ( $\pm 3500$  counts), the ZERO (zero calibration) alarm occurs (see " 8.2 Alarm List " (page 82)) and the zero calibration coefficient is not updated. In this case, the zero calibration coefficient displayed on the CAL. screen blinks. And if the standard output terminal block is provided, the alarm contact signal is outputted. See the rear panel signal table at the end of this document.

### 4.4.3 Span calibration

1. On the CAL. screen, check that the proper measurement line is selected.  
If necessary, press the displayed MODE setting on the CAL. screen to display the MODE screen, and then change the setting and press the [SET] key on the MODE screen.  
When using the calibration gas line: Select [SPAN].  
When using the measured gas line: Select [MEAS.].

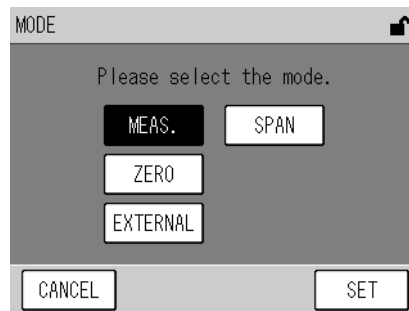

Fig. 37 MODE screen

2. When using the measured gas line, supply the span gas from the sample gas inlet.
3. Wait for the readouts to be stabilized and then press the [SPAN] key on the CAL. screen. The span calibration message will appear.

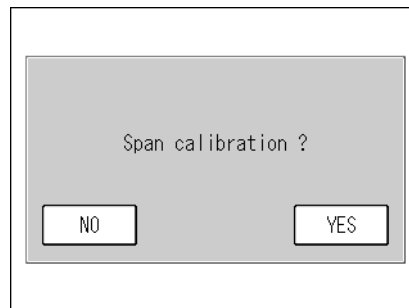

Fig. 38 Span calibration message

#### Note

The [SPAN SET] key on the CAL. screen is valid only when MODE is set to MEAS. or SPAN.

4. Press the [YES] button. The span calibration will be started. After the calibration is completed, the span calibration coefficient will be updated and the CAL. screen will be displayed again.

#### Tip

To return the CAL. screen without executing span calibration, press the [NO] button of the span calibration message.

#### Note

If the result of the span calibration deviates from the allowable range of span calibration (0.5 to 2.0), the SPAN (span calibration) alarm occurs (see “ 8.2 Alarm List ” (page 82)) and the span calibration coefficient is not updated. In this case, the span calibration coefficient displayed on the CAL. screen blinks. And if the standard output terminal block is provided, the alarm contact signal is outputted. See the rear panel signal table at the end of this document.

---

#### 4.4.4 Finishing calibration

1. When using the calibration gas line, display the MODE screen and change the measurement line to [MEAS.].  
When using the measured gas line, supply the sample gas to the measured gas line.
2. Press the [CLOSE] key on the CAL. screen. The MEAS. screen will be displayed again and the measurement will start.

## 5 DATA PROCESSING

Based on the acquired data, average, integration, and rolling average values are calculated. These values can be checked on the screen.

To check the data, press the [MENU] key on the MEAS. screen to display the MENU/DATA screen and then press the button of the data to be displayed.

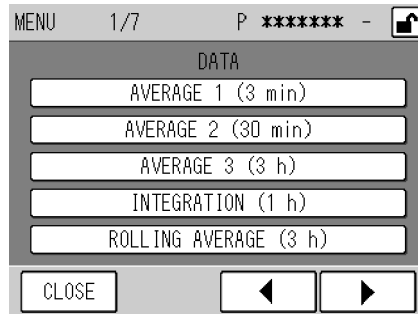

**Fig. 39 MENU/DATA screen**

The buttons allow you to perform the following operations.

[AVERAGE 1] to [AVERAGE 3]:

Displays the corresponding AVERAGE screen (see “ 5.1 Average ” (page 33)).

[INTEGRATION]: Displays the INTEGRATION screen (see “ 5.2 Integration ” (page 35)).

[ROLLING AVERAGE]:

Displays the ROLLING AVERAGE screen (see “ 5.3 Rolling Average ” (page 37)).



### ● Screens for data check

The common functionalities of the screens for data check are described below:

On the MENU/DATA screen, press the button of the data to be displayed. The following screen for data check will be displayed.

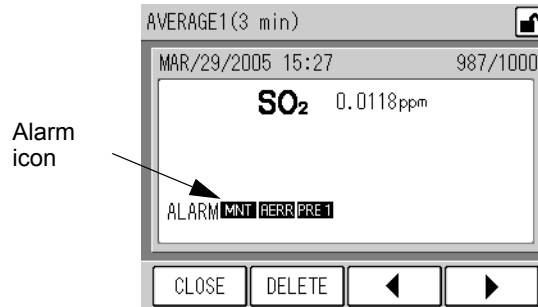

**Fig. 40 AVERAGE screen (AVERAGE 1)**

Immediately after this screen is opened, the latest calculation results are displayed.

The keys allow you to perform the following operations.

[CLOSE]: Returns to the MENU/DATA screen.

[DELETE]: Displays the message confirming data deletion (Fig. 42 on page 32).  
This button is hidden when the keys are locked.

[◀]: Displays the previous page.  
When the page of the oldest records is displayed, pressing this key displays the page of the latest records.

[▶]: Displays the next page.  
When the page of the latest records is displayed, pressing this key displays the page of the oldest records.

#### Note

- If the displayed data was acquired when an alarm occurred, the alarm icon is displayed. For the details of the alarm icon, see "● Alarm icon: Checking the data alarm status" (page 81).
- If no data is recorded, the following message appears:

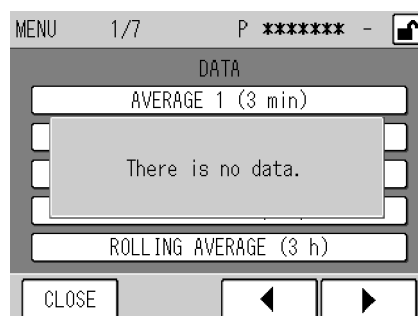

**Fig. 41 Message when no data is recorded**

---

**● Deleting data**

All the records of the calculated average and integration data can be deleted at a time. As for the rolling average data, the currently calculated one can be deleted.

1. Check that the keys are unlocked (Fig. 10 on page 8).  
If the keys are locked, unlock them (see “ 6.8 Key Lock ” (page 75)).
2. Display the data to be deleted on the screen for data check, and press the [DELETE] key. The message confirming data deletion will appear.

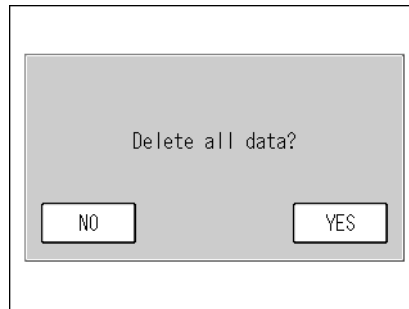

**Fig. 42 Message confirming data deletion**

3. Press the [YES] button. The message of deleting data will be displayed and the data deletion will start. After the data deletion is completed, the screen for data check will be displayed again.

---

**Note**

To return the screen for data check without deleting the data, press the [NO] button.

---



**Fig. 43 Message of deleting data**

## 5.1 Average

An average data is calculated by summing the measured values (momentary values) acquired every 1 second for a specified calculation period, and then dividing the cumulative total by the data counts.

There are three AVERAGE data (AVERAGE 1 to AVERAGE 3), calculated using different calculation periods. And these calculation results can be checked on the respective AVERAGE screens.

**Table 1 AVERAGE types**

Data	Calculation period	Recorded data capacity
AVERAGE 1	3 min	1000 data
AVERAGE 2	30 min	1000 data
AVERAGE 3	3 h	100 data

### Note

- If the data counts exceeds the data capacity, the oldest data will be automatically deleted.
- The time displayed on the AVERAGE screen is the final data acquisition time.

Pressing the [AVERAGE 1], [AVERAGE 2], or [AVERAGE 3] on the MENU/DATA screen displays the screen showing the latest data.

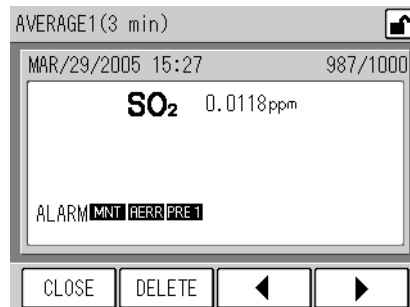

**Fig. 44 AVERAGE screen (AVERAGE 1)**

If an alarm occurs within the calculation period, the alarm record is also displayed with the data.

### Note

- For the details of alarms, see " 8.2 Alarm List " (page 82).
- A maximum of 16 alarms can be displayed in high-priority order.  
If the 17th or later alarms occur within the same calculation period, these alarms are not displayed.

For the other screen functionalities, see " ● Screens for data check" (page 31).

● **Average calculation**

The timing of average calculation start or end is based on the internal clock.

**If power shutdown occurs or if the internal clock is put forward:**

The momentary data during the power shutdown or the put-forwarded time period will be regarded as missing.

If all the momentary values during the calculation period are missing, no average data will be recorded.

If power shutdown occurs before the data is saved or while the average, integration, or rolling average data is displayed, no data will be recorded.

**If the internal clock is put back:**

The subsequent operation depends upon the corrected time.

If the corrected time is the same as or later than the start time of the ongoing integration calculation, the integration calculation will go on.

If the corrected time is earlier than the start time of the ongoing integration calculation, the integration results up to now will be discarded and new integration calculation will start.

**If the data that now being saved and an existing data have the same creation time:**

The existing data will be overwritten with the new one (the existing data will be deleted).

## 5.2 Integration

An integration data is calculated by dividing the measured values (momentary values) acquired every 1 second by 3600 and summing these data for a specified calculation period.

This calculation result can be checked on the INTEGRATION screen.

The calculation period is 1 hour, and the data capacity is 1000 data.

### Note

- If the data counts exceeds the data capacity, the oldest data will be automatically deleted.
- The time displayed on the INTEGRATION screen is the final data acquisition time.

Pressing the [INTEGRATION] on the MENU/DATA screen displays the screen showing the latest data.

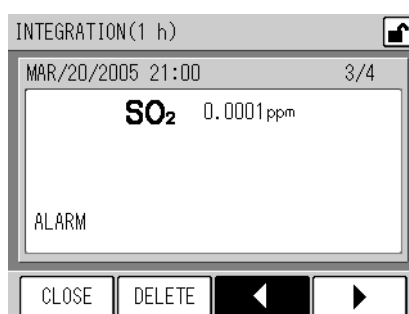

Fig. 45 INTEGRATION screen

If an alarm occurs within the calculation period, the alarm record is also displayed with the data.

### Note

- For the details of alarms, see “ 8.2 Alarm List ” (page 82).
- A maximum of 16 alarms can be displayed in high-priority order.  
If the 17th or later alarms occur within the same calculation period, these alarms are not displayed.

For the other screen functionalities, see “ ● Screens for data check ” (page 31).

### ● Integration calculation

In the case of the standard specification, the timing of the integration calculation start and end is controlled by sending the ON signal to the integration value reset input (RST input) on the signal connection terminal block (see “ 6.5.4 Integration reset setting ” (page 57)), or by receiving the integration calculation reset command via serial communication (refer to the instruction manual of APXX-370 Series RS-232C).

These signal input and command reception are called external integration reset.

Once external integration reset is performed, the following action will occur automatically.

The internal clock time will be adjusted to the integration reset time nearest to the current time.

(For the standard specification, the default integration reset time is 00 min every hour. It can be set to 30 min every hour.)

If the adjusted time is the same as the expected reset time of the ongoing integration, the integration result will be recorded at that time and then the integration value output will be reset to zero (integration reset).

**If the external integration reset is not performed after the time of the ongoing integration end + the waiting time for integration reset (3 min for the standard specification, 6 min for special specification) :**

The integration result will be recorded at that time and then the integration value output will be reset to zero (integration reset). The internal clock will not be adjusted.

**If the internal clock is put back:**

The subsequent operation depends upon the corrected time.

If the corrected time is the same as or later than the start time of the ongoing integration calculation, the integration calculation will go on.

If the corrected time is earlier than the start time of the ongoing integration calculation, the integration results up to now will be discarded and new integration calculation will start.

**If the data that now being saved and an existing data have the same creation time:**

The existing data will be overwritten with the new one (the existing data will be deleted).

**If an existing data has the creation time later than that of the data now being saved:**

The data having the later creation time will be deleted.

## 5.3 Rolling Average

The rolling average value between the current time and the 3-hour earlier point is sequentially displayed on the ROLLING AVERAGE screen as time passes.

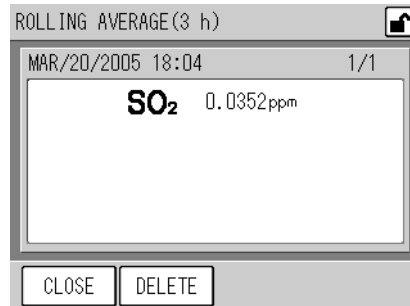

**Fig. 46 ROLLING AVERAGE screen**

For the screen functionalities, see "● Screens for data check" (page 31).

### ● Rolling average calculation

The momentary value at that point is used for this calculation.

#### **If power shutdown occurs:**

The momentary values during the shutdown period will be regarded as missing.

## 6 FUNCTIONALITIES

The MEAS. screen allows you to use the following functionalities:

**By starting with the [MENU] key:**

- Displaying average, integration, and rolling average values (see page 30)
- Displaying history (see page 40)
- Checking/adjusting analog output (see page 44)
- Checking analog input (see page 48)
- Checking/setting the hour meter (see page 49)
- Displaying lamp history (see page 50)
- Setting the analog output range (see page 52)
- Setting the current time (see page 56)
- Setting the AIC (see page 16)
- Setting the AIC sequence (see page 22)
- Selecting the integration reset (see page 57)
- Specifying a unit conversion factor (see page 58)
- Setting the LCD (see page 60)
- Touch panel adjustment (see page 62)
- Specifying a password (see page 63)
- Writing to the memory (see page 65)
- Setting the machine ID (see page 67)
- Setting TCP/IP (optional, see page 70)

**By starting with the [KEY LOCK] button:**

- Locking/unlocking the keys (see page 75)



## ● MENU screens

Pressing the [MENU] key on the MEAS. screen allows you to use functionalities such as data review and settings.

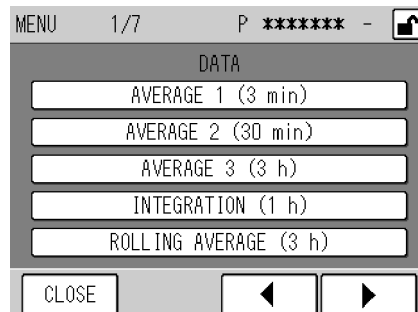

**Fig. 47 MENU screen (DATA)**

The following seven different MENU screens are available:

- DATA (Fig. 39 on page 30)
- HISTORY (Fig. 48 on page 40)
- MAINTENANCE (Fig. 55 on page 44)
- RANGE (Fig. 65 on page 52)
- SETTING (Fig. 70 on page 55)
- SYSTEM (Fig. 75 on page 60)
- COMMUNICATION (Fig. 85 on page 66)

The MENU/DATA screen always appears first.

The keys allow you to perform the following operations (common to all MENU screens).

- [CLOSE]: Returns to the MEAS. screen.
- [◀]: Displays the previous page.
- [▶]: Displays the next page.

## 6.1 Data Menu

The DATA menu allows you to display average, integration, and rolling average data. For further information on the MENU/DATA screen, see “ 5 DATA PROCESSING ” (page 30).

## 6.2 History Menu

The HISTORY menu is used to display the calibration history and alarm history.

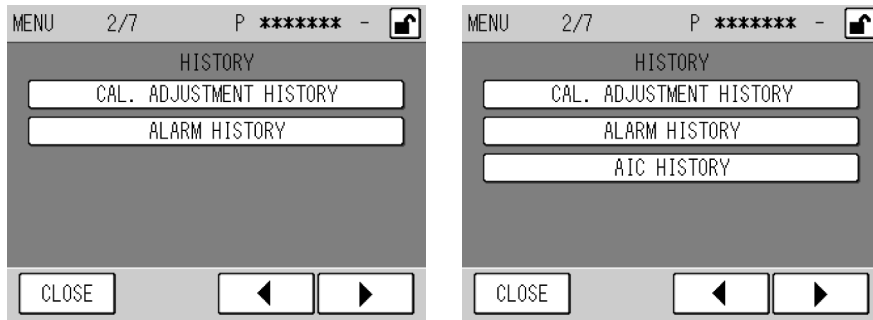

**Fig. 48 MENU/HISTORY screen**

The buttons allow you to perform the following operations.

[CAL. ADJUSTMENT HISTORY]:

Displays the CAL. ADJUSTMENT HISTORY screen (Fig. 52 on page 42).

[ALARM HISTORY]:

Displays the ALARM HISTORY screen (Fig. 53 on page 42).

[AIC HISTORY] (optional):

Displays the AIC HISTORY screen (Fig. 54 on page 43 ).

### ● Operation of the HISTORY screens

The common functionalities to the HISTORY screens are described below:

On the MENU/HISTORY screen, press the button for the history to be displayed. The following HISTORY screen will be displayed.

DATE/TIME	COMP.	CAL.	VALUE
APR/23/2005 09:00	SO <sub>2</sub>	SPAN	0.9844
APR/23/2005 09:00	SO <sub>2</sub>	ZERO	287
APR/05/2005 09:00	SO <sub>2</sub>	SPAN	1.0116
APR/05/2005 09:00	SO <sub>2</sub>	ZERO	232
MAR/27/2005 09:00	SO <sub>2</sub>	SPAN	0.9935
MAR/27/2005 09:00	SO <sub>2</sub>	ZERO	92
MAR/20/2005 09:00	SO <sub>2</sub>	SPAN	0.9989

**Fig. 49 HISTORY screen (CAL. ADJUSTMENT)**

The latest history is always displayed first.

---

The keys allow you to perform the following operations.

- [CLOSE]: Returns to the MENU/HISTORY screen.  
[DELETE]: Displays the message confirming data deletion (Fig. 50 on page 41).  
[◀]: Displays the previous page.  
[▶]: Displays the next page.

---

**Note**

- The [DELETE] key is hidden when the keys are locked.
  - The [◀] and [▶] keys are hidden when the data is within one page (up to 7 data).
- 

### Deleting history

All the recorded histories may be deleted at a time.

1. Press the [DELETE] key on the HISTORY screen including the histories to be deleted. A message will appear confirming the data deletion.

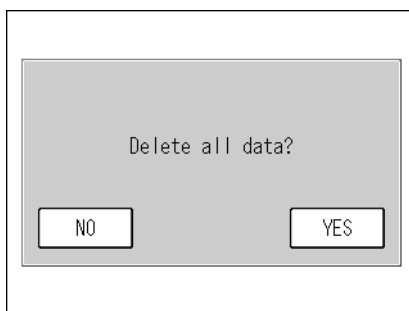

Fig. 50 Message confirming data deletion

2. Press the [YES] button. The message of deleting data will be displayed and the data deletion will start. After the data deletion is completed, the HISTORY screen will be displayed again.

---

**Note**

To return the HISTORY screen without deleting data, press the [NO] button.

---



Fig. 51 Message of deleting data

### 6.2.1 Calibration history

Press the [CAL. ADJUSTMENT HISTORY] button on the MENU/HISTORY screen. The latest calibration history will be displayed.

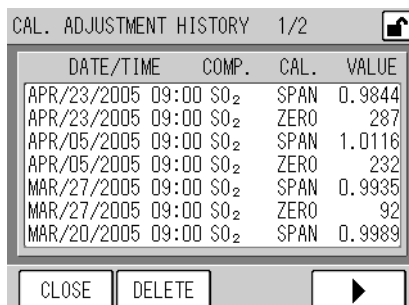

CAL. ADJUSTMENT HISTORY 1/2

DATE/TIME	COMP.	CAL.	VALUE
APR/23/2005 09:00	SO <sub>2</sub>	SPAN	0.9844
APR/23/2005 09:00	SO <sub>2</sub>	ZERO	287
APR/05/2005 09:00	SO <sub>2</sub>	SPAN	1.0116
APR/05/2005 09:00	SO <sub>2</sub>	ZERO	232
MAR/27/2005 09:00	SO <sub>2</sub>	SPAN	0.9935
MAR/27/2005 09:00	SO <sub>2</sub>	ZERO	92
MAR/20/2005 09:00	SO <sub>2</sub>	SPAN	0.9989

CLOSE DELETE

Fig. 52 CAL. ADJUSTMENT HISTORY screen

For the screen functionalities, see " ● Operation of the HISTORY screens" (page 40).

### 6.2.2 Alarm history

Press the [ALARM HISTORY] button on the MENU/HISTORY screen. The latest alarm history will be displayed.

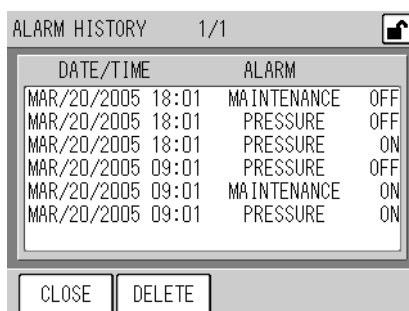

ALARM HISTORY 1/1

DATE/TIME	ALARM	
MAR/20/2005 18:01	MAINTENANCE	OFF
MAR/20/2005 18:01	PRESSURE	OFF
MAR/20/2005 18:01	PRESSURE	ON
MAR/20/2005 09:01	PRESSURE	OFF
MAR/20/2005 09:01	MAINTENANCE	ON
MAR/20/2005 09:01	PRESSURE	ON

CLOSE DELETE

Fig. 53 ALARM HISTORY screen

For the screen functionalities, see " ● Operation of the HISTORY screens" (page 40).

### 6.2.3 AIC history (optional)

Press the [AIC HISTORY] button on the MENU/HISTORY screen. The latest AIC history will be displayed.

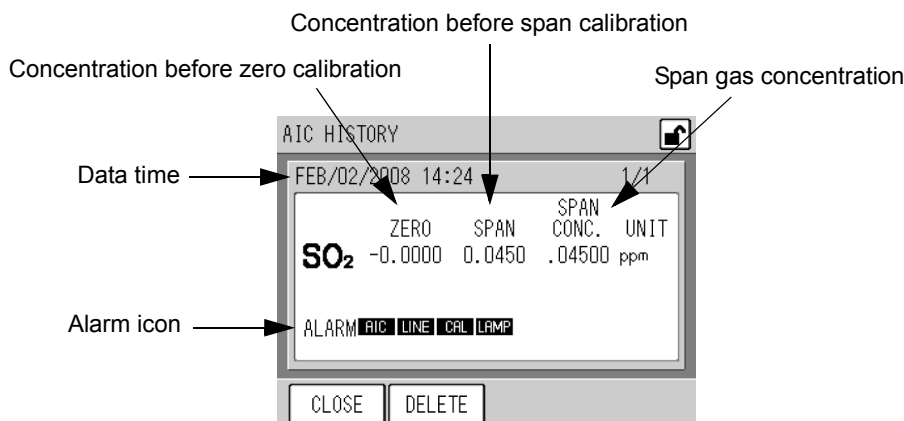

**Fig. 54 AIC HISTORY screen**

For each measurement component, the concentration value before zero calibration, the concentration value before span calibration, the span gas concentration value, and unit are displayed. The concentration before zero calibration is the concentration value of zero gas at the end of WAIT time set in the AIC SEQUENCE screen. The concentration before span calibration is the concentration value of span gas at the end of WAIT time set in the AIC SEQUENCE screen. If the flow time of zero gas or span gas is shorter than WAIT time, "----" is displayed. The span gas concentration is the concentration value used in span calibration during the AIC sequence.

If an alarm occurs within the AIC sequence period, the alarm record is also displayed with the history data.

Data time differs depending on the status of AIC sequence. Refer to "Table 2 Data time."

**Table 2 Data time**

AIC sequence	AIC SEQUENCE screen		Time added to data
	WAIT time for zero gas	WAIT time for span gas	
Normally completed	more than 1 min	more than 1 min	Time when WAIT time for span gas is finished
	0 min	more than 1 min	Time when WAIT time for span gas is finished
	more than 1 min	0 min	Time when WAIT time for zero gas is finished
Canceled	-	-	Time when the AIC sequence is canceled

For the screen functionalities, see "● Operation of the HISTORY screens" (page 40).

#### Note

- For the details of alarms, see "8.2 Alarm List" (page 82).
- A maximum of 16 alarms can be displayed in high-priority order. If the 17th or later alarms occur within the same calculation period, these alarms are not displayed.

## 6.3 Maintenance Menu

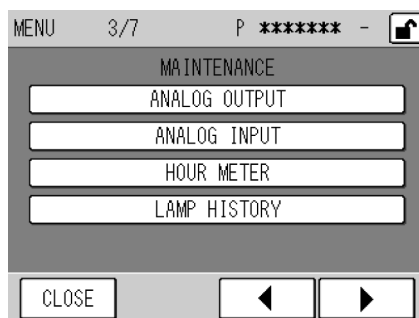

**Fig. 55 MENU/MAINTENANCE screen**

The keys allow you to perform the following operations.

[ANALOG OUTPUT]:	Displays the ANALOG OUTPUT screen (Fig. 56 on page 44).
[ANALOG INPUT]:	Displays the ANALOG INPUT screen (Fig. 59 on page 48).
[HOUR METER]:	Displays the HOUR METER screen (Fig. 60 on page 49).
[LAMP HISTORY]:	Displays the LAMP HISTORY screen (Fig. 62 on page 50)

### 6.3.1 Analog output

Press the [ANALOG OUTPUT] button on the MENU/MAINTENANCE screen. The ANALOG OUTPUT screen will be displayed.

This screen allows you to check and control the analog output.

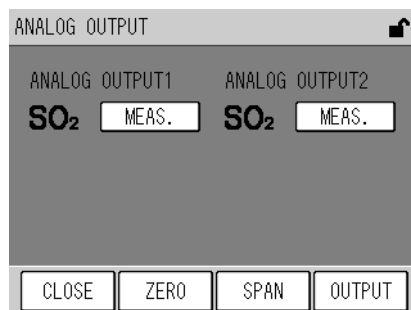

**Fig. 56 ANALOG OUTPUT screen**

The current output modes of ANALOG OUTPUT 1 (momentary value) and ANALOG OUTPUT 2 (which varies depending on the specification; integration value for the standard specification) are displayed as buttons.

[MEAS.]:	The current measured value is being outputted. This is normal mode.
[XX%]:	XX% of the full scale is being outputted. The settable value is between 0% (example: about 0 V) and 100% (example: about 1 V) in steps of 10%.

#### Note

All outputs are always in the [MEAS.] mode (the current measured value is being outputted) first.

The buttons allow you to select and check the output modes (see below).

The keys allow you to perform the following operations.

- [CLOSE]: Returns to the MENU/MAINTENANCE screen.  
 [ZERO]: Displays the DA ADJUST/ ZERO screen for zero calibration of analog output (Fig. 57 on page 46).  
 [SPAN]: Displays the DA ADJUST/ SPAN screen for span calibration of analog output (Fig. 58 on page 47).  
 [OUTPUT]: Outputs the selected output via the analog output terminal.

## ● Checking output

1. On the **ANALOG OUTPUT** screen, press the button of the output mode to be changed.

With every pressing of the button, the button display and the actual output mode are automatically changed in the following order:

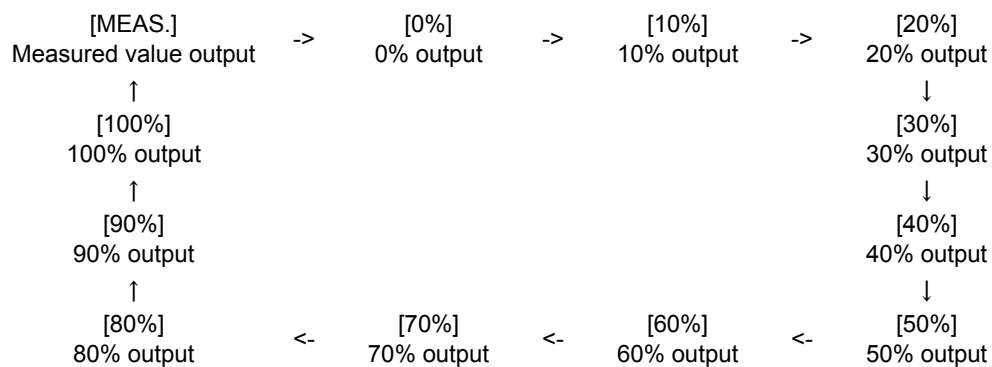

2. To finish output check, press the [CLOSE] key to return to the MENU/MAINTENANCE screen.

### Note

Pressing the [CLOSE] key will put all the output back to the measured values.

● **Adjusting the zero output and span output**

**Zero output adjustment**

1. Output [0%] on the ANALOG OUTPUT screen and then press the [ZERO] key. The DA ADJUST/ ZERO screen will be displayed.

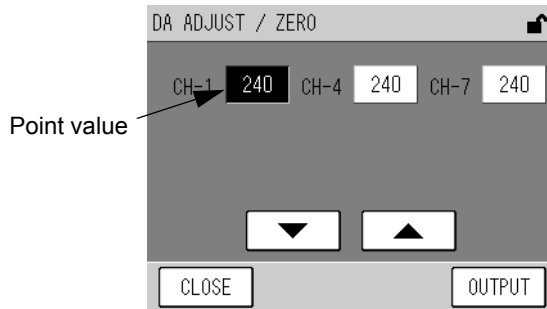

**Fig. 57 DA ADJUST/ ZERO screen**

The respective output point values of the channels are displayed.

The outputs allocated to the channels are as follows:

CH	Analog output	Terminal
CH-1	Non-insulated output of momentary value (0 V to 1 V) (ANALOG OUTPUT 1)	C1 — C4
CH-4	Insulated output of momentary value (0 V to 1 V) (ANALOG OUTPUT 2)	A8 — A9
CH-7	Non-insulated output of rolling average value (0 V to 1 V) (ANALOG OUTPUT 2)	C5 — C8

---

**Tip**  
**For the terminal block output, see the rear panel signal table at the end of this document.**

---

Press a point value button, and the button will be highlighted.

In this state, the following buttons allow you to perform the following operations.

- [▲]: Increases the point value for the selected channel. A 10-point increment increases the output about 3 mV.
- [▼]: Decreases the point value for the selected channel. A 10-point decrement decreases the output about 3 mV.

The keys allow you to perform the following operations.

- [CLOSE]: Returns to the ANALOG OUTPUT screen.
- [OUTPUT]: Establishes each point value.

2. Press the point value button for the channel to be adjusted. The selected point value will be highlighted.
3. Change the point value by pressing the [▲] or [▼] button.
4. To establish all the point values, press the [OUTPUT] key.
5. Press the [CLOSE] key to return to the ANALOG OUTPUT screen (Fig. 56 on page 44).
6. Check the output (page 45). If necessary, repeat the above steps to make readjustment.



### Span output adjustment

1. Output [100%] on the ANALOG OUTPUT screen and then press the [SPAN] key. The DA ADJUST/ SPAN screen will be displayed.

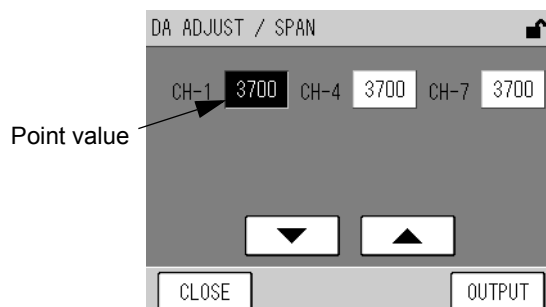

**Fig. 58 DA ADJUST/ SPAN screen**

The respective output point values of the channels are displayed.  
The outputs allocated to the channels are as follows:

CH	Analog output	Terminal
CH-1	Non-insulated output of momentary value (0 V to 1 V) (ANALOG OUTPUT 1)	C1 — C4
CH-4	Insulated output of momentary value (0 V to 1 V) (ANALOG OUTPUT 2)	A8 — A9
CH-7	Non-insulated output of rolling average value (0 V to 1 V) (ANALOG OUTPUT 2)	C5 — C8

#### Tip

For the terminal block output, see the rear panel signal table at the end of this document.

Press a point value button, and the button will be highlighted.

In this state, the following buttons allow you to perform the following operations.

- [▲]: Increases the point value for the selected channel. A 10-point increment increases the output about 3 mV.
- [▼]: Decreases the point value for the selected channel. A 10-point decrement decreases the output about 3 mV.

The keys allow you to perform the following operations.

- [CLOSE]: Returns to the ANALOG OUTPUT screen.
- [OUTPUT]: Establishes each point value.

2. Press the point value button for the channel to be adjusted. The selected point value will be highlighted.
3. Change the point value by pressing the [▲] or [▼] button.
4. To establish all the point values, press the [OUTPUT] key.
5. Press the [CLOSE] key to return to the ANALOG OUTPUT screen (Fig. 56 on page 44).
6. Check the output (page 45). If necessary, repeat the above steps to make readjustment.

### 6.3.2 Analog input

Press the [ANALOG INPUT] button on the MENU/MAINTENANCE screen. The ANALOG INPUT screen will be displayed.

This screen, which shows the analog input values, is used to check the statuses of analog signals inputted from the sensor and others.

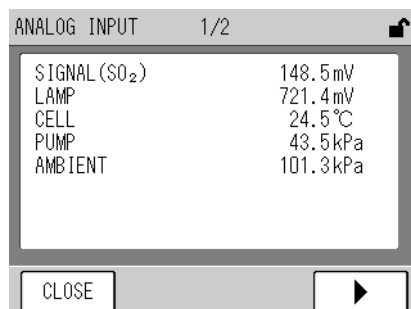

**Fig. 59 ANALOG INPUT screen**

The analog input values are listed across 2 pages.

The keys allow you to perform the following operations.

[CLOSE]: Returns to the MENU/MAINTENANCE screen.

[◀]: Displays the previous page.

[▶]: Displays the next page.

The displayed items and its units are shown below:

Signal name	Unit	Description
SIGNAL	mV	Voltage of the measured SO <sub>2</sub> value
LAMP	mV	Voltage of the light intensity of the light source Standard value: 200 mV to 1200 mV
CELL	°C	Cell temperature Standard value: ambient temperature + (5°C to 15°C)
PUMP	kPa	Suction pressure of the pump Standard value: 65 kPa or less
AMBIENT	kPa	Current atmospheric pressure
SAMPLE	L/min	Sample flow rate (optional) Standard value: 0.6 L/min to 1.0 L/min
DC 24V	V	Power supply voltage inside the APSA-370 Standard value: 24 V ±0.5 V
DC 5V	V	Power supply voltage inside the APSA-370 Standard value: 5 V ±0.5 V

### 6.3.3 Hour meter

Press the [HOUR METER] button on the MENU/MAINTENANCE screen. The HOUR METER screen will be displayed.

This screen shows the cumulative operating hours of consumables.

If you reset this counts when replacing the corresponding consumables, the displayed count will help you determine the approximate time of the next replacement.

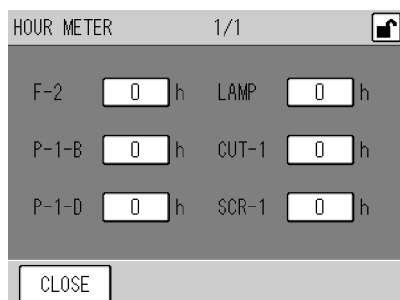

**Fig. 60 HOUR METER screen**

The operating hours of consumable parts are displayed.

For the symbols, see the flow sheet at the end of this document.

Use P-1-B for the pump itself and P-1-D for the pump diaphragm.

The following key allows you to perform the following operations.

[CLOSE]: Returns to the MENU/MAINTENANCE screen.

#### ● Changing the operating hours (resetting)

1. Press the button of the operating hour to be changed (reset).  
The HOUR METER screen for setting will be displayed.

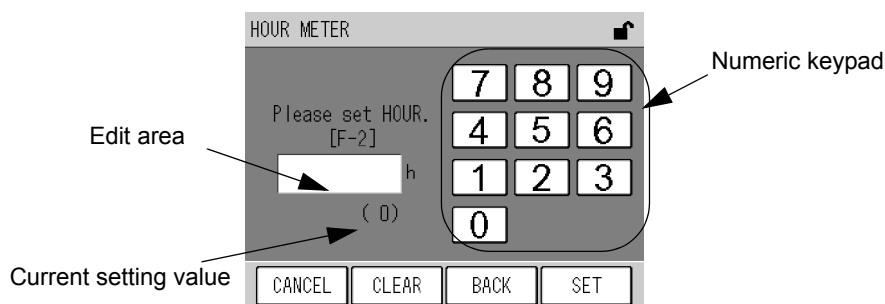

**Fig. 61 HOUR METER screen for setting**

Enter a value via the numeric keypad.

The keys allow you to perform the following operations.

- [CANCEL]: Returns to the HOUR METER screen without changing the time.  
 [CLEAR]: Deletes the value entered in the edit area.  
 [BACK]: Deletes the just entered figure (1-digit).  
 [SET]: Returns to the HOUR METER screen with the time changed.

2. Enter a desired value (0 for resetting) via the numeric keypad.
3. Press the [SET] key. The operating hours will be changed (reset) and the HOUR METER screen is displayed again.

### 6.3.4 Lamp history

Press the [LAMP HISTORY] button on the MENU/MAINTENANCE screen. The LAMP HISTORY screen will be displayed.

The lamp voltage is recorded every 4 days and displayed on this screen.

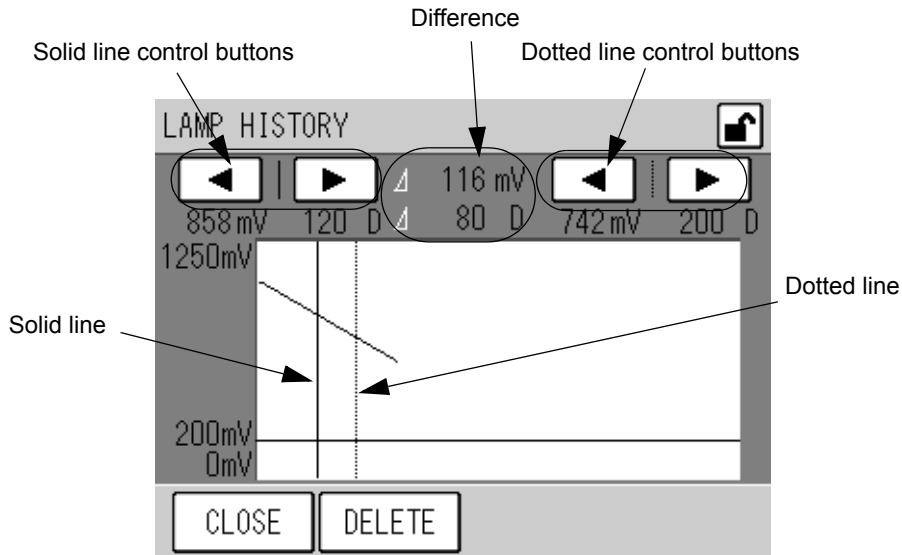

**Fig. 62 LAMP HISTORY screen**

The vertical axis shows voltage and the horizontal axis shows time in days.

Two vertical lines, solid and dotted, can be controlled with their respective buttons.

The following buttons allow you to perform the following operations.

- [◀]: Moves the line leftward.
- [▶]: Moves the line rightward.

The line position (elapsed time in days) and the lamp voltage at that time are displayed under the respective control buttons.

The difference between the two lines is displayed at the central part.

#### Note

The area below the horizontal line of the graph shows the alarm range. Once the lamp voltage falls within this area, an alarm will occur. When being above the horizontal line, the lamp voltage is normal.

The keys allow you to perform the following operations.

- [CLOSE]: Returns to the MENU/MAINTENANCE screen.
- [DELETE]: Displays the message confirming data deletion (Fig. 63 on page 51). This button is hidden when the keys are locked.

---

**● Deleting history**

The recorded lamp voltage data can be deleted at a time.

1. Press the [DELETE] button on the LAMP HISTORY screen.  
The message confirming data deletion will appear.

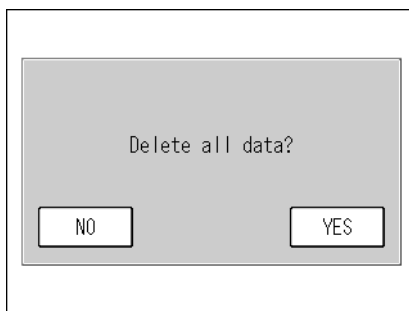

**Fig. 63** Message confirming data deletion

2. Press the [YES] button. The message of deleting data will be displayed and the data deletion will start. After the data deletion is completed, the LAMP HISTORY screen will be displayed again.

---

**Note**

To return the LAMP HISTORY screen without deleting the data, press the [NO] button.

---



**Fig. 64** Message of deleting data

## 6.4 Range Menu

The MENU/RANGE screen is used to change the analog output ranges by changing the full-scale setting.

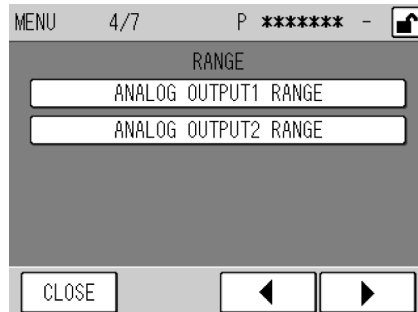

**Fig. 65 MENU/RANGE screen**

The buttons allow you to perform the following operations.

[ANALOG OUTPUT1 RANGE]: Displays the ANALOG OUTPUT1 RANGE screen (Fig. 68 on page 54).

[ANALOG OUTPUT2 RANGE]: Displays the ANALOG OUTPUT2 RANGE screen (Fig. 69 on page 54).

### ● ANALOG OUTPUT RANGE screens

The common functionalities to the ANALOG OUTPUT RANGE screens are described below: On the RANGE MENU screen, press the button of the range to be changed. The following ANALOG OUTPUT RANGE screen will be displayed.

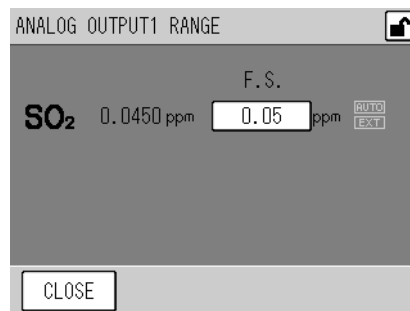

**Fig. 66 ANALOG OUTPUT RANGE screen (ANALOG OUTPUT1)**

This screen shows the current range status of each analog output signal.

[XXXX]: The range is currently set to XXXX ppm. Pressing this button allows you to change the range setting (see "● Changing range setting" (page 53)).

The currently used range type is displayed on the right of the range display.

AUTO: The automatic range switching is selected.

EXT: The external range switching is selected.

The following key allows you to perform the following operations.

[CLOSE]: Returns to the MENU/RANGE screen.

---

Tip

---

**Automatic range switching operation (for the standard specification)**

The combinations used for the automatic range switching depends upon the specification.

For the standard specification, all of the fixed ranges are used.

The analog output range for which the auto range switching is set changes automatically as follows:

- When the reading exceeds 90% of the current range, the measurement range will be switched to the next higher range.
  - If the reading drops below 80% of the next lower range of the current one, the measurement range will be switched to the lower range.
- 

● **Changing range setting**

1. On the ANALOG OUTPUT RANGE screen, press the button of the range to be changed. The RANGE screen will be displayed.

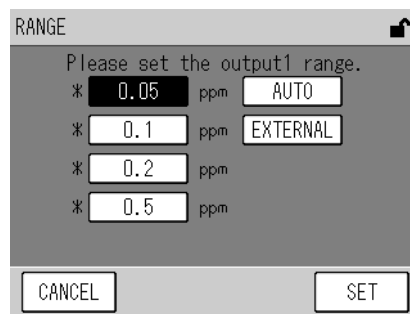

**Fig. 67 RANGE screen (OUTPUT 1)**

The range is set by choosing a button of range setting.

The keys allow you to perform the following operations.

[CANCEL]: Returns to the ANALOG OUTPUT RANGE screen without changing the settings.

[SET]: Returns to the ANALOG OUTPUT RANGE screen with the settings changed.

---

Tip

---

Among the fixed ranges, the ones for which an asterisk (\*) is displayed on the left of the button are available for the auto range switching. The combinations used for the automatic range switching depends upon the specification. For the standard specification, all of the fixed ranges are used.

---

2. Press the button of the range to be set.

**Note**

To use the external signal for range switching, select [EXTERNAL]. The external selection contact is optionally available.

---

3. Press the [SET] key. The range setting will be changed and the ANALOG OUTPUT RANGE screen is displayed again.

#### 6.4.1 ANALOG OUTPUT 1 range (momentary value)

Press the [ANALOG OUTPUT 1 RANGE] button on the MENU/RANGE screen. The ANALOG OUTPUT1 RANGE screen will be displayed.

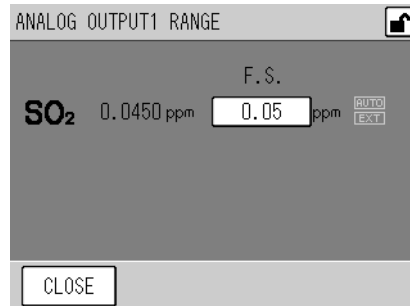

Fig. 68 ANALOG OUTPUT1 RANGE screen

For the screen functionalities, see " ● ANALOG OUTPUT RANGE screens" (page 52).

#### 6.4.2 ANALOG OUTPUT 2 range (rolling average)

Press the [ANALOG OUTPUT 2 RANGE] button on the MENU/RANGE screen. The ANALOG OUTPUT2 RANGE screen will be displayed.

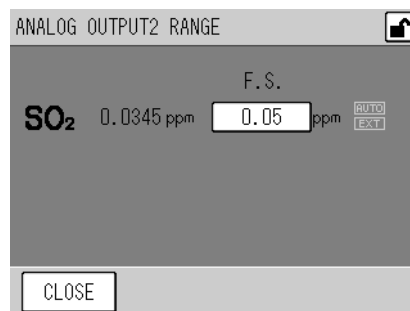

Fig. 69 ANALOG OUTPUT2 RANGE screen

For the screen functionalities, see " ● ANALOG OUTPUT RANGE screens" (page 52).

**Note**

For the analog output range, either the momentary value and rolling average (standard) or the momentary value and average value (optional) can be selected.



## 6.5 Setting Menu

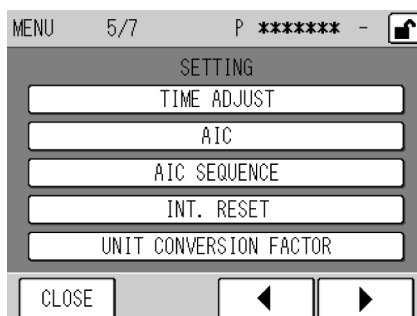

**Fig. 70 MENU/SETTING screen**

The buttons allow you to perform the following operations.

- [TIME ADJUST]: Displays the TIME ADJUSTMENT screen (Fig. 71 on page 56).
- [AIC]: Displays the AIC screen (Fig. 20 on page 16).
- [AIC SEQUENCE]: Displays the AIC SEQUENCE screen (Fig. 28 on page 22).
- [INT. RESET]: Displays the INT. RESET SETTING screen (Fig. 72 on page 57).
- [UNIT CONVERSION FACTOR]: Displays the UNIT CONVERSION FACTOR screen (Fig. 73 on page 58).

### 6.5.1 Time adjustment

Press the [TIME ADJUST] button on the MENU/SETTING screen. The TIME ADJUST screen will be displayed. This screen allows you to adjust the internal clock.

#### Note

Since the adjustment of the internal clock affects the data recording, give precautionary attention (see "● START TIME" (page 18)).

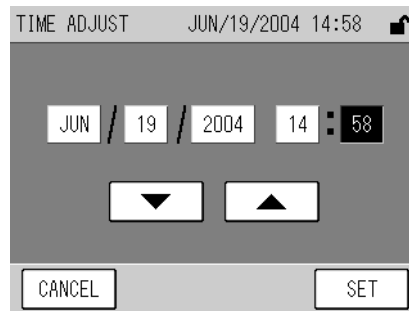

Fig. 71 TIME ADJUST screen

The current time setting is always displayed first, in a format of year, month, day, hour, and minute as respective buttons.

To change a value, press the corresponding button, and then press either of the following buttons to increase or decrease the value.

- [▲]: Increases the value.
- [▼]: Decreases the value.

The keys allow you to perform the following operations.

[CANCEL]: Returns to the MENU/SETTING screen without changing the settings.

[SET]: Returns to the MENU/SETTING screen with the settings changed.

#### Note

- If you press the [CANCEL] key before completing the setting, the time prior to the change will apply.
- The time cannot be set on a second basis. Pressing the [SET] key will automatically set the time to 00 second.
- If you change the time to any unrealistic date or time and press the [SET] key, the realistic date or time nearest to the set value will apply automatically.
- Pressing the [SET] key will delete the internal data (e.g., average) having the creation time later than the set time.

### 6.5.2 AIC setting

For the AIC setting, see "4.3.1 AIC setting" (page 16).

### 6.5.3 AIC sequence setting

For setting the AIC sequence, see "4.3.3 Setting the AIC sequence" (page 22).

### 6.5.4 Integration reset setting

Press the [INT. RESET] button on the MENU/SETTING screen. The INT. RESET SETTING screen will be displayed. This screen allows you to select a method for resetting the integration value, specify resetting time, and enable/disable the telemeter alarm.

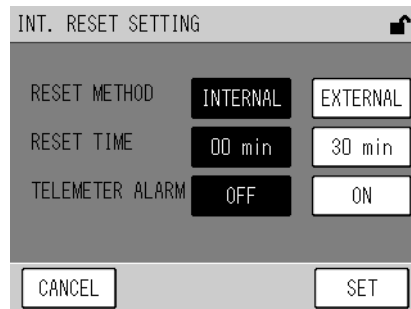

Fig. 72 INT. RESET SETTING screen

Item	Description
RESET METHOD	Select a method for resetting the integration value. INTERNAL: With the internal clock. EXTERNAL: With the external signal input.
RESET TIME	Specify the minute value to which the internal clock is adjusted at a integration reset. 00 min: The internal clock is adjusted to 00 min. 30 min: The internal clock is adjusted to 30 min.
TELEMETER ALARM	Specify whether or not to use the telemeter error signal. ON: The telemeter error signal is used. OFF: The telemeter error signal is not used.

#### Note

- When RESET METHOD is set to INTERNAL, no external reset signal will be accepted.
- If TELEMETER ALARM is set to ON, even when RESET METHOD is set to EXTERNAL and the telemeter error occurs (the telemeter error input contact is opened), the integration reset is performed with the internal clock. Besides, if AIC MODE is set to EXTERNAL (see “ 4.3.1 AIC setting ” (page 16)), the AIC sequence will be started with the internal clock automatically.

### 6.5.5 Unit conversion factor

Press the [UNIT CONVERSION FACTOR] button on the MENU/SETTING screen. The UNIT CONVERSION FACTOR screen will be displayed.

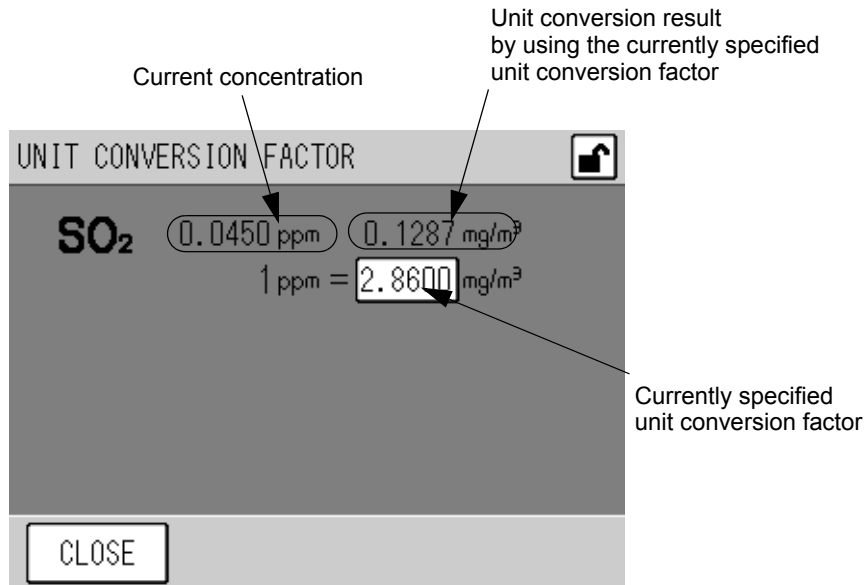

**Fig. 73 UNIT CONVERSION FACTOR screen**

For each measurement component, the current concentration and the conversion result by applying the currently selected unit conversion factor are displayed. This screen shows the current concentration in a different unit, and no setting on this screen affects the analog output and others.

The currently specified unit conversion factor is also displayed as a button.

To change the factor value, press the button of the factor to be changed (see " ● Changing the unit conversion factor" (page 59)).

The following key allows you to perform the following operations.

[CLOSE]: Returns to the MENU/SETTING screen.

● **Changing the unit conversion factor**

1. Press the button of the unit conversion factor to be changed. The **UNIT CONVERSION FACTOR** screen for setting will be displayed.

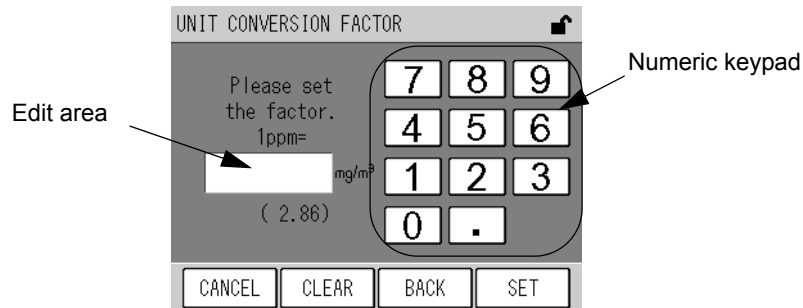

**Fig. 74 UNIT CONVERSION FACTOR screen for setting**

The currently select conversion factor is displayed in parentheses below the edit area.

Enter a value via the numeric keypad.

The keys allow you to perform the following operations.

- [CANCEL]: Returns to the UNIT CONVERSION FACTOR screen without changing the settings. The previous span gas concentration value will be used continuously.
- [CLEAR]: Deletes the value entered in the edit area
- [BACK]: Deletes the just entered figure (1-digit).
- [SET]: Returns to the UNIT CONVERSION FACTOR screen with the settings changed.

2. Enter a desired value via the numeric keypad.
3. Press the [SET] key. The factor will be changed and the **UNIT CONVERSION FACTOR** screen is displayed again.

## 6.6 System Menu

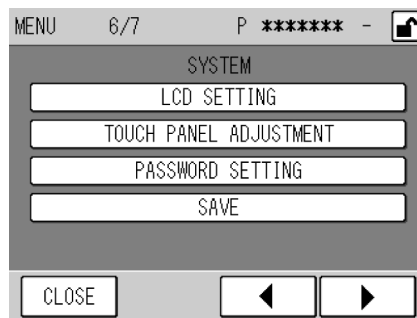

**Fig. 75 MENU/SYSTEM screen**

The buttons allow you to perform the following operations.

[LCD SETTING]: Displays the LCD SETTING screen (Fig. 76 on page 60).

[TOUCH PANEL ADJUSTMENT]:

Displays the TOUCH PANEL ADJUSTMENT screen (Fig. 78 on page 62).

[PASSWORD SETTING]:

Displays the PASSWORD SETTING screen (Fig. 80 on page 63).

[SAVE]:

Displays a message of saving data (Fig. 83 on page 65).

### 6.6.1 LCD setting

Press the [LCD SETTING] button on the MENU/SYSTEM screen. The LCD SETTING screen will be displayed.

This screen allows you to set the time for automatic turning OFF of the LCD backlight and control the LCD brightness.

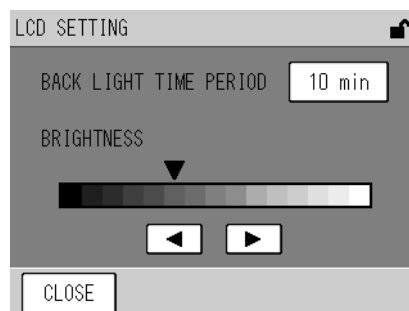

**Fig. 76 LCD SETTING screen**

The currently set time for automatic backlight OFF is displayed as a button.

[XX min]: Turns OFF the backlight after XX min (10 min, 20 min, or 30 min) from the last key operation.

[OFF]: Keeps the backlight illuminated.

To change the time setting, press the button of the time for automatic backlight OFF (see "● Setting the time for automatic backlight OFF" (page 61)).

The current brightness setting for the LCD is also displayed in position of the ▼ mark.

---

- **Setting the time for automatic backlight OFF**

1. Press the button of the time for automatic backlight OFF. The **BACK LIGHT TIME PERIOD** screen will be displayed.

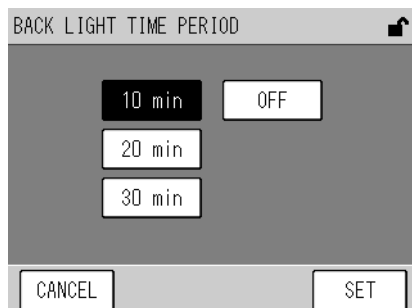

**Fig. 77 BACK LIGHT TIME PERIOD screen**

The time is set by choosing a button of time setting.  
The keys allow you to perform the following operations.

[CANCEL]: Returns to the LCD SETTING screen without changing the settings.

[SET]: Returns to the LCD SETTING screen with the settings changed.

2. Press the button of the time to be set.
3. Press the [SET] key. The time setting for automatic backlight OFF will be changed and the LCD SETTING screen is displayed again.

- **Controlling the LCD brightness**

Use the following button to control the LCD brightness.

[◀]: Decreases the brightness level of the screen.

[▶]: Increases the brightness level of the screen.

### 6.6.2 Touch panel adjustment

Press the [TOUCH PANEL ADJUSTMENT] button on the MENU/SYSTEM screen.

The TOUCH PANEL ADJUSTMENT screen will be displayed.

If the displayed buttons and keys deviate from their respective touch positions, you can adjust the touch panel by performing the following steps.

#### Note

Such deviations on the touch panel can be adjusted within a range of 36 dots.

If the positions deviate exceeding this limit, the following steps cannot be performed. Contact us.

#### Adjustment procedure:

1. Press the [TOUCH PANEL ADJUSTMENT] button on the MENU/SYSTEM screen. The TOUCH PANEL ADJUSTMENT screen (1) will be displayed.
2. Press the center of the area framed by 4 small triangles.

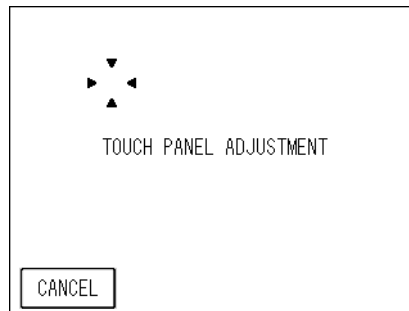

Fig. 78 TOUCH PANEL ADJUSTMENT screen (1)

3. The TOUCH PANEL ADJUSTMENT screen (2) will be displayed. Press the center of the area framed by 4 small triangles. The positions on the touch panel will be corrected and the MENU/SYSTEM screen will be displayed again.

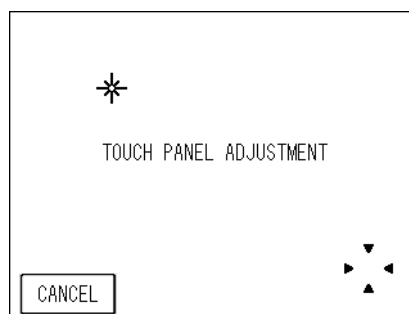

Fig. 79 TOUCH PANEL ADJUSTMENT screen (2)



---

### 6.6.3 Password setting

**Note**

The password is required to change the password.

---

1. Press the [PASSWORD SETTING] button on the MENU/SYSTEM screen.  
The PASSWORD SETTING screen will be displayed.

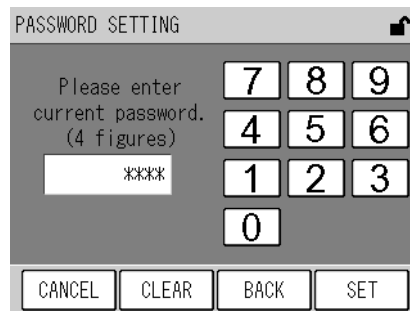

**Fig. 80 PASSWORD SETTING screen (requiring the current password)**

Enter a value via the numeric keypad.

The keys allow you to perform the following operations.

- [CANCEL]: Returns to the MENU/SYSTEM screen without changing the password.
- [CLEAR]: Deletes the value entered in the edit area
- [BACK]: Deletes the just entered figure (1-digit).
- [SET]: Changes the password to the value currently entered in the edit area.

2. Enter the current password in accordance with the message on the screen, and then press the [SET] key.  
If the entered password is correct, a message will appear prompting you to enter a new password.

**Note**

If the entered password is not correct, the procedure for changing the password will be aborted and the MENU/SYSTEM screen is displayed again.

---

**Tip**

The default password is 1234.

---

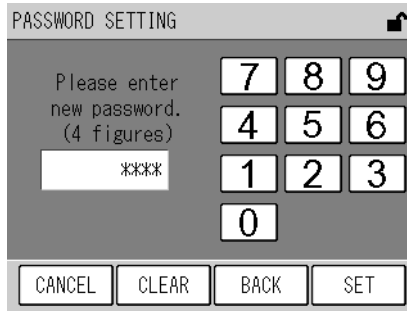
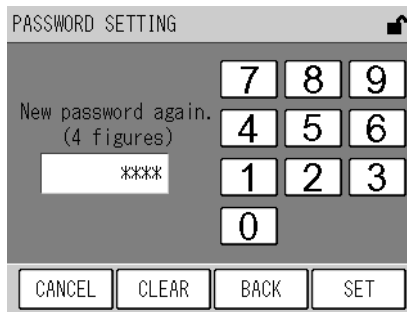

**Fig. 81 PASSWORD SETTING screen (requiring a new password)**

Enter a value via the numeric keypad.

The function of each key is the same as on the PASSWORD SETTING screen (requiring the current password) (Fig. 80 on page 63).

3. **Enter a new 4-character password in accordance with the message displayed on the screen and then press the [SET] key. A message will appear prompting you to verify the new password.**



**Fig. 82 PASSWORD SETTING screen (confirming a new password)**

Enter a value via the numeric keypad.

The function of each key is the same as on the PASSWORD SETTING screen (requiring the current password) (Fig. 80 on page 63).

4. **Enter the new 4-character password again in accordance with the message displayed on the screen and then press the [SET] key. If the re-entered password agrees with the new password, the current password will be changed and the MENU/SYSTEM screen is displayed again.**

**Note**

If the re-entered password does not agree with the new password, the procedure for changing the current password will be aborted and the MENU/SYSTEM screen is displayed again. In this case, the password is not changed.

---

### 6.6.4 Data saving

To save data in the memory manually, press the [SAVE] button on the MENU/SYSTEM screen. Before turning OFF the APSA-370, be sure to perform this operation to save the data that has not yet been saved in the memory.

#### Note

- The average and integration values are stored in the flash memory every 10 minutes. Before turning OFF the power, be sure to save those data in the memory.
- If accidental power outage occurs, data during a period of 10 minutes maximum may not be recorded.

1. Press the [SAVE] button on the MENU/SYSTEM screen. The message confirming the saving of the data will appear.

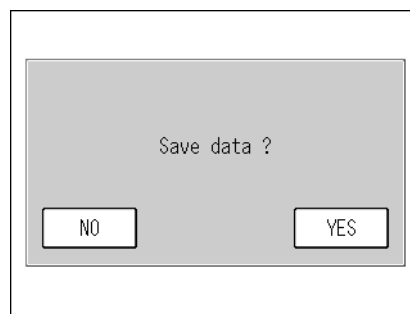

**Fig. 83 Message confirming the saving of the data**

The buttons allow you to perform the following operations.

[YES]: Saves the data in the memory.

[NO]: Saves no data to the memory and returns to the MENU/SYSTEM screen.

2. Press the [YES] button. The message of saving will be displayed and the data will start being saved. After the saving of the data is completed, the MENU/SYSTEM screen is displayed again.



**Fig. 84 Message of saving**

## 6.7 Communication Menu

TCP/IP SETTING on the second row is only displayed when Ethernet is enabled (optional).

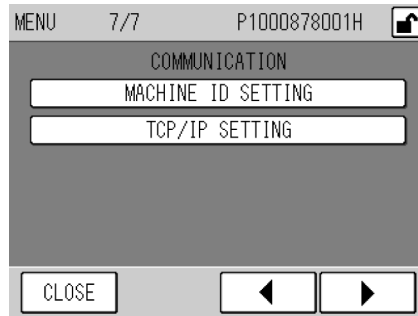

**Fig. 85 COMMUNICATION menu**

The buttons allow you to perform the following operations.

- [MACHINE ID SETTING]: Displays the MACHINE ID SETTING screen (Fig. 86 on page 67).
- [TCP/IP SETTING]: Displays the TCP/IP SETTING screen (Fig. 90 on page 70).

### 6.7.1 Machine ID setting

When the [MACHINE ID SETTING] button is pressed on the COMMUNICATION menu, the MACHINE ID SETTING screen will be displayed.

This screen allows you to set the machine ID that is the machine identification code when RS-232C and TCP/IP are used.

#### Note

Set the machine ID in a range between 0 and 249.

The machine ID and the corresponding intended use are shown below:

Machine ID	Intended use
0 to 249	Machine ID that can be set for each equipment piece
255	Machine ID that is used for maintenance and adjustments * Do not set the machine ID to 255.

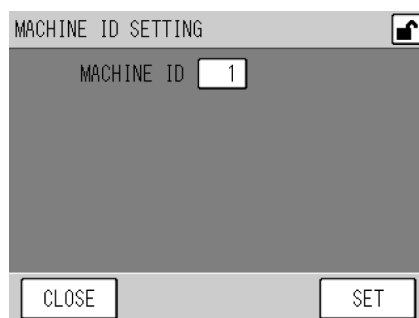

**Fig. 86 MACHINE ID SETTING screen**

Immediately after this screen has been displayed, the value for the currently set machine ID is displayed on the button.

Pressing the MACHINE ID button allows you to change that value. (See "● Changing the machine ID" (page 68).)

The keys allow you to perform the following operations.

[CLOSE]: Returns to the COMMUNICATION menu without changing the set value.

[SET]: Saves the changed value. To reflect the changed value, restart is required.

---

● **Changing the machine ID**

**1. Press the [MACHINE ID] button.**

The MACHINE ID screen will be displayed.

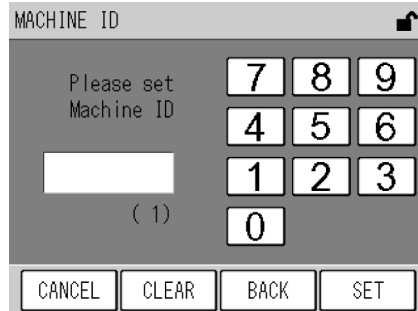

**Fig. 87 MACHINE ID screen**

The currently set machine ID is displayed in parentheses below the edit box. Use the numeric keypad to enter a value in the following range:

[Setting range]: 0 to 255

The keys allow you to perform the following operations.

- [CANCEL]: Returns to the MACHINE ID SETTING screen without changing the setting.
- [CLEAR]: Deletes the value entered in the edit box.
- [BACK]: Deletes the previously entered value (1-digit).
- [SET]: Establishes the changed value and then returns to the MACHINE ID SETTING screen.

**2. Use the numeric keypad to enter a desired value.**

**3. Press the [SET] key. You will return to the MACHINE ID SETTING screen.**

At this stage, the changed setting is not reflected. For the reflection of the setting, see "● Reflecting the machine ID setting" (page 69).

---

- **Reflecting the machine ID setting**

After the machine ID setting has been changed, the changed setting becomes effective when the APSA-370 is restarted.

To change the setting, be sure to restart the APSA-370.

- 1. Press the [SET] key on the MACHINE ID SETTING screen.**

The data will be written with a message screen displayed to show that the data is being saved.

After the data has been successfully written, a message screen will be displayed prompting you to restart the APSA-370.



**Fig. 88** Message screen showing that the data is being saved.

- 2. After the data has been successfully completed, a message screen will be displayed prompting you to restart the APSA-370.**

Press the [CLOSE] button to return to the COMMUNICATION menu.



**Fig. 89** Message screen prompting the user to restart the APSA-370.

- 3. Restart the APSA-370 (see “ 2.1 Start-up (Measurement Start) ” (page 4), “ 2.2 Shutdown ” (page 5)).**

### 6.7.2 TCP/IP setting

When the [TCP/IP SETTING] button is pressed on the COMMUNICATION menu, the TCP/IP SETTING screen will be displayed.

This screen allows you to complete the TCP/IP-related setting.

Setting	Value
IP ADDRESS	192 168 100 1
SUBNET MASK	255 255 255 0
DEFAULT GATEWAY	192 168 100 100
MAC ADDRESS	00-05-2B-11-22-33

**Fig. 90 TCP/IP SETTING screen**

Immediately after this screen has appeared, the currently set values for IP address, subnet mask, and default gateway are displayed on the corresponding buttons.

Pressing each IP ADDRESS button allows you to change the IP address (see page 71).

Pressing each SUBNET MASK button allows you to change the subnet mask (see page 72).

Pressing each DEFAULT GATEWAY button allows you to change the gateway (see page 73).

The displayed MAC address is fixed.

The keys allow you to perform the following operations.

[CLOSE]: Returns to the COMMUNICATION menu without changing the set values.

[SET]: Saves the changed values. To reflect the changed values, however, the APSA-370 must be restarted.



---

● **Changing the IP address**

**1. Press the IP ADDRESS button.**

The IP ADDRESS screen will be displayed.

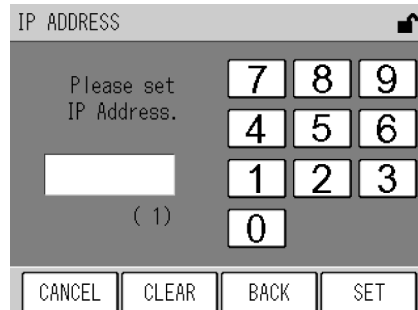

**Fig. 91 IP ADDRESS screen**

The currently set IP address is displayed in parentheses below the edit box. Use the numeric keypad to enter a value in the following range:

[Setting range]: 0 to 255

The keys allow you to perform the following operations.

- [CANCEL]: Returns to the TCP/IP SETTING screen without changing the setting.
- [CLEAR]: Deletes the value entered in the edit box.
- [BACK]: Deletes the previously entered value (1-digit).
- [SET]: Establishes the changed value and then returns to the TCP/IP SETTING screen.

**2. Use the numeric keypad to enter a desired value.**

**3. Press the [SET] key. You will return to the TCP/IP SETTING screen.**

At this stage, the changed setting is not reflected. For the reflection of the setting, see "● Reflecting the TCP/IP setting" (page 74).

## ● Changing the subnet mask

### 1. Press the SUBNET MASK button.

The SUBNET MASK screen will be displayed.

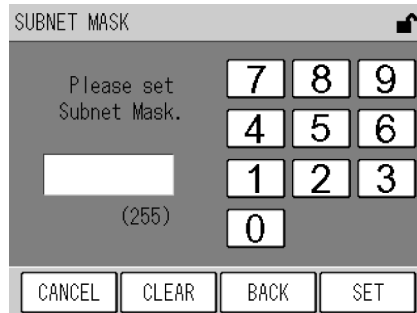

**Fig. 92 SUBNET MASK screen**

The currently set subnet mask is displayed in parentheses below the edit box.

Use the numeric keypad to enter a value in the following range:

[Setting range]: 0 to 255

The keys allow you to perform the following operations.

[CANCEL]: Returns to the TCP/IP SETTING screen without changing the setting.

[CLEAR]: Deletes the value entered in the edit box.

[BACK]: Deletes the previously entered value (1-digit).

[SET]: Establishes the changed value and then returns to the TCP/IP SETTING screen.

### 2. Use the numeric keypad to enter a desired value.

### 3. Press the [SET] key. You will return to the TCP/IP SETTING screen.

At this stage, the changed setting is not reflected. For the reflection of the setting, see "● Reflecting the TCP/IP setting" (page 74).

## ● Changing the default gateway

### 1. Press the DEFAULT GATEWAY button.

The DEFAULT GATEWAY screen will be displayed.

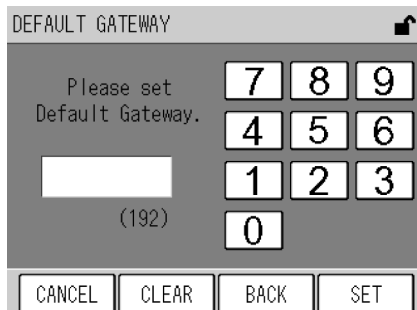

**Fig. 93 DEFAULT GATEWAY screen**

The currently set gateway is displayed in parentheses below the edit box.

Use the numeric keypad to enter a value in the following range:

[Setting range]: 0 to 255

The keys allow you to perform the following operations.

- [CANCEL]: Returns to the TCP/IP SETTING screen without changing the setting.
- [CLEAR]: Deletes the value entered in the edit box.
- [BACK]: Deletes the previously entered value (1-digit).
- [SET]: Establishes the changed value and then returns to the TCP/IP SETTING screen.

### 2. Use the numeric keypad to enter a desired value.

### 3. Press the [SET] key. You will return to the TCP/IP SETTING screen.

At this stage, the changed setting is not reflected. For the reflection of the setting, see "● Reflecting the TCP/IP setting" (page 74).

● **Reflecting the TCP/IP setting**

After the TCP/IP setting has been changed, the changed setting becomes effective when the APSA-370 is restarted.

To change the setting, be sure to restart the APSA-370.

**1. Press the [SET] key on the TCP/IP SETTING screen.**

The data will be written with a message screen displayed to show that the data is being saved.

After the data has been successfully written, a message screen will be displayed prompting you to restart the APSA-370.



**Fig. 94** Message screen showing that the data is being saved.

**2. After the data has been successfully completed, a message screen will be displayed prompting you to restart the APSA-370.**

Press the [CLOSE] button to return to the COMMUNICATION menu.



**Fig. 95** Message screen prompting the user to restart the APSA-370.

**3. Restart the APSA-370 (see “ 2.1 Start-up (Measurement Start) ” (page 4), “ 2.2 Shutdown ” (page 5)).**

## 6.8 Key Lock

When the [KEY LOCK] at the upper right corner of the screen is displayed in a box, pressing the [KEY LOCK] button displays the KEY LOCK screen.

This screen allows you to lock/unlock the keys.

### Note

The password is required to unlock the keys and to enter the supervisor mode.  
For password setting, see “6.6.3 Password setting” (page 63).

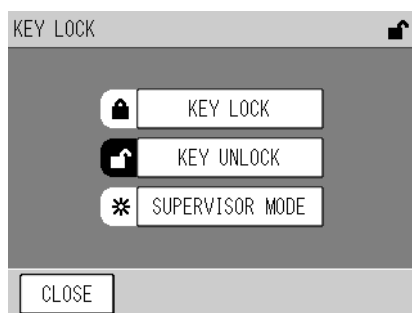

**Fig. 96 KEY LOCK screen**

When the keys are locked, the [KEY LOCK] icon is highlighted. When the keys are unlocked, the [KEY UNLOCK] icon is highlighted.

The buttons allow you to perform the following operations.

- |                    |   |
|--------------------|---|
| [KEY LOCK]:        | To lock the keys when the keys are unlocked, press this button. When the keys are locked, this button is invalid.   |
| [KEY UNLOCK]:      | To unlock the keys when the keys are locked, press this button, and then enter the correct password on the displayed PASSWORD screen (Fig. 97 on page 76).<br>When the keys are unlocked, this button is invalid. |
| [SUPERVISOR MODE]: | Displays the PASSWORD screen ( on page 76).<br>To enter the supervisor mode, which is used exclusively for our service maintenance, enter the correct password.   |

---

**● Entering the password**

1. Select a button on the KEY LOCK screen. The PASSWORD screen will be displayed.

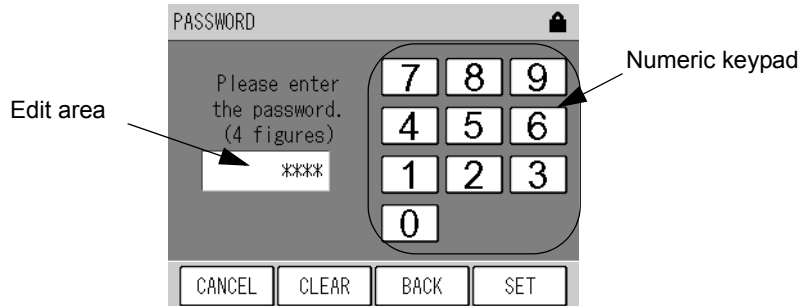

**Fig. 97 PASSWORD screen**

Enter a value via the numeric keypad.

The keys allow you to perform the following operations.

[CANCEL]: Cancels the password entry and returns to the KEY LOCK screen.

[CLEAR]: Deletes the value entered in the edit area

[BACK]: Deletes the just entered figure (1-digit).

[SET]: Enters the value in the edit area as a password.

2. Enter the 4-character password and then press the [SET] key.  
If the entered password is correct, the requested action will occur.  
If not correct, no action will occur and the PASSWORD screen will be displayed again.

---

Tip

The default password is 1234.

---

## 7 DAILY CHECKS

### 7.1 Before Maintenance

Prior to maintenance, perform the following steps to turn ON the maintenance switch.

When the maintenance switch is ON, the MNT signal is outputted via the signal connection terminal block.

Tip

For the terminal block output, see the rear panel signal table at the end of this document.

1. Press the [MAINT.] key on the MEAS. screen. The MAINTENANCE screen will be displayed.

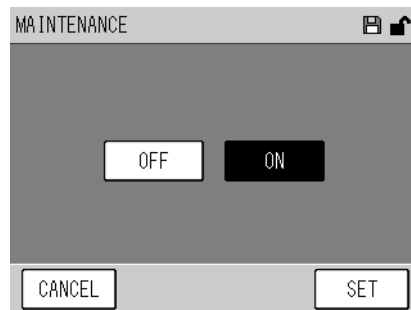

**Fig. 98 MAINTENANCE screen**

The current status of the maintenance switch is highlighted.

[ON]: Highlighted when the maintenance switch is ON.

[OFF]: Highlighted when the maintenance switch is OFF.

If the external switching is not selected, the status of the maintenance switch can be changed by pressing the [ON] or [OFF] button.

[ON]: Turns ON the maintenance switch.

[OFF]: Turns OFF the maintenance switch.

The keys allow you to perform the following operations.

[CANCEL]: Cancels the operation and returns to the MEAS. screen.

[SET]: Performs the operation and returns to the MEAS. screen.

2. Press the [ON] button.

3. Press the [SET] key.

## 7.2 Replacing the Filter Element

The filter element is used to purify the sample gas and protect the analyzer. If the filter element is used over a long period, the flow rate of the sample decreases.

### Recommended frequency of maintenance

- Filter element:  
About every 2 weeks (depending upon the sample conditions)

### Replacement procedure

1. Pull the knob to open the front panel.
2. Turn the filter cover leftward and then pull it out.
3. Remove the filter packing and filter element.
4. Attach a new filter element (or O-ring).
5. Turn the filter cover rightward to install it.
6. Close the front panel door.

Front panel (with the door opened)

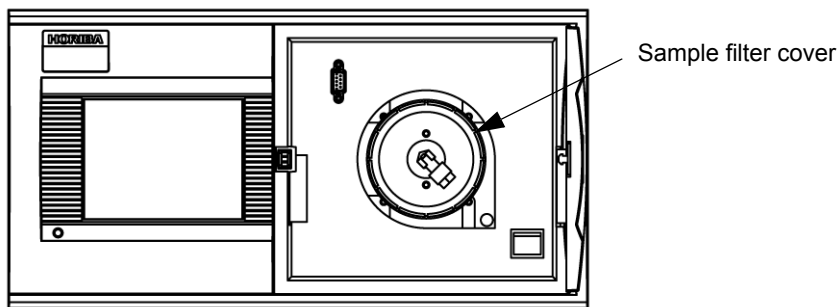

Sample filter case

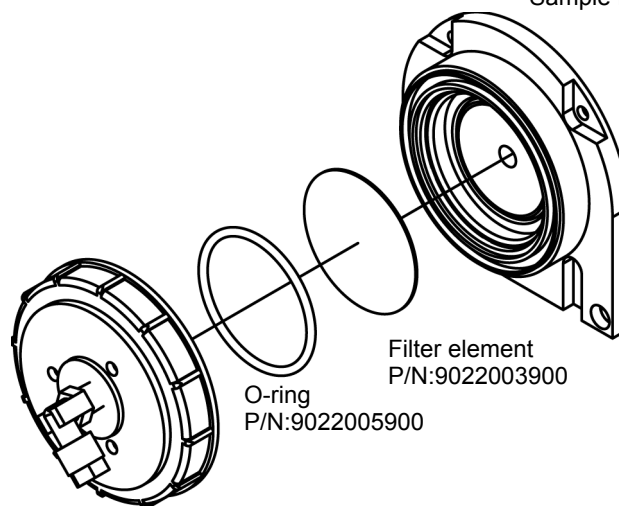

Sample filter cover

**Fig. 99 Exploded view of filter element**



### 7.3 List of Consumables and Replacement Parts

No.	Name	Specification	Qty.	Part No.	Replacement period
1	Filter element	PA-10L 54 mm in diameter × 0.5 (t) mm 24 pieces per package	1	9022003900	2 weeks
2	O-ring	JISB2401 G50	1	9022005900	1 year
3	Diaphragm assembly	EPDM for GS and GD series	2	9022002900	1 year
4	Air filter	0.3 μm	1	9026000200	1 year
5	Xenon lamp	L4646	1	9022003800	1 year
6	HC cutter assembly	3 m	1	9022003700	1 year
7	Scrubber	ESU-050A	1	9057003400	1 year
8	Pump unit	GD-6EH-100	1	9022005500	2 years
		GD-6EH-230	1	9022005600	2 years
9	LCD unit	For APXX	1	G0256120	3 years
10	Battery	CR2032	1	9022009800	3 years

#### Note

- The above replacement period is given as recommended and does not assure any performance. The replacement period of consumables may become shorter depending upon the installation environment and operating conditions.
- In order to maintain the accuracy, it is recommended that periodical maintenance and checks be performed when consumables are replaced. For information on maintenance and checks, etc., contact us.

## 8 TROUBLESHOOTING

### 8.1 Alarm Check

- **Alarm indicator**

When an error occurs in the analyzer, the [ALARM] key will be displayed on the lower right of the MEAS. screen. In addition, the Power ON LED will change from green to red.

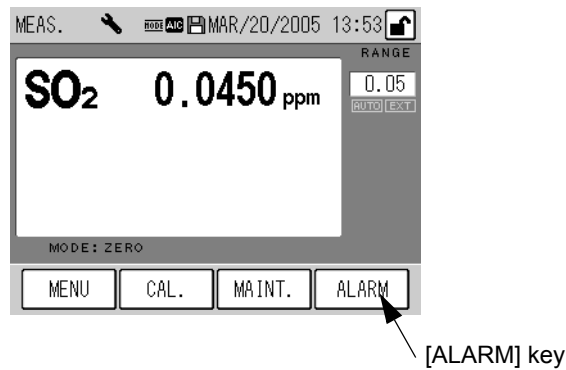
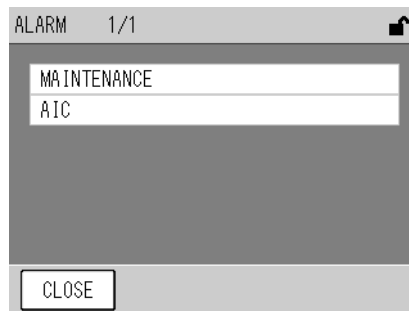

**Fig. 100 Alarm indicator**

- **ALARM screen: Checking the current alarm status**

This screen allows you to check the current alarm.

When an alarm occurs, the [ALARM] key will be displayed. Pressing this key displays the ALARM screen.



**Fig. 101 ALARM screen**

The currently occurring alarms are listed. One page can contain up to 6 alarm items.

A maximum of six alarms can be displayed on each page. If 7 alarms or more occurs, all the alarms can be viewed by turning pages with the function keys.

The keys allow you to perform the following operations.

- [CLOSE]: Returns to the MEAS. screen.
- [◀]: Displays the previous page.
- [▶]: Displays the next page.

### ● Alarm icon: Checking the data alarm status

The screen for data check displays an alarm icon to show that data has been acquired during the occurrence of an alarm.

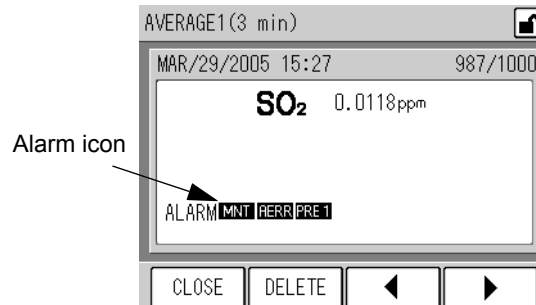

**Fig. 102 Alarm icon**

Alarms identified by the alarm icon displayed on the screen for data check are given below. For the possible cause and remedial action for each alarm, see the description in “ 8.2 Alarm List ” (page 82).

**Table 3 Alarms identified by alarm icons**

Alarm icon	Alarms	Reference	Remarks	Priority
POWR	Power ON	page 82	Hidden on the ALARM screen	high ↑ ↓ low
MNT	Maintenance	page 82		
AIC	AIC	page 82		
LINE	Line	page 82		
BATT	Battery	page 82		
CAL	Calibration	page 82	Hidden on the ALARM screen	
TELE	Telemeter failure	page 82		
AERR	AVAILABILITY error	page 83		
ZERO	Zero calibration	page 83		
SPAN	Span calibration	page 83		
PS_1	Pressure sensor 1 error	page 83		
PS_3	Pressure sensor 3 error	page 83		
TS_1	Temperature sensor 1 error	page 84		
LAMP	Light intensity	page 84		
PRE1	Pressure 1	page 84		
FLO1	Flow rate 1	page 85	optional	
I2C0	I <sup>2</sup> C communication error ID0	page 85		
CF	CF alarm	page 85	optional	

## 8.2 Alarm List

- **POWR: Power ON**

The power is turned ON.

This shows an operating status. No remedial action is required.

- **MNT: Maintenance**

The maintenance switch is turned ON via the MAINTENANCE screen. Otherwise, the maintenance contact is turned ON with an external signal.

This shows an operating status. No remedial action is required.

- **AIC: AIC**

The automatic calibration sequence is in progress.

This shows an operating status. No remedial action is required.

- **LINE: Line**

The measurement line is set to other than MEAS.

Otherwise, it is in the middle of the WAIT time for MEAS., which is specified in the AIC sequence, after line switching from ZERO or SPAN to MEAS.

This shows an operating status. No remedial action is required.

- **BATT: Battery**

The voltage of the battery for memory backup has decreased.

Possible cause	Remedial action	Reference
The battery reaches the end of its service life (about 3 years).	Replace the battery. If the settings return to the default value after the battery has been replaced, set the current time and AIC start time again.	---

### Note

For replacing parts, contact us.

- **CAL: Calibration**

Calibration is executed.

This shows an operating status. No remedial action is required.

- **TELE: Telemeter failure**

A telemeter error has occurred.

The telemeter input is OPEN only if a telemeter is connected.

Possible cause	Remedial action	Reference
No closed contact signal is received from the telemeter.	<ul style="list-style-type: none"> <li>● Check the telemeter.</li> <li>● Check the wiring.</li> </ul>	---

● **AERR: AVAILABILITY error**

This error occurs when effective data is short during the calculation of mean or cumulative data.

(when the number of effective data pieces is no larger than 90% of the total number of data pieces.)

This error does not mean any malfunction.

● **ZERO: Zero calibration**

The zero calibration is unsuccessful.

The zero calibration deviates from the specified range ( $\pm 3500$  counts).

Possible cause	Remedial action	Reference
The measured value is not stable.	Perform the zero calibration again.	page 27
Any gas other than the zero gas has been supplied during the zero calibration.	Supply the zero gas.	---

● **SPAN: Span calibration**

The span calibration is unsuccessful.

The span calibration deviates from the specified range (0.5 to 2.0).

Possible cause	Remedial action	Reference
The measured value is not stable.	Perform the span calibration again.	page 28
The Span gas concentration is wrong.	Check the span gas concentration and perform the span calibration with gas of the proper concentration.	---
The Span gas concentration is set improperly.	Set the span gas concentration properly.	page 14

● **PS\_1: Pressure sensor 1 error**

The pump pressure sensor or sensor circuit fails.

Possible cause	Remedial action	Reference
Sensor failure or circuit board failure	Contact us.	---

● **PS\_3: Pressure sensor 3 error**

The atmospheric pressure sensor or sensor circuit fails.

Possible cause	Remedial action	Reference
Sensor failure or circuit board failure	Contact us.	---

---

**● TS\_1: Temperature sensor 1 error**

The cell temperature sensor or sensor circuit fails.

Possible cause	Remedial action	Reference
Sensor failure or circuit board failure	Contact us.	---

**● LAMP: Light intensity**

Lamp voltage is below the specified voltage (200 mV).

Possible cause	Remedial action	Reference
The light intensity of the lamp is too low.	Replace the lamp.	---

---

**Note**

For replacing parts, contact us.

---

**● PRE1: Pressure 1**

Pressure deviates from the specified range.

The absolute pressure of the pump is 65 kPa or higher.

Possible cause	Remedial action	Reference
The piping has a leak or is disconnected.	Check to see whether the piping is connected properly. If the piping is disconnected, connect it properly. If your remedial action is unsuccessful, contact us.	page 3
The filter is contaminated.	Replace the sample filter element.	page 78
The pump has deteriorated.	If more than 2 years have passed since the replacement of the previous pump, replace the pump. Otherwise, contact us.	---

---

**Note**

For replacing parts, contact us.

---

---

● **FLO1: Flow rate 1 (optional)**

Flow rate deviates from the specified range.

Sample flow rate deviates from the specified range.

— Tip —

**Flow rate can be checked on the ANALOG INPUT screen (Fig. 59 on page 48).**

---

Possible cause	Remedial action	Reference
There is a leak on the measured gas line or the calibration gas line.	Check to see whether the measured gas line and the calibration gas line are connected properly. If either or both of these gas lines are disconnected, connect them properly. If your remedial action is unsuccessful, contact us.	page 3
The pump performance deteriorates or the pump stops.	Check the pump and diaphragm. If they have been used exceeding their replacement time, replace them. Replacement period of the diaphragm: Every year Replacement period of the pump unit: Every 2 years	---

---

**Note**

**For replacing parts, contact us.**

---

● **I2C0: I<sup>2</sup>C communication error ID0**

This is an internal error.

Contact us.

● **CF: CF alarm (optional)**

There is a problem with saving data to the CF during data logging.

Possible cause	Remedial action	Reference
The CF is not connected.	Insert a CF that has sufficient free space.	---
The CF has no free space.	Format the CF or insert a CF that has sufficient free space.	---

---

**Note**

**The data logging capability is optionally available.**

**For the CF-related features, refer to the Instruction Manual for APXX-370 Series Compact Flash Memory.**

---

## 8.3 Troubleshooting

This section describes troubleshooting mainly for the part replacement and checks, which are expected to be performed by the customer.

If your trouble is not rectified through these efforts, be sure to contact us.

### Note

Prior to taking your action, check the following points again:

- The power source is connected.
- The power supply voltage and capacity conform to the specifications.
- The replacement of parts is performed as specified.

### ● No output signal is available.

Possible cause	Remedial action	Reference
The flow rate is too low.	Check the measured gas line and calibration gas line for disconnected piping.	page 3
	Check to see whether the pump is operating.	---
The connector is disconnected.	Connect it properly.	page 3

### ● The output signal level is too low.

Possible cause	Remedial action	Reference
The range not set improperly.	Set the range properly or select the automatic range.	page 52
The zero calibration is not accurate enough.	Perform the calibration again.	page 27
The span calibration is not accurate enough.	Perform the calibration again.	page 28
The LAMP alarm occurs.	Replace the lamp.	---
The sample inlet or outlet has pressure loss.	Check the piping for clogging near the sample inlet or outlet. Rectify the piping for the sample inlet and outlet.	---
The filter is contaminated.	Replace the filter. Replacement period of the filter element: Every 2 weeks	page 78

### Note

For replacing parts, contact us.

### ● The output signal level is too high.

Possible cause	Remedial action	Reference
The range not set improperly.	Set the range properly or select the automatic range.	page 52
The zero calibration is not accurate enough.	Perform the calibration again.	page 27
The span calibration is not accurate enough.	Perform the calibration again.	page 28



---

● **The readings are not stable enough.**

Possible cause	Remedial action	Reference
The flow rate is unstable.	Check the filter. If the filter is found contaminated, replace it. Replacement period of the filter element: Every 2 weeks Replacement period of the air filter: Every year	page 78
	Check the pump and diaphragm. If they have been used exceeding their replacement time, replace them. Replacement period of the diaphragm: Every year Replacement period of the pump unit: Every 2 years	---

---

**Note**

**For replacing parts, contact us.**

---

● **The noise level is too high.**

Possible cause	Remedial action	Reference
Condensation occurs throughout the instrument.	Allow the instrument to stand for a while in an environment of stable temperature within the operating temperature range until condensation disappears.	---
The LAMP alarm occurs.	Replace the lamp.	---

---

**Note**

**For replacing parts, contact us.**

---

## 9 EXTERNAL INPUT/OUTPUT

The details of input/output depends upon the specifications.  
 This chapter describes the case that a standard circuit board, AP-RPL-02, is mounted.

### 9.1 Terminal Block Specifications

For the details of the terminal block specifications, see the rear panel signal table.  
 All outputs and all inputs are provided at contact points except for analog outputs.  
 The ON/OFF status is input/output as follows:



**Fig. 103 ON/OFF status of a contact terminal**

The functions of the terminals are described below:

#### 9.1.1 Range output for analog output

The current momentary value range is output as follows:

Output				Range
Range 1	Range 2	Range 3	Range 4	
ON	OFF	OFF	OFF	Range 1 (minimum concentration)
OFF	ON	OFF	OFF	Range 2
OFF	OFF	ON	OFF	Range 3
OFF	OFF	OFF	ON	Range 4 (maximum concentration)

#### 9.1.2 Contact input

**Note**

- The inputs of the AIC start and integration reset do not respond to the changes occurring within less than 0.1 second.
- The input of telemeter failure does not respond to the changes occurring within less than 0.5 second.

The executed operations depends upon the input status:

#### AIC start

When the AIC MODE is set to [EXTERNAL], changing this input from OFF to ON causes the following operation:

Instrument status	Operation
No AIC sequence is in progress.	Starts an AIC sequence
An AIC sequence is in progress.	Nothing

---

### 9.1.3 Contact output

#### AIC

This output is ON when the AIC sequence is in progress.

#### Maintenance

This output is ON during the maintenance mode.

### 9.1.4 Alarm output

This output shows that an alarm as described below is occurring.

#### Calibration error

This output is turned ON when the zero calibration error or span calibration error occurs.

#### General error

This output is turned ON when any alarm other than the AIC, MNT, ZERO, SPAN or Calibration error occurs.

The details of general error output vary depending upon the specifications. See the list of general errors at the end of this document.

For information on each alarm, see “ Table 3 Alarms identified by alarm icons ” (page 81) and “ 8.2 Alarm List ” (page 82).

### 9.1.5 Analog output

---

#### Tip

The analog output data can be set to any of the measurement value, AVERAGE 1, AVERAGE 2, AVERAGE 3, INTEGRATION, or ROLLING AVERAGE, as well as the standard setting.

---

These outputs are provided regardless of the MODE setting on the MEAS. screen.

### 9.1.6 Power shutoff output

#### Power shutoff

This output is ON when the power is OFF.

## 10 APPENDIX

### 10.1 Measurement Principle

When a sample is irradiated with ultraviolet ray (215 nm), SO<sub>2</sub> emits the light of a different wavelength (peak: 320 nm, range: 240 nm to 420 nm) from that irradiated. The former, irradiated light is referred to as excitation light, and the later, emitted light is referred to as fluorescence. The method to obtain sample concentrations by measuring the fluorescence intensity is called the fluorescence method. In the fluorescence method, fluorescence, which radiates in all directions, is usually detected at the right angles to the excitation light in order to prevent interference by the excitation light.

When excitation light is irradiated and absorbed:

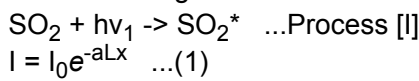

where I: intensity of the excitation light that passes through the cell  
 I<sub>0</sub>: initial intensity of the excitation light  
 a: absorption coefficient for the excitation light  
 L: cell length

Therefore, the amount of the excitation light absorbed in the cell, ΔI, is:

$$\Delta I = I_0 - I = I_0 (1 - e^{-aLx}) \quad \dots (2)$$

The number of the SO<sub>2</sub> excited in Process [I], SO<sub>2</sub><sup>\*</sup>, is proportional to the above ΔI.

$$[\text{SO}_2^*] = \Delta I / hv_1 \quad \dots (3)$$

There are three ways that the SO<sub>2</sub><sup>\*</sup>, which is generated in Process [I], loses its excitation energy.

- Fluorescence process: Excitation energy is emitted as fluorescence.

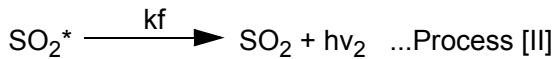

- Dissociation process: Excitation energy is used for dissociation.

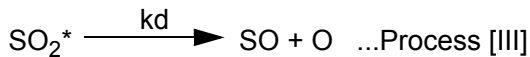

- Quenching process: Excitation energy is lost by collision with surrounding molecules, M.

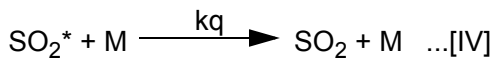

Practically, the excitation energy is lost resulting from the confluence of these three processes. Accordingly, the number of the SO<sub>2</sub><sup>\*</sup> that goes through the fluorescence process is:

$$\frac{k_f}{k_f + k_d + k_q [M]} [\text{SO}_2^*]$$

Therefore, the fluorescence intensity detected with the photomultiplier is expressed by the following equation, using the geometric constant of the cell, G:

$$I_f = G \cdot \frac{k_f}{k_f + k_d + k_q [M]} [\text{SO}_2^*]$$

$$= G \cdot \frac{I_0}{hv_1} \cdot \frac{k_f}{k_f + k_d + k_q [M]} (1 - e^{-aLx}) \quad \dots (4)$$

If the SO<sub>2</sub> concentration is low (1000 ppm or lower), the following equality is true and the fluorescence intensity is proportional to the SO<sub>2</sub> concentration, x:

$$I_f = G \cdot \frac{I_0}{hv_1} \cdot \frac{k_f}{k_f + k_d + k_q [M]} \cdot aLx \quad \dots (5)$$

## 10.2 Specification

Model	APSA-370	
Measurement target	Sulfur dioxide (SO <sub>2</sub> ) in atmospheric air	
Measuring principle	Ultraviolet fluorescence method	
Range	Standard	0 ppm to 0.05/0.1/0.2/0.5 ppm      Automatic range switching
	Optional	Max. 5 ranges between 0 and 0.05/10 ppm, Maximum range ratio: 20
Minimum detection sensitivity	For ranges of 0.2 ppm or less:    0.5 ppb (2σ)	
	For ranges exceeding 0.2 ppm:    0.5% (2σ) of the full scale	
Reproducibility (repeating accuracy)	±1.0% of the full scale	
Linearity (readout error)	±1.0% of the full scale	
Zero drift	For ranges of 0.2 ppm or less:    ±1.0 ppb/day, ±2.0 ppb/week	
	For ranges exceeding 0.2 ppm:    ±1.0% of the full scale /day ±2.0% of the full scale /week (ambient temperature change: within 5°C)	
Span drift	±1.0% of the full scale /day	
	±2.0% of the full scale /week (ambient temperature change: within 5°C)	
Response rate	180 s or shorter (T <sub>90</sub> from the inlet)	
Interference effect	NO 140 ppb:	±3 ppb (for range of 0.05 ppm)
	m-xylene 1 ppm:	±8 ppb (for range of 0.05 ppm)
	Moisture 2.5%:	±3 ppb (for range of 0.05 ppm)
Sample collection rate	Approximately 0.7 L/min	
Display	Measured value, alarm, time, alarm history, calibration history, etc.	
Alarms	Zero calibration, Span calibration, Light intensity etc.	
Input/output	0 V to 1 V (2 lines of momentary and rolling average values or average values)	
	Contact input/output (range, alarm, etc.)	
	RS-232C (optional)	
Ambient temperature	5°C to 40°C	
Ambient humidity	For lower than 31°C, the relative humidity must be 80% or lower.	
	For temperatures between 31°C and 40°C, the relative humidity must be below a linearly declining range from 80% at 31°C to 50% at 40°C .	
Altitude	3000 m above sea-level, or lower	
Power source	100, 115 V ±10 V AC 50/60 Hz, or 220, 230, 240 V ±10 V AC 50 Hz (depending upon the specifications)	
Power consumption	Approximately 150 VA in steady state	
External dimensions	430(W) × 221(H) × 550(D) mm	
Mass	Approximately 19 kg	
Connections	Sample inlet:	Joint for 6 mm O.D./ 4 mm I.D. Teflon tube
	Calibration gas inlet:	Joint for 6 mm O.D./ 4 mm I.D. Teflon tube
	Exhaust gas:	Joint for 6 mm O.D./ 4 mm I.D. Teflon tube

### 10.3 Unpacking

Unpack the package and check that the following items are included:

Checklist for items included	Check box
● Main unit 1 set	<input type="checkbox"/>
● Instructional materials 1 set	
Instruction manual: 1 copy	<input type="checkbox"/>
Communication (RS) guide (optional): 1 copy	<input type="checkbox"/>
● Standard accessories 1 set	
Power cable set: 1 piece	<input type="checkbox"/>
Filter elements (PA-10L, 24 pieces): 1 box	<input type="checkbox"/>

### 10.4 Installation

**Note**

To transfer the instrument, support its bottom by at least 2 persons.

#### 10.4.1 Installation environment

The APSA-370 has been designed for uses under general ambient conditions without assuming any use under special conditions. Install the APSA-370 in a location where the following conditions are met.

- Transient overvoltage of main power source:  
Overvoltage category II (IEC60364-4-443), Pollution level 2
- Fluctuation of power supply voltage: Reference voltage  $\pm 10\%$
- Power supply frequency: Reference frequency  $\pm 1\%$
- The ambient temperature shall be between 5°C and 40°C without any rapid change of 5°C or more.
- The location shall not be exposed to direct sunlight, hot air from a heater, and draft from an air-conditioner.
- The location shall be level.
- It shall be free from significant vibrations and any powerful electric or magnetic field.
- The dust level shall be 0.1 mg/m<sup>3</sup> or less.
- here shall be no corrosive gas.
- The relative humidity shall be 85% or lower.
- The altitude shall be 3000 m or less.
- A 3-pole power cable set shall be applicable.

#### 10.4.2 Installation place

- 19-inch standard rack
- Cut panel
- Flat desktop

As illustrated, this instrument requires 222 mm for its vertical space when installed on a 19-inch rack or cut panel.

It also requires 4 mounting screws and a supporting base.

For the mounting plate and sliding rails, use the optionally available ones.

To install the instrument on a desktop, remove its securing plates located on both sides, which are used for installation on a rack or cut panel.

For a rack or panel, use a supporting base for the bottom of the APSA-370.

**Service space**

Allow sufficient service space in front of, and behind the instrument.

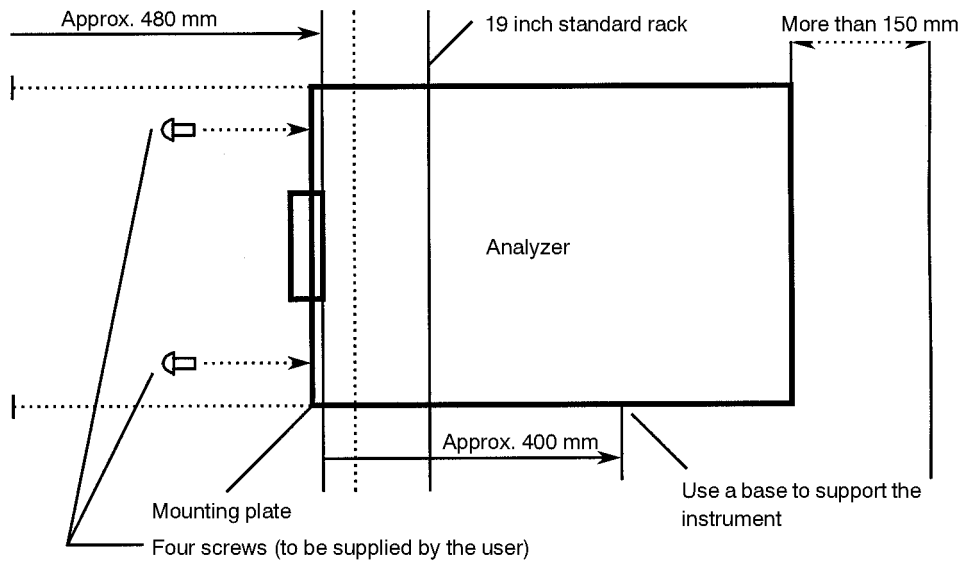

**Fig. 104 Mounting the APSA-370 on a 19-inch rack**

The following figure shows a cut panel and its screw positions.

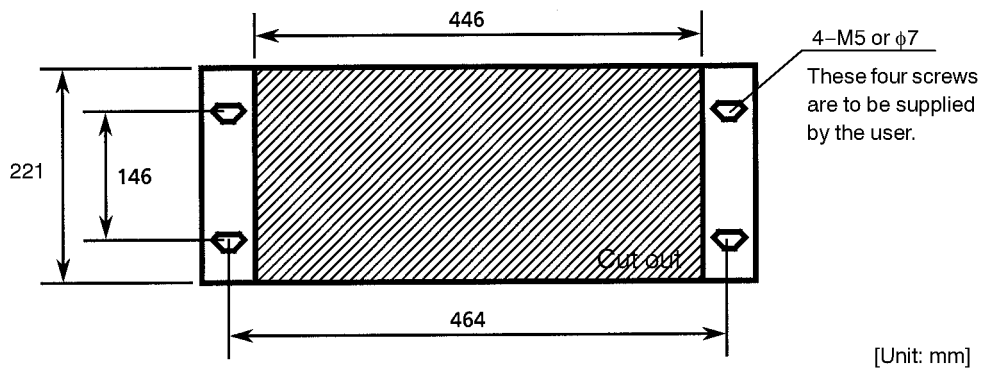

**Fig. 105 Mounting the APSA-370 on a panel**

As illustrated, place a supporting base behind the instrument.

**Note**

The mounting plate and sliding rails are available optionally.

## 10.5 Drawings

External dimensions:	V1022258
Flow sheet:	V1016117B
Rear panel signal table:	V1027818
A list of general errors:	V1027821



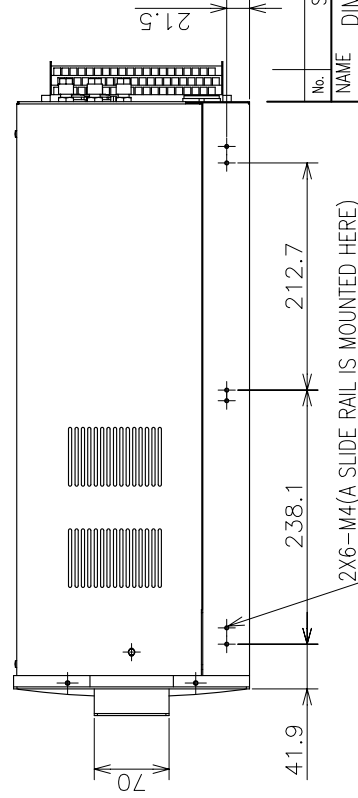
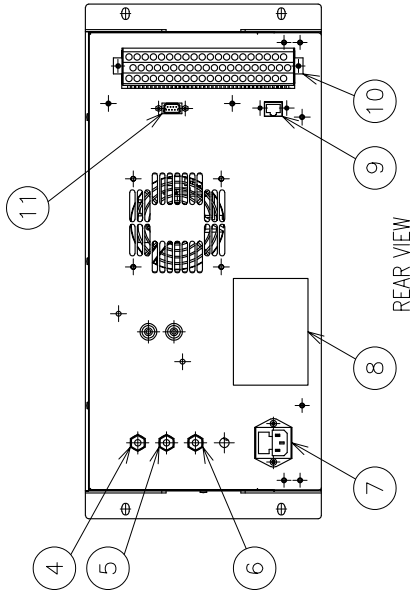
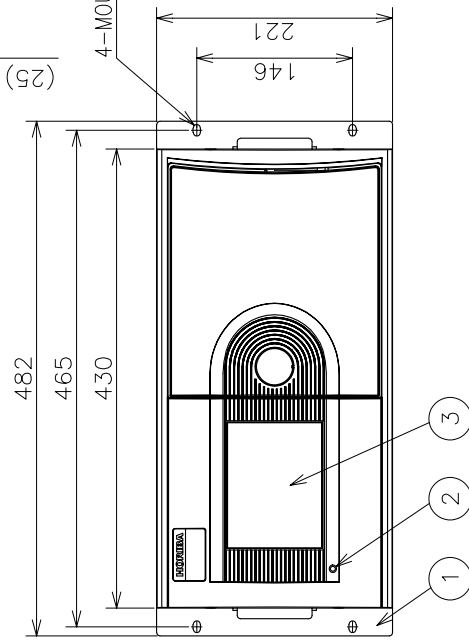
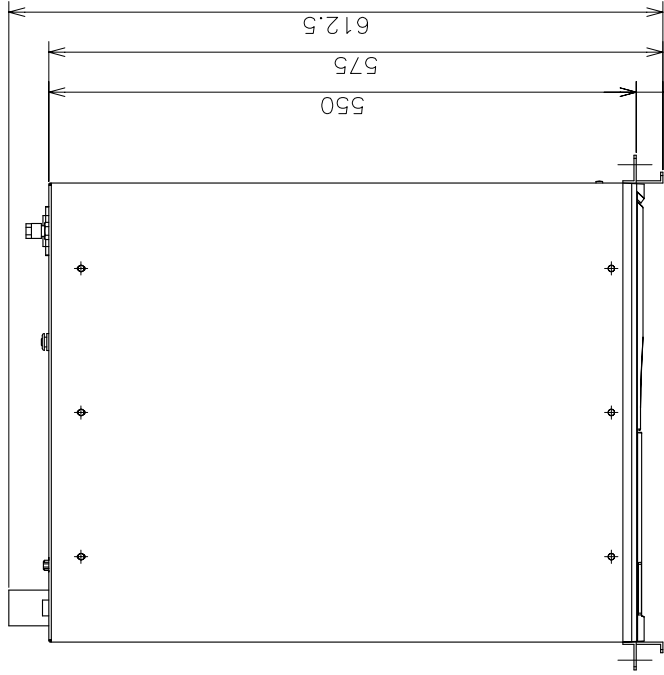

NO.	PARTS NAME	NOTES
1	FIXING PLATE 取付板	
2	POWER ON LED パワーオンLED	
3	DISPLAY PANEL 表示部	
4	CAL INLET 校正入口	φ6/φ4 TUBE FITTING
5	SAMPLE INLET サンプル入口	φ6/φ4 TUBE FITTING
6	EXHAUST 排気口	φ6/φ4 TUBE FITTING
7	POWER CONNECTOR 電源コネクタ	
8	GUIDE PLATE 配置銘板	
9	TCP/IP CONNECTOR TCP/IP 取合口	
10	I/O TERMINAL 入出力端子台	
11	RS232C CONNECTOR RS232Cコネクタ	

No.	SPEC.	PARTS NO.	NOTES
			DIMENSIONAL OUTLINE OF AMBIENT MONITOR AP-370 SERIES 外形寸法図 AP-370シリーズ
		SCALE 1:5	CAD DRAWING NO.
		DATE MAR.29.2004	V1022258

- NOTES) 1. ⑨,⑩ are optional specifications.  
2. ⑩ can be changed according to specifications.
- 注記) 1. ⑨,⑩ は、オプションとなります。  
2. ⑩ は、仕様により異なる場合があります。

DRAWN	CHECKED	APPROVED
A.TANIGUCHI	A.KAGAWA	A.KAGAWA

NO.	PARTS NAME	NOTES
1	FILTER フィルタ	
2	SOLENOID VALVE 3方電磁弁	
3	CUTTER カッター	
4	ANALYZER UNIT 分析部	
5	FLOW SENSOR フローセンサ	
6	ORIFICE オリフィス	
7	PRESSURE SENSOR 圧力センサ	
8	PUMP ポンプ	
9	CAPILLARY キャピラリー	
10	SCRUBBER スクラバ	

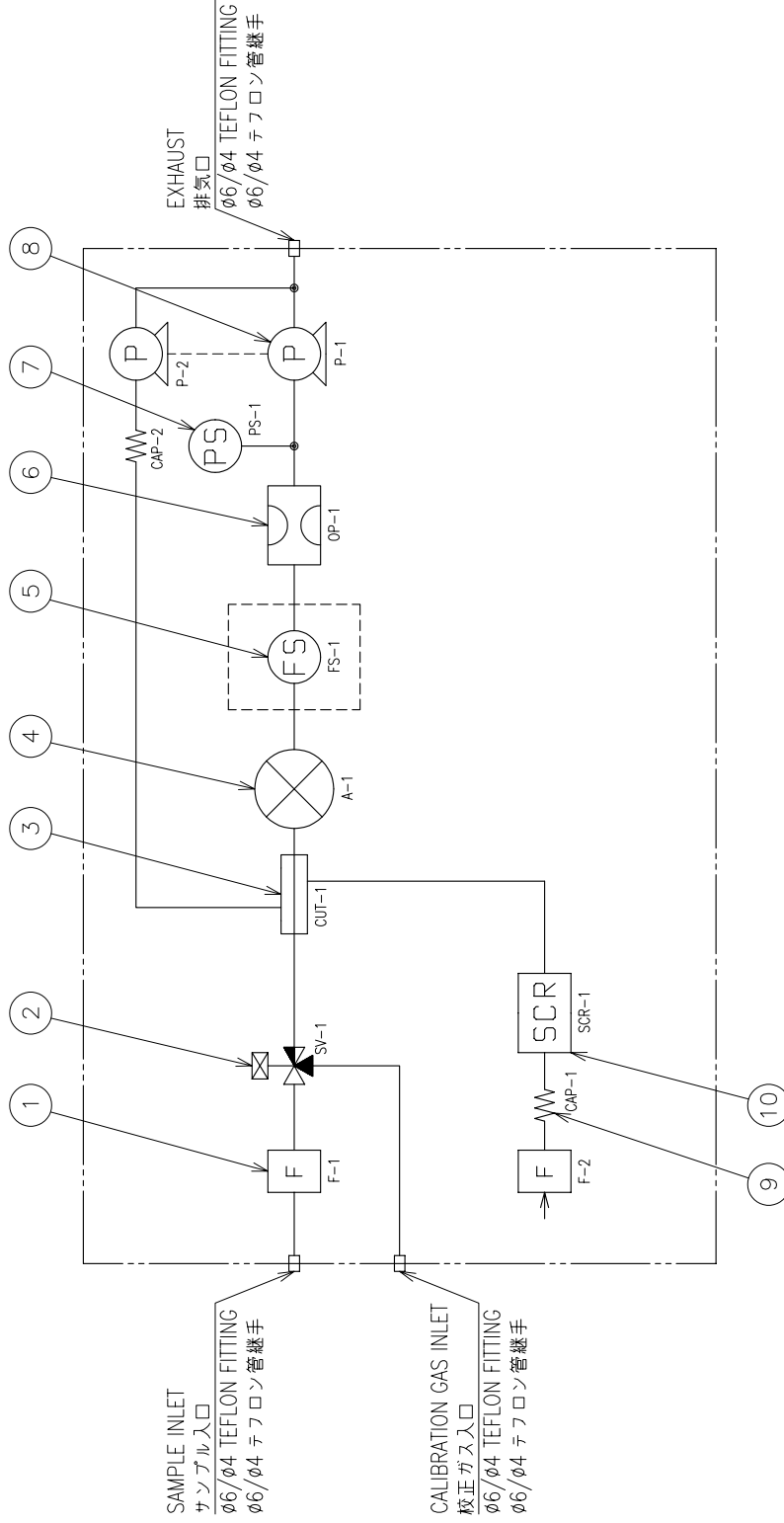

オプション  
OPTION

No.	SPEC.	PARTS.NO.	NOTES
	APSA-370		
FLOW SCHEMATIC OF AMBIENT SO <sub>2</sub> MONITOR 大気汚染監視用SO <sub>2</sub> 測定装置 フローシート			
SCALE		CAD DRAWING NO.	
FREE		V1016117B	
DATE		JUN.29,2004	

標準記号 NOTATION	訂正 CORRECTION	訂正者 A.TANIGUCHI	訂正日 JUN.28,2004
オプション OPTION <td>部分削除 PARTIAL ELIMINATION <td>A.TANIGUCHI <td>APR.27,2004 </td></td></td>	部分削除 PARTIAL ELIMINATION <td>A.TANIGUCHI <td>APR.27,2004 </td></td>	A.TANIGUCHI <td>APR.27,2004 </td>	APR.27,2004

DRAWN	CHECKED	REVISOR	APPROVED
A.TANIGUCHI	A.KAGAWA	A.KAGAWA	A.KAGAWA

SIGNAL TABLE

A 1	
A 2	
A 3	
A 4	option 1
A 5	during MNT
A 6	momentary value of SO <sub>2</sub>
A 7	COM
A 8	
A 9	
A 10	
A 11	
A 12	
A 13	
A 14	range 1
A 15	range 2
A 16	range 3
A 17	range 4
A 18	
A 19	common
A 20	

contact input

analog output  
(isolated)

contact output  
(range status of momentary  
value of SO<sub>2</sub>)

B 1	
B 2	
B 3	
B 4	start AIC
B 5	
B 6	option 2
B 7	
B 8	
B 9	
B 10	
B 11	
B 12	
B 13	
B 14	
B 15	
B 16	
B 17	
B 18	
B 19	
B 20	

contact input

C 1	momentary value of SO <sub>2</sub>
C 2	
C 3	
C 4	GND
C 5	rolling average of SO <sub>2</sub>
C 6	
C 7	
C 8	GND
C 9	option 3
C 10	
C 11	during AIC
C 12	
C 13	during MNT
C 14	
C 15	CAL alarm
C 16	
C 17	power down
C 18	
C 19	global error
C 20	

analog output  
(non-isolated)

contact output

EXPLANATION OF SIGNAL

- Analog output(isolated or non-isolated)  
Voltage output(DC0-1V)  
Output impedance : 100Ω or less
- Contact output  
Relay output  
Capacity : DC50V 0.1A MAX(resistive load)  
Relay switch : Normal open
- Contact input  
Open voltage : DC5V  
Short current : about 2mA  
More than 0.1sec close signal for "start AIC"
- Range status of momentary value(Relay output)  
Low concentration range range 1  
range 2  
range 3  
range 4  
High concentration range range 4
- Global error(Relay output)  
Close if more than 1 alarm occur  
Alarm list : V1027821
- Power down(Relay output)  
Close if power of APSA-370 is OFF

NOTES

- GND is connected to the case.
- COM is isolated from GND.

No.	SPEC.	PARTS.NO.	NOTES
-----	-------	-----------	-------

NAME APSA-370  
REAR PANEL SIGNALS LIST

SCALE  
FREE

DATE AUG.5.2004

CAD DRAWING NO.  
V1027818

<APXX-370 Alarm List>

Name of alarm	APOA	APMA	APSA	APNA	APHA	NOTE
Zero CAL	<input type="radio"/>	<input type="radio"/>	<input type="radio"/>	<input type="radio"/>	<input type="radio"/>	
Span CAL	<input type="radio"/>	<input type="radio"/>	<input type="radio"/>	<input type="radio"/>	<input type="radio"/>	
AIC	<input type="radio"/>	<input type="radio"/>	<input type="radio"/>	<input type="radio"/>	<input type="radio"/>	
Maintenance	<input type="radio"/>	<input type="radio"/>	<input type="radio"/>	<input type="radio"/>	<input type="radio"/>	
Flow 1	<input type="radio"/>	<input type="radio"/>	<input type="radio"/>	<input type="radio"/>	<input type="radio"/>	OPTION
Flow 2	<input type="radio"/>	<input type="radio"/>	<input type="radio"/>	<input type="radio"/>	<input type="radio"/>	OPTION
Pressure 1	<input type="radio"/>	<input type="radio"/>	<input type="radio"/>	<input type="radio"/>	<input type="radio"/>	
Pressure 2	<input type="radio"/>	<input type="radio"/>	<input type="radio"/>	<input type="radio"/>	<input type="radio"/>	
Converter Temp.	<input type="radio"/>	<input type="radio"/>	<input type="radio"/>	<input type="radio"/>	<input type="radio"/>	
Purifier Temp.	<input type="radio"/>	<input type="radio"/>	<input type="radio"/>	<input type="radio"/>	<input type="radio"/>	
Catalyzer Temp.	<input type="radio"/>	<input type="radio"/>	<input type="radio"/>	<input type="radio"/>	<input type="radio"/>	
Deoionizer Temp.	<input type="radio"/>	<input type="radio"/>	<input type="radio"/>	<input type="radio"/>	<input type="radio"/>	
NMC Temp.	<input type="radio"/>	<input type="radio"/>	<input type="radio"/>	<input type="radio"/>	<input type="radio"/>	
Flame	<input type="radio"/>	<input type="radio"/>	<input type="radio"/>	<input type="radio"/>	<input type="radio"/>	
Lamp	<input type="radio"/>	<input type="radio"/>	<input type="radio"/>	<input type="radio"/>	<input type="radio"/>	
Battery	<input type="radio"/>	<input type="radio"/>	<input type="radio"/>	<input type="radio"/>	<input type="radio"/>	
Press. sensor 1	<input type="radio"/>	<input type="radio"/>	<input type="radio"/>	<input type="radio"/>	<input type="radio"/>	
Press. sensor 2	<input type="radio"/>	<input type="radio"/>	<input type="radio"/>	<input type="radio"/>	<input type="radio"/>	
Press. sensor 3	<input type="radio"/>	<input type="radio"/>	<input type="radio"/>	<input type="radio"/>	<input type="radio"/>	
Temp. sensor 1	<input type="radio"/>	<input type="radio"/>	<input type="radio"/>	<input type="radio"/>	<input type="radio"/>	
Temp. sensor 2	<input type="radio"/>	<input type="radio"/>	<input type="radio"/>	<input type="radio"/>	<input type="radio"/>	
Temp. sensor 3	<input type="radio"/>	<input type="radio"/>	<input type="radio"/>	<input type="radio"/>	<input type="radio"/>	

No.	SPEC.	PARTS.NO.	NOTES
NAME APXX-370			
ALARM LIST			
 SCALE DATE AUG.5.2004	FREE	CAD DRAWING NO.	
		<b>V1027821</b>	

DRAWN A.AKASHI	REVISID	APPROVED
	CHECKED K.HARUTA	T.AOYAMA

# **HORIBA, Ltd.**

2 Miyanohigashi, Kisshoin Minami-ku, Kyoto 601-8510 Japan  
<http://www.horiba.com>

---