

**Residual chlorine concentration monitor
UP-400CL**

Instruction Manual [eng]

CODE:GZ0000659065A

Be sure to read this manual before using the product to ensure proper and safe operation of the product.

In particular, be sure to read "1.1.1 Safety precautions" (page 1) before using the product to ensure safe operation.

Also store the manual safely so that it is readily available whenever necessary.

Manual information

This manual describes the operations and tasks to use the product name, UP-400CL.

This manual is an original instruction manual produced by Horiba Advanced Techno.

If you have any questions or concerns about safety during use, please contact us.

Product specifications and appearance, as well as the contents of this manual are subject to change without notice.

In addition, the contents described in this document are subject to change without notice. Please note.

■ Warranty and responsibility

The warranty period for this product is one year after delivery. However, if the warranty period is separately stipulated in a written contract, that contract shall take precedence. In the unlikely event that a failure occurs due to our responsibility during the warranty period, we will repair or replace parts free of charge. However, cases like next are excluded from the warranty;

- Any malfunction or damage attributable to improper operation
- Any malfunction attributable to repair or modification by any person not authorized by HORIBA Advanced Techno, Co., Ltd.
- Any malfunction or damage attributable to the use in an environment not specified in this manual
- Any malfunction or damage attributable to violation of the instructions in this manual or operations in the manner not specified in this manual
- Natural disasters or other force majeure or malfunctions resulting therefrom (Examples: wind storms, torrential rains, storm surges, earthquakes, lightning strikes, floods, land subsidence, fires, tsunamis, eruptions, etc.)
- In case of failure due to dropping the product
- Any deterioration in appearance attributable to corrosion, rust, and so on
- Replacement of consumables

We are not responsible for any incidental damage (change or loss of data, loss of business profit, loss of opportunity, etc.) arising from the use or inability to use this product.

■ Documents related to this product

The following documents are related to this product.

- UP-400CL Instruction manual (this manual)

The manual, which is referred to as "this manual" in this manual, describes the operations and tasks to use the product.

- UP-400CL Quick manuals

This section describes the operations and work required if you want to start concentration measurement immediately.

■ Target reader

This manual is intended for users and installation of this product.

■ Part names and terms

The part names of this product are defined in "2.3 Description of each part" (page 5).

In this manual, SD memory card, SDHC memory card, microSD memory card*, microSDHC memory card*, miniSD memory card* and miniSDHC memory card* are referred to as "SD memory card".

*When using with this product, be sure to attach the dedicated conversion adapter.

■ Trademarks

- QR code is a registered trademark of DENSO WAVE INCORPORATED.
- SD, SDHC, microSD, microSDHC, miniSD and the miniSDHC logo are trademarks of SD-3C, LLC.



Other company names and brand names are either registered trademarks or trademarks of the respective companies. (R), (TM) symbols may be omitted in this manual.

■ Signal words and markings

The following signal words and markings are used in this document.

● Signal words for warning messages

Personal safety-related information is classified according to the degree of harm on the product and in this manual.

Warning messages start with the following signal words in this manual.



This indicates an imminently hazardous situation which, if not avoided, will result in death or serious injury. This is to be limited to the most extreme situations.



This indicates a potentially hazardous situation which, if not avoided, could result in death or serious injury.



This indicates a potentially hazardous situation which, if not avoided, may result in minor or moderate injury.

The information may be combined with the following graphical symbols in this manual.

Symbol	Description
	Prohibition: This symbol indicates what shall not be done.
	Mandatory: This symbol indicates what shall be done.

● Other signal words

Note	This indicates the information that requires special attention to use the product properly. This also indicates the information to prevent property damages.
Tip	This indicates reference information.
Reference	This indicates the part where to refer for information.

● Special punctuation marks

Mark	Description
" "	These marks are used when citing messages displayed on the touch screen. These marks are also used for emphatic wording or references.

Contents

1	Preface	1
1.1	For your safety	1
1.1.1	Safety precautions	1
1.2	Operational precautions	2
2	Outline	3
2.1	Introduction	3
2.2	Machine configuration	3
2.3	Description of each part	5
2.3.1	The main unit	5
2.4	Screen description	8
3	Installation	9
3.1	Installation environment conditions	9
3.2	Confirmation of the contents	9
3.3	Installation of the main unit	10
3.4	Tube connection	12
3.5	Power supply	13
3.5.1	Connection between main unit and AC adapter	14
4	Measurement	15
4.1	Start/stop	15
4.2	Preparation for measurement	16
4.3	Measurement start and stop	16
4.3.1	Displaying the calibration screen from the measurement screen	17
4.3.2	Displaying the history screen from the measurement screen	17
4.4	Measurement operation	18
5	Calibration	19
5.1	Manual Cal.	20
5.2	Real-time calibration	21
5.2.1	Zero calibration	21
5.2.2	Span calibration	22

6	Settings (Menu)	23
6.1	Settings item list	23
6.2	Meas. Setting	24
6.2.1	Mode Select	25
6.2.2	Meas. Interval (min.)	27
6.2.3	Meas. Times after Int.	28
6.2.4	Number of Moving Ave.	29
6.2.5	HCIO or CIO-ratio	30
6.3	Cal. Setting	31
6.3.1	Manual Cal.	31
6.3.2	Clear Cal. Parameters	31
6.4	Error Setting	32
6.4.1	Low Chlorine Error	32
6.4.2	High Chlorine Error	33
6.4.3	Low Temp. Error	34
6.4.4	High Temp. Error	35
6.5	General Setting	36
6.5.1	Device ID Setting	36
6.5.2	Date/Time Setting	37
6.5.3	Brightness	38
6.5.4	Factory Reset	39
6.5.5	Pump Reset	40
6.5.6	QR code of Instructions	41
6.6	Cal. Result History	42
6.7	Error History	43
6.8	Delete History Data	44
6.8.1	Delete the error history (Error History)	44
6.8.2	Delete the calibration result (Cal. Result History)	45
7	Save data to SD memory card	46
7.1	Detachment of SD memory card	47
7.1.1	Attachment of the SD card	47
7.1.2	Ejection of the SD card	48
7.2	Save data	49
7.2.1	SD data file format	49
8	Errors and countermeasures	50
8.1	Error list and countermeasures	50
8.2	Problems without error display	52

9	Communication and Input/Output specifications	53
9.1	Overview	53
9.2	Communication parameters	53
9.3	Communication protocol	54
9.4	Command format	54
9.5	Command reception table	55
9.6	Measurement sequence (example)	56
9.7	Communication commands to host computer	57
9.8	Communication cable connection	63
9.8.1	RS-232C connection	63
9.9	Communication unit connection	64
9.9.1	RS-232C connection	65
9.10	Terminal block connection	66
9.10.1	Electrical current output connection	67
9.10.2	Signal input/output connection	68
10	Maintenance	70
10.1	Contact for maintenance	70
10.2	List of replacement parts	70
10.3	Maintenance item	71
10.4	Daily maintenance	71
10.5	Periodical maintenance	71
10.6	Sensor and pump replacement	72
10.6.1	Sensor replacement	72
10.6.2	Pump replacement	73
10.7	Care for moving	74
10.8	Long suspension	74
11	Disposal of the product	75
11.1	Body disposal	75
11.2	Communication unit disposal	76
12	Reference	77

12.1	Regulations	77
12.1.1	EU regulations	77
12.1.2	FCC rules	78
12.1.3	Korea certification	78
12.1.4	Taiwan battery recycling mark	78
13	Document	79
13.1	Measuring principle	79
13.2	Specifications	81
13.3	Watch the operation in the video	83





1 Preface

This chapter provides the precautions on overall using this product.
Follow the instructions and use this product safely and correctly.

1.1 For your safety

1.1.1 Safety precautions

This section provides precautions for using the product safely and correctly.

 WARNING	
	<p>Danger of fire</p> <ul style="list-style-type: none">• For your safety, make sure to unplug the power plug from the electrical outlet when not in use.• If the power plug is not firmly plugged into the electrical outlet, insert the power plug firmly into the electrical outlet.• Clear dust on the power plug periodically a few times a year. <p>If the power supply cord is left plugging into the electrical outlet for a long period of time, electrical tracking may occur due to dust and moisture, and it may result in an ignition or a fire.</p>
	<p>Danger of fire and electrical shock</p> <ul style="list-style-type: none">• Do not bundle the power supply cord during use.• Do not damage the power supply cord nor apply an excessive load to it, such as bending and stretching it repeatedly, putting a heavy thing on it. <p>It may result in overheating, a fire, an electrical shock, or breakdown.</p>
	<p>Danger of fire and electrical shock</p> <p>Do not apply an excessive load to the cables, such as bending and stretching them repeatedly, putting a heavy thing on them.</p> <p>Otherwise such a load may cause a fire, electric shock, or breakdown.</p>

1 Preface

1.2 Operational precautions

1.2 Operational precautions

Use of the product in a manner not specified by the manufacturer may impair the protection provided by the product, and it may also reduce product performance.

Therefore, pay attention to the following precautions.

- Do not use this product and its accessories for purposes other than those specified.
- Do not give a shock to this product by dropping or hitting it.
- Do not wipe the instrument with strong acid, strong alkali or organic solvent.
- This product has a waterproof structure equivalent to IPX4 grade.
However, it does not guarantee non-destructive, trouble-free and waterproof performance in all conditions.
- Environmental conditions such as electromagnetic noise may affect RS-232C communication and analog output.
- Do not press the keys with a sharp object.
- If the power supply is failed while saving measurement data to the internal memory of the instrument or SD memory card, the data may be damaged.
- Use water that complies with the supply act.

2 Outline

2.1 Introduction

The Residual Chlorine Concentration Monitor UP- 400CL is a device that measures the residual chlorine concentration contained in the rinsing liquid used to sterilize vegetables.

The residual chlorine can be continuously monitored in real time.

Sample will be introduced automatically by the pump installed in the main unit to measure the residual chlorine. Measurement can be done easily when installing the monitor near the rinsing bath.

2.2 Machine configuration

The UP-400CL has three types of configurations as follows:

(i) Standard model: The main unit is installed alone without communication.

(ii) Digital communication model: Used by connecting the main unit to a PC or PLC with a dedicated cable.

(iii) Analog communication model: Used by connecting the main unit to a PLC through the communication unit.

	(i) Standard model UP-400CL-0	(ii) Digital communication model UP-400CL-1-0-**	(iii) Analog communication model UP-400CL-1-1-**
Save data in the SD memory card	✓	✓	✓
Digital communication	–	✓	✓
Analog output	–	–	✓
I/O input/output	–	–	✓
Cable length	2 m (To the DC jack)	Select among from 1 m, 5 m, 10 m	Select among from none, 1 m, 5 m, 10 m (Extension cable length to the communication unit)
Accessories	AC adapter	–	Communication unit

2 Outline

2.2 Machine configuration

● Configuration of the models

The following illustration is just for an image, and the scale is neglected.

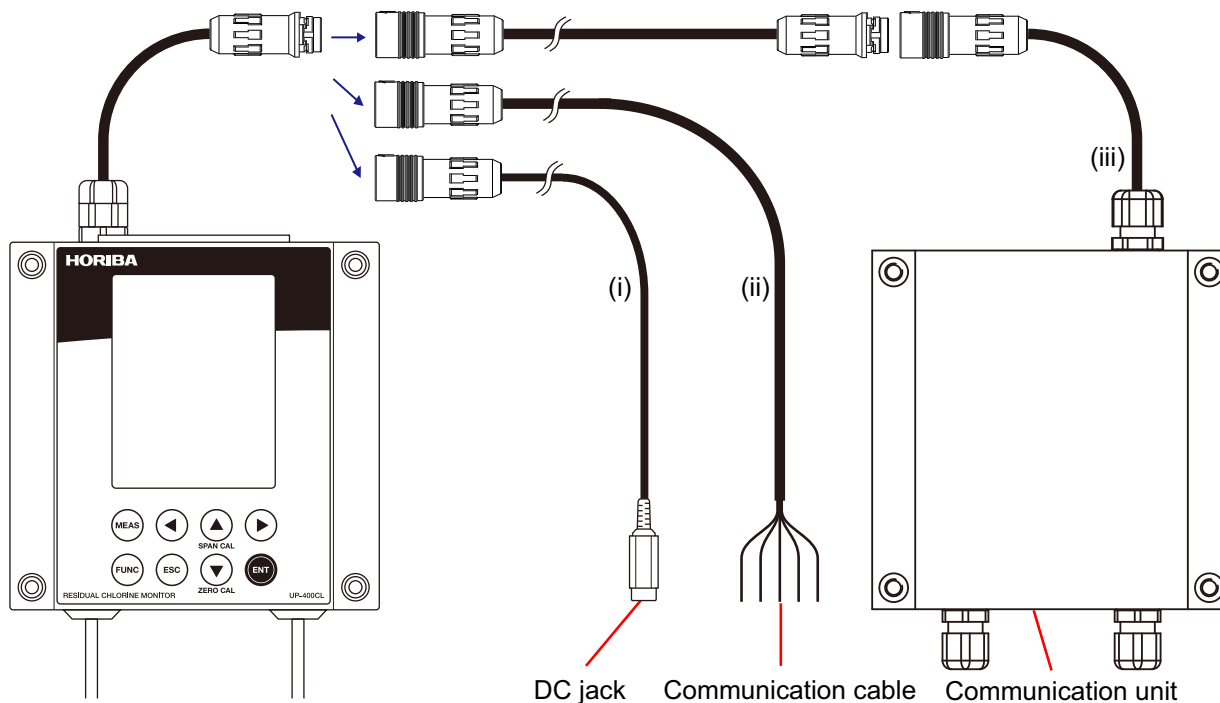

● Model reference

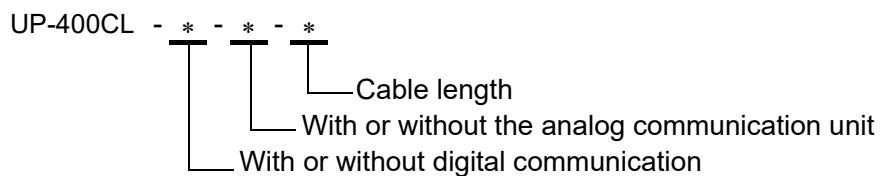

Main unit	UP-400CL	Residual chlorine concentration monitor main unit	
Digital communication	-0	Without digital communication	
	-1	With digital communication	
Communication unit with analog output	-0	Without communication unit	
	-1	With communication unit	
Cable length	-0	No cable	
	-1	1 m	
	-5	5 m	
	-10	10 m	

2.3 Description of each part

2.3.1 The main unit

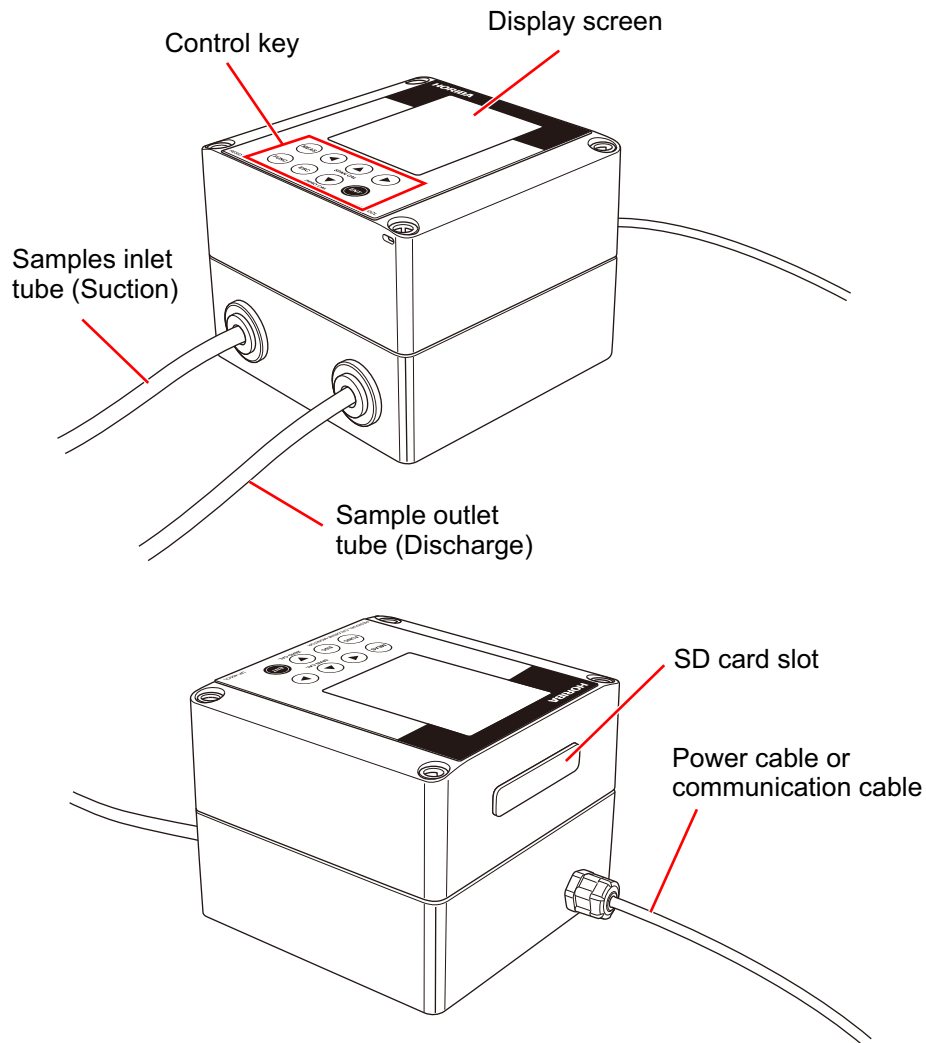

Brief explanation of each function.

Name of function	Function
Display screen	Displays the residual chlorine concentration, temperature, etc.
Control key	Used when controlling or selecting modes during measurement
Samples inlet tube	The sample inlet tube to the main unit.
Sample outlet tube	The sample outlet tube from the main unit.
SD card slot	Remove the cap to access the SD card slot.
Power cable or communication cable	A cable for power supply connection.

Inside the main unit, printed circuit boards for operation and control, a pump to introduce rinsing water to the main unit, and the sensor to detect the residual chlorine are included. The main unit (excluding the DC jack) has waterproof structure specified by IPX4.

2 Outline

2.3 Description of each part

● Screen

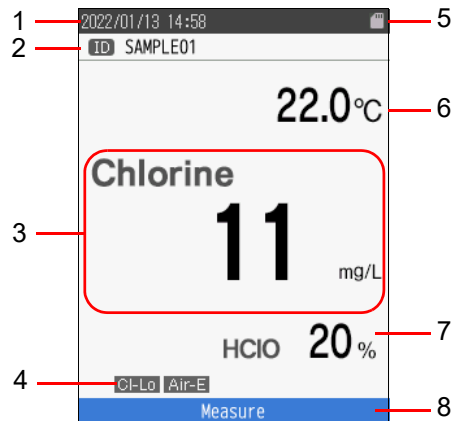

Number	Name	Display content
1	Actual date and time	The current date and time.
2	Device ID	Device ID you have entered.
3	Measurement item	Residual chlorine concentration.
4	Error display	Refer to "8 Errors and countermeasures" (page 50).
5	SD memory card icon	Displayed when SD memory card is inserted into the main unit.
6	Temperature display	Sample temperature.
7	Ratio of chlorine formation	The ratio of HClO and ClO ⁻ . When the residual chlorine concentration is 10 mg/L or lower, "---" is displayed.
8	Status display	When pressing MEAS to start, Measure and Wait are displayed.

● Control key

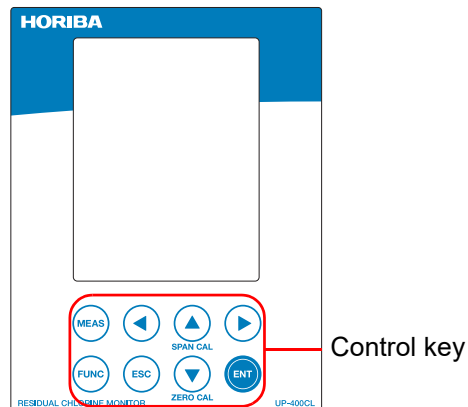



Control key	Name	Main applications
	FUNC key	Switch to the settings screen.
	MEAS key	Start/stop measurement.
	ESC key	Return to the previous screen. Press and hold the key to turn off the screen.
	ENT key	Set values are confirmed in the setting screen. Calibration value is confirmed in the calibration screen.
	UP key	Moves the selection upward in the setting screen. Increases the setting value. Press and hold the key in the measurement screen to display the span calibration screen.
	DOWN key	Moves the selection down in the setting screen. Decreases the setting value. Press and hold the key in the measurement screen to display the zero calibration screen.
	LEFT key	Moves the selection to the left in the setting screen. Press and hold the key in the measurement screen to display the calibration history screen.
	RIGHT key	Moves the selection to the right in the setting screen. Press and hold the key in the measurement screen to display the error history screen.

2 Outline

2.4 Screen description

2.4 Screen description

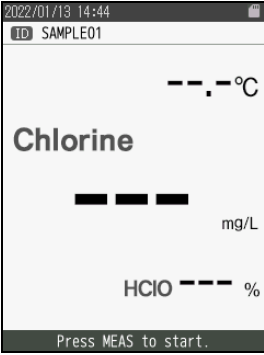
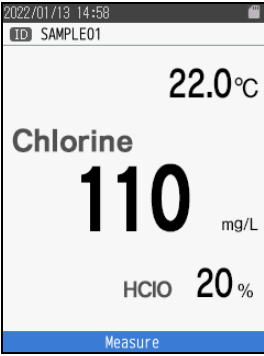
You can switch between screens according to your needs.

Screen	Name	Function
	Standby screen	Displayed after measurement or calibration finishes.
	Measurement screen	Displays the measured value. You can confirm the calibration data. You can confirm the status of the main unit.
	Calibration screen	Zero or span calibration can be operated. The left screen is an example of the span calibration screen.
	Settings screen	You can confirm and change various settings. <ul style="list-style-type: none"> ● Meas. Setting ● Cal. Setting ● Error Setting ● General Setting ● Cal. Result History ● Error History ● Delete History Data

3 Installation

3.1 Installation environment conditions

This product is designed to be used for indoor measurement, such as in factories.

Install the instrument where the following conditions are satisfied.

If the instrument is installed in a place where the installation conditions are not satisfied, warranty will be invalid even if it is within the warranty period.

- Locations where the ambient temperature is between 1°C and 40°C
- Locations where the ambient relative humidity is between 35% and 85%
- Locations where there is no sudden temperature change
- Locations where there is no condensation
- Surface temperature of the instrument is not over 40°C by heat radiation
- A place free from chemicals
- A place free from mechanical vibration
- A place free from the influence of electromagnetic fields
- A place free from dust or corrosive gas
- A place not exposed to direct sunlight
- In addition, locations where the conditions described in "13.2 Specifications" (page 81) are satisfied
- Locations where water can be supplied in compliance with the water supply law

3.2 Confirmation of the contents

Please confirm if the following contents are supplied.

Contents	(i) Standard model UP-400CL-0	(ii) Digital communication model UP-400CL-1-0-*	(iii) Analog communication model UP-400CL-1-1-*
● Main unit	1	1	1
● Communication unit	None	None	1
● Cable	DC jack cable	Communication cable	Communication unit + (Extension cable)
(Cable length)	2 m (Included)	A number indicated in* 1: 1 m 5: 5 m 10: 10 m	A number indicated in* 0: No extension cable 1: 1 m (Extension cable) 5: 5 m (Extension cable) 10: 10 m (Extension cable)
● AC adapter	1	None	None
● Filter	1	1	1
● Tube fitting	1	1	1
● Rubber feet	1 set	1 set	1 set
● External mounting foot (option)	1 set	1 set	1 set
● Pole mount parts (option)	1 set	1 set	1 set

3 Installation

3.3 Installation of the main unit

3.3 Installation of the main unit

The main unit should be installed in either one of the following two directions.

- Install horizontally on the plate so that the screen faces upward

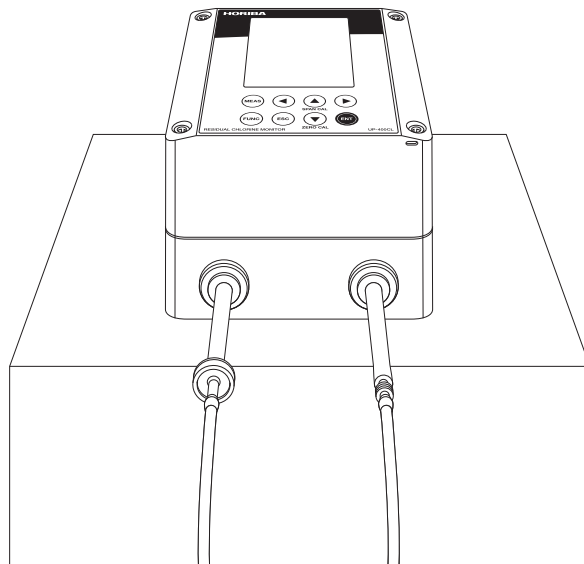

Note	If necessary, attach rubber feet to the main unit. However, color transfer may occur from the rubber feet to the installation surface, and/or the rubber feet may come off if they come into contact with water for a long time.
-------------	--

- Install vertically on the wall so that the pipes face downward
Refer to page 11 for mounting the external mounting feet.

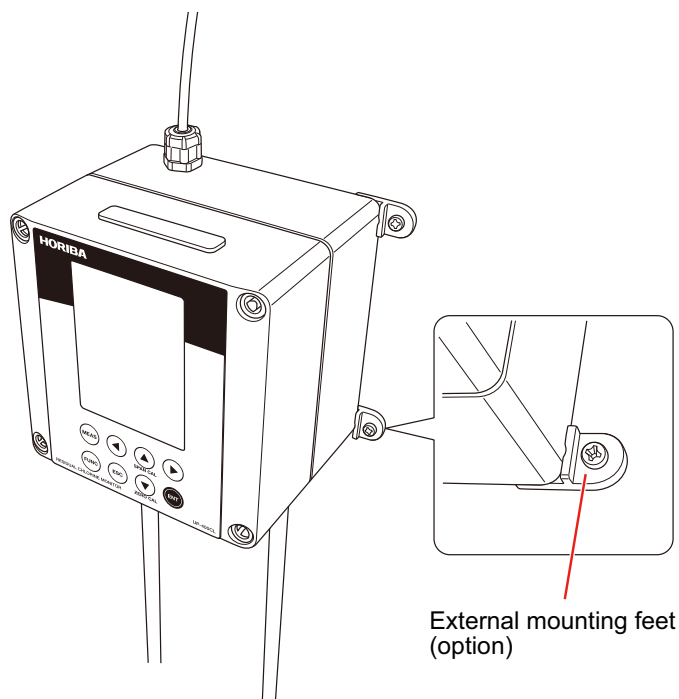

- Install vertically on a pole so that the pipes face downward
Refer to page 11 for installation of pole mount components.

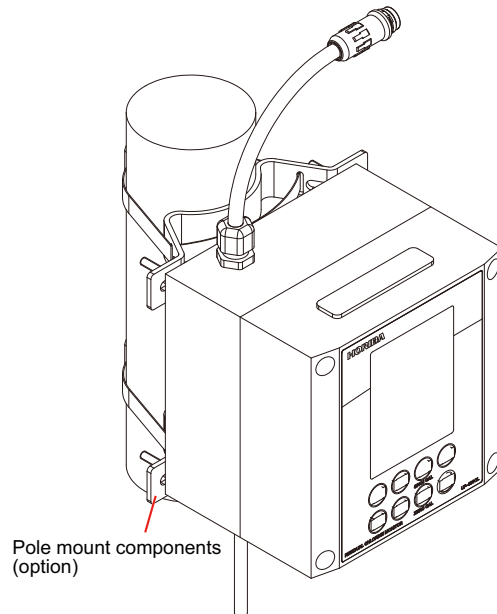

- [Installation of external mounting feet and pole mount components]

Prepare the screw driver.

1. Loosen the four corner screws and open the device cover.

The cable is connected, so open it carefully.

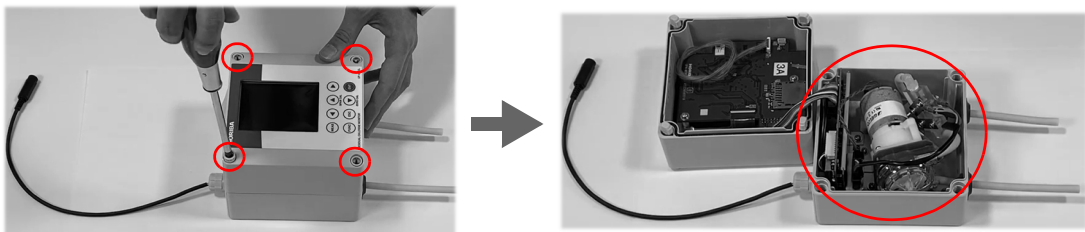

2. Attach the external mounting feet or pole mount components with the attached screws.

(Example of external mounting feet)

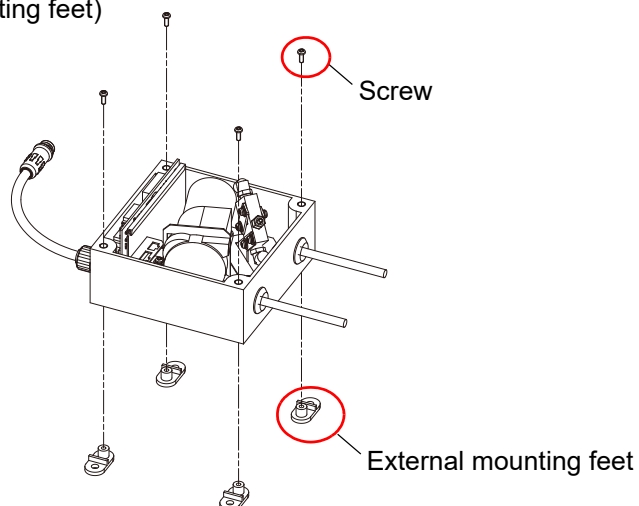

3 Installation

3.4 Tube connection

3.4 Tube connection

Each pipe is fitted with a flexible tube (OD 6.0 mm, ID 3.2 mm).

Please prepare a tube fitting and extension tubes, and connect the extension tubes to the two flexible tubes. Put the inlet into the sample water and the outlet into the drain line.

Attach the filter to the inlet tube when dust might enter the flexible tube during measurement, such as when rinsing vegetables.

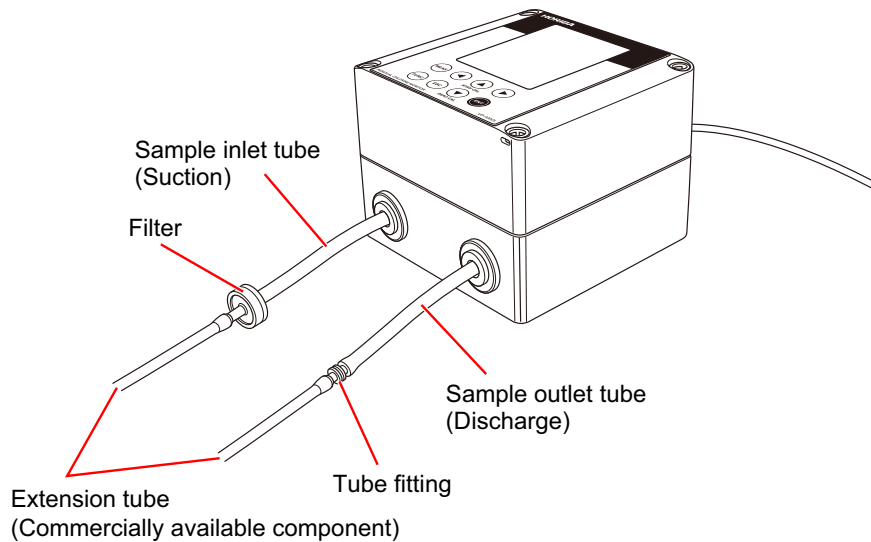

Note	<ul style="list-style-type: none">• If the filter is clogged with dust, replace it with a new filter. Refer to "10.2 List of replacement parts" (page 70) for reference filters.• If the sample outlet tube (Outlet) is closed, the tube may come off inside the device, causing liquid leakage and malfunction. Do not bend or crush the discharge tube or extension tube.
-------------	--

● Example of piping

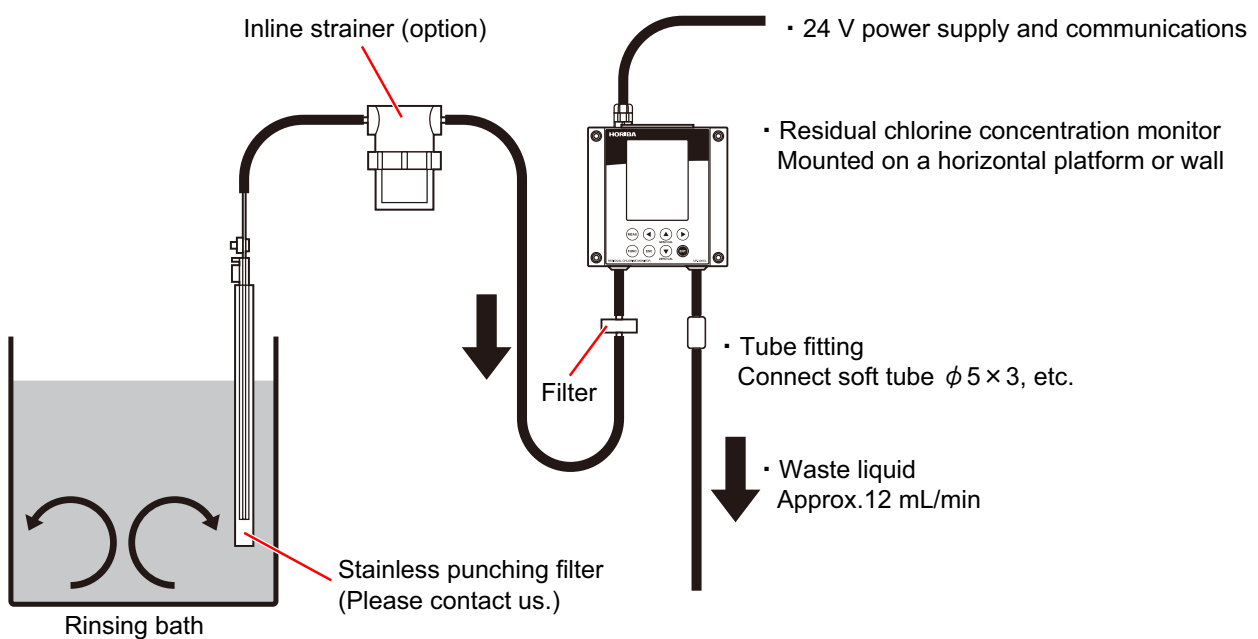

Tip	Keep the tubing from the rinsing bath to the main unit as short as possible. The longer tube will slow down the response.
------------	---

3.5 Power supply

The power supply should be properly connected by a qualified electrician.
The following illustration is just for an image, and the scale is neglected.

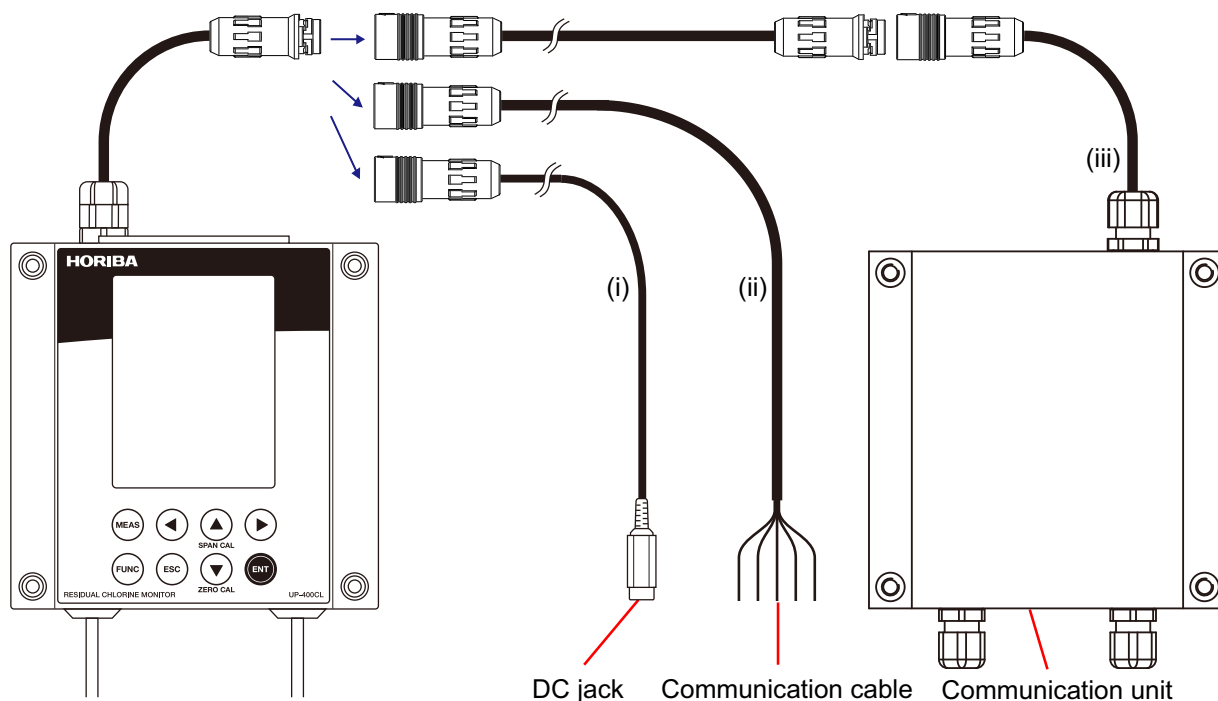

(i) Standard model	For details, refer to "3.5.1 Connection between main unit and AC adapter" (page 14).
(ii) Digital communication model	Refer to "9 Communication and Input/Output specifications" (page 53).
(iii) Analog communication model	Refer to "9 Communication and Input/Output specifications" (page 53).



WARNING



Caution against fire and electric shock

Do not apply excessive force to the cable by repeatedly bending or pulling it, or placing a heavy object on it.

Doing so may cause fire, electric shock, or malfunction.

3 Installation

3.5 Power supply

3.5.1 Connection between main unit and AC adapter

1. Connect the DC output of the AC adapter to the DC jack of the main unit.
2. Connect the plug of the AC adapter to the outlet.
3. Power is supplied.

The main unit has no power switch.

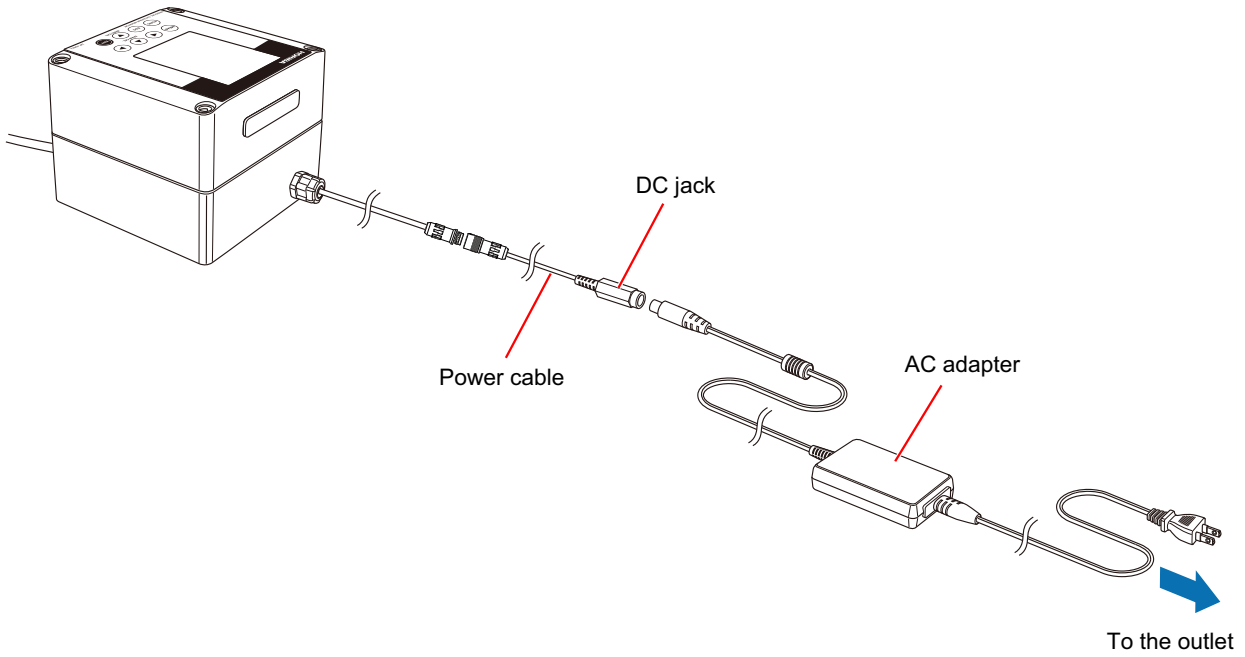



4 Measurement

Dissolved chlorine is measured by means of voltammetry with diamond electrodes. For details, refer to "13.1 Measuring principle" (page 79).

When measurement starts, the sample liquid will be automatically introduced to the main unit, and measurement will continue according to the setting parameters.

Calibration is needed beforehand. For details, refer to "5 Calibration" (page 19).

Note	It may take several hours for the measurement value to be stabilized, just after installation, or when the main unit has not been used for a long time. It may take about an hour for the measurement value to be stabilized when measuring the highly concentrated liquid (over 100 mg/L) just after measuring the liquid with a low concentration of around 0, such as tap water.
-------------	--

		<p>You can also confirm the screen operations in this chapter with a simple video.</p> <p>For the URL, refer to the "Measurement" section in "Watch the operation in the video" (page 83).</p>
---	---	--

4.1 Start/stop

The power to the main unit automatically turns ON when connecting it to the power source. For details, refer to "3.5 Power supply" (page 13).

When the power is turned ON, the standby screen will appear in a few seconds.

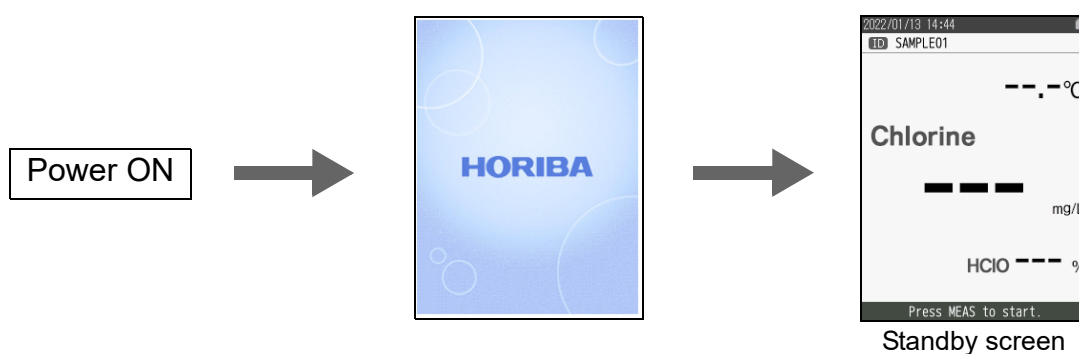

Tip	<p>When turning the power OFF, unplug the AC adapter from the outlet when the standby screen is displayed*.</p> <p>*Press the ESC key on each screen, or press it several times to return to the standby screen.</p> <p>However, if the main unit is connected with a PC or PLC, ask the qualified electrician for the right procedure of shutting down.</p>
------------	--

4 Measurement

4.2 Preparation for measurement

- Set the clock in the setting screen, if the time is not correct.
("6.5.2 Date/Time Setting" (page 37))
The clock is backed up by the inner battery.
- Proceed calibration.
("5.1 Manual Cal." (page 20) or "5.2 Real-time calibration" (page 21))
- Set the parameters for measurement.
("6.2 Meas. Setting" (page 24))
- Enter the device ID (user's equipment name) to identify the data to be saved in the SD card.
("6.5.1 Device ID Setting" (page 36))

4.3 Measurement start and stop

- Press MEAS key during standby mode to start measurement, and the measurement screen will appear.
- If you set "6.2.2 Meas. Interval (min.)" (page 27), the measurement screen during intervals will also be displayed.
- If the operation is controlled by digital communication with a PC or PLC, refer to "Communication and Input/Output specifications" (page 53).

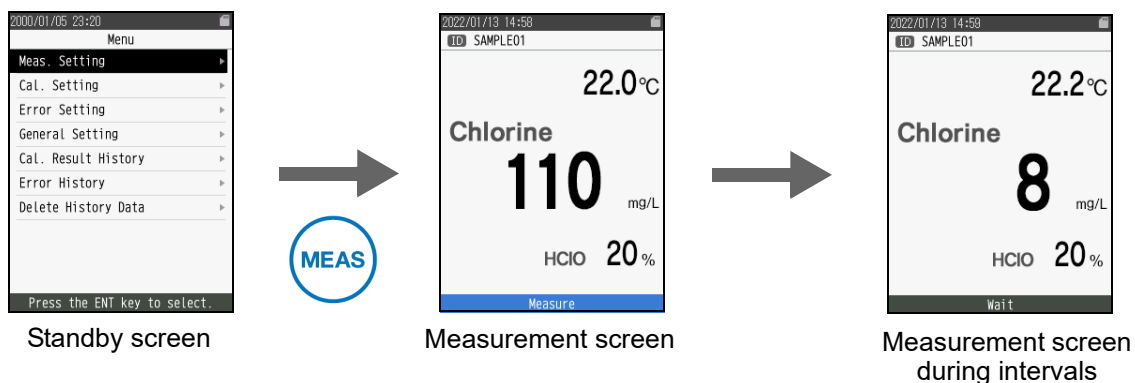

1. Press the MEAS key in the standby screen.
Measurement will start and the measurement screen is displayed.
The calibration screen and history screen can be displayed from the measurement screen. ("Displaying the calibration screen from the measurement screen" (page 17), "Displaying the history screen from the measurement screen" (page 17))
2. Press the MEAS key again during measurement.
Measurement will stop, and the display will return to the standby screen.

4.3.1 Displaying the calibration screen from the measurement screen

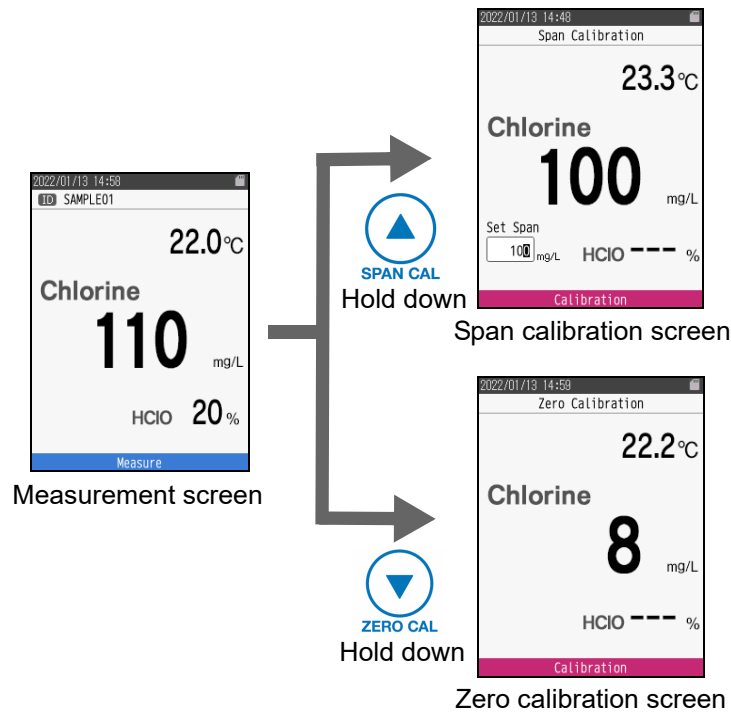

4.3.2 Displaying the history screen from the measurement screen

History screens are displayed while the ◀▶ keys are pressed.

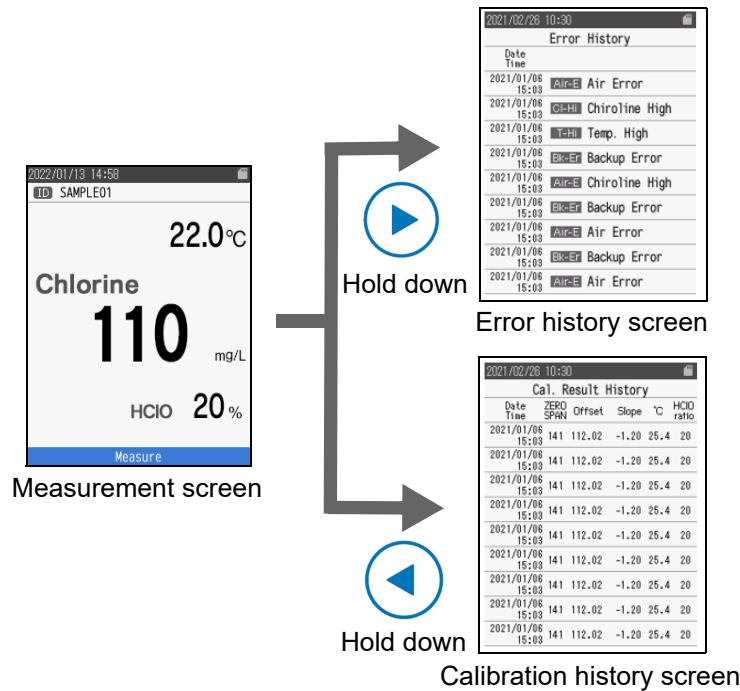

Tip	Calibration history screen and error history screen can also be displayed from the setting menu screen. ("6.6 Cal. Result History" (page 42), "6.7 Error History" (page 43))
-----	--

4 Measurement

4.4 Measurement operation

4.4 Measurement operation

In the default setting, when measurement starts, the sample liquid will be replaced for three seconds, and the measurement value will be updated by measuring the residual chlorine concentration and liquid temperature about every ten seconds.

It is possible to change the number of times for moving average, interval time, and the number of measurement times. For details, refer to "4.2 Preparation for measurement" (page 16).

● Measurement operation

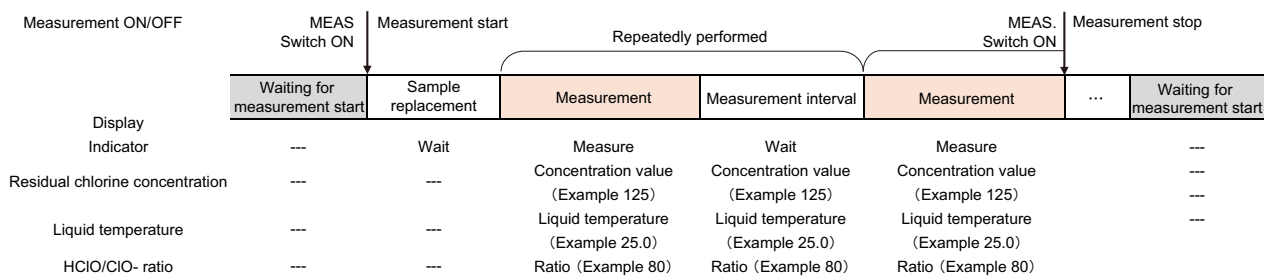

● Measurement operation when moving average is set

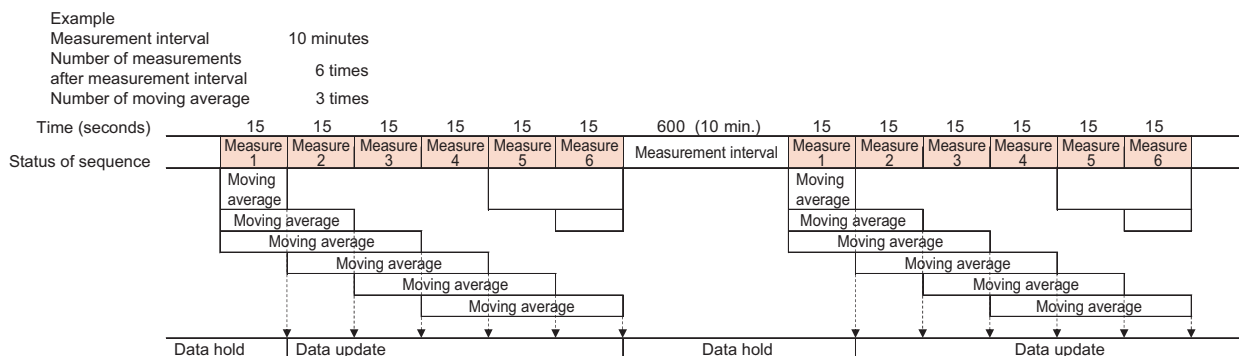

Tip	<p>What is a moving average? One of the statistical methods. This method can be used to show the trend by defining an Interval of a certain period and continuously calculating the AVG within that Interval. (Quoted from Digital daijisen)</p>
------------	--

5 Calibration

Be sure to perform calibration before measurement.

There are two calibration methods.

- Manual Cal.: A method to directly enter the calibration value (page 20)
- Real-time calibration: A method to perform real-time calibration during measurement (page 21)

Tip	To calibrate in real time during measurement, perform a two-point calibration: zero and span calibration. Either zero calibration or span calibration can be performed first. <ul style="list-style-type: none">• Zero calibration: Zero calibration is performed using a sample with almost zero chlorine. (Tap water may be used.)• Span calibration: Span calibration is performed with using a sample with known chlorine concentration.
-----	--

5 Calibration

5.1 Manual Cal.

5.1 Manual Cal.

When you want to return the calibration factor to the previous one directly enter the numerical value and perform calibration.

Item	Content	Settings range	Initial value
Manual Cal.	Enter the slope, offset and temperature for calibration.	Slope: 0.00 to 1000.00	300.00
		Offset: -50.0 to 0.0	-2.00
		Temperature: 0.0 to 99.9	25.0

1. Press the FUNC key on the standby screen.
Setting menu (MENU) screen is displayed.
2. Press the ▲▼ keys to select “Cal. Setting” and press the ENT key.
Calibration setting menu screen is displayed.
3. Press the ▲▼ keys to select “Manual Cal.” and press the ENT key.
The manual calibration selection screen is displayed.
4. Press the ▲▼ keys to select “Slope”, “Offset” or “Sample Temp.” and press the ENT key.
5. Select a digit with the ◀▶ keys and press the ▲▼ keys to set the numerical value.
▲: To increase value
▼: To decrease value

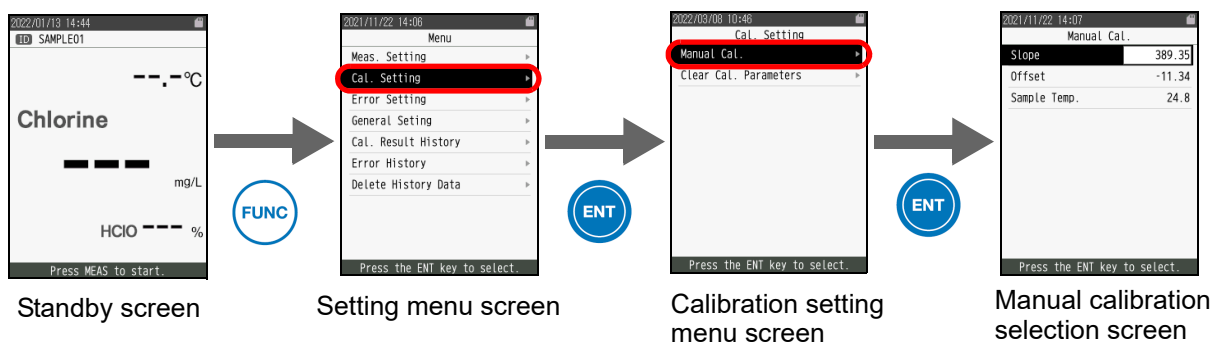

Repeat steps 4. and 5. if necessary.

Tip	Press the ESC key to cancel the set item.
-----	---

5.2 Real-time calibration

Perform zero calibration and span calibration.



5.2.1 Zero calibration

For zero calibration, almost zero chlorine sample is used, such as tap water.

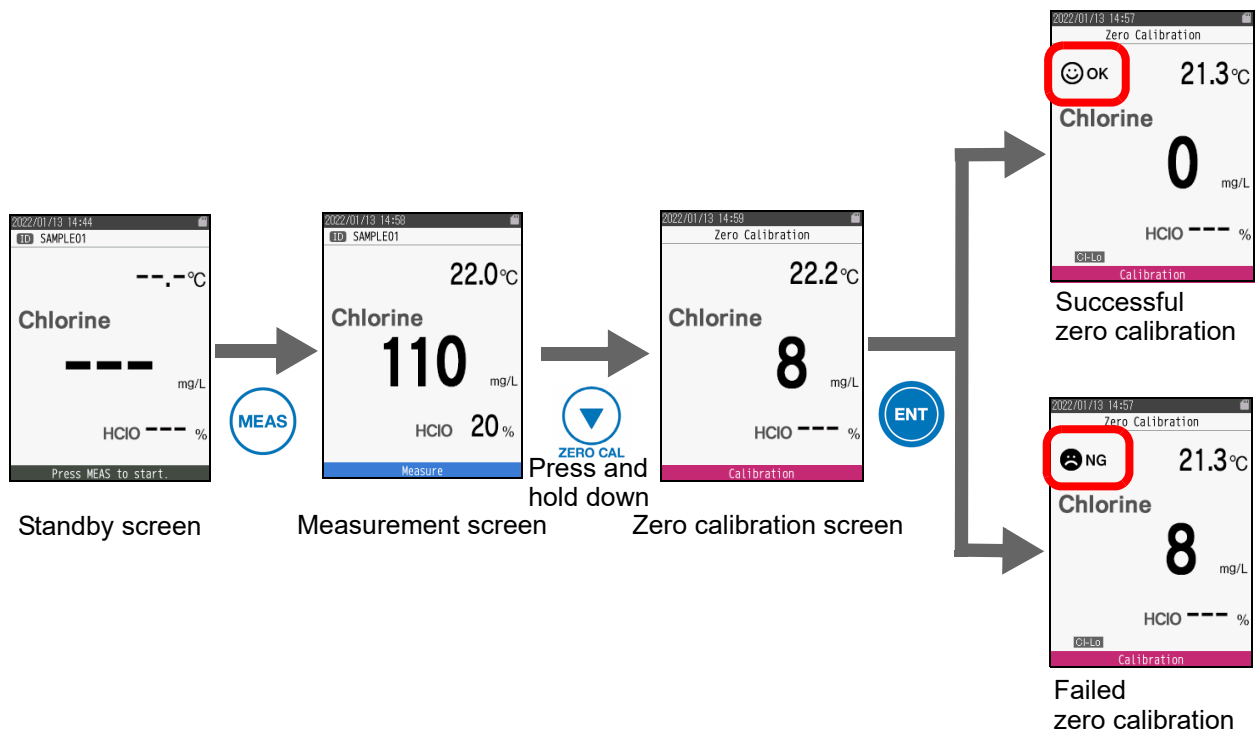
1. Press the MEAS key on the standby screen.
Measurement screen is displayed.
2. When the indication is stable, press and hold down the ▼ key.
Zero calibration screen will appear and the concentration value will blink.
3. When the value become stable, press the ENT key.
The measured value is turned to be "0" by zero calibration.
4. Press the ESC key.
 - OK: The screen is returned to the measurement screen.
 - NG: The screen is returned to the calibration screen. Perform the step 3 again.



Tip	The concentration is calculated to be 0 from the measured electrical current value and the temperature of the sample. The calibration value used at this time is the previous calibration value.
------------	---

		<p>You can also confirm the screen operations in this chapter with a simple video.</p> <p>For the URL, refer to the "Zero calibration" section in "Watch the operation in the video" (page 83).</p>
---	---	---

5 Calibration

5.2 Real-time calibration



5.2.2 Span calibration

Perform calibration using samples with known chlorine concentration.

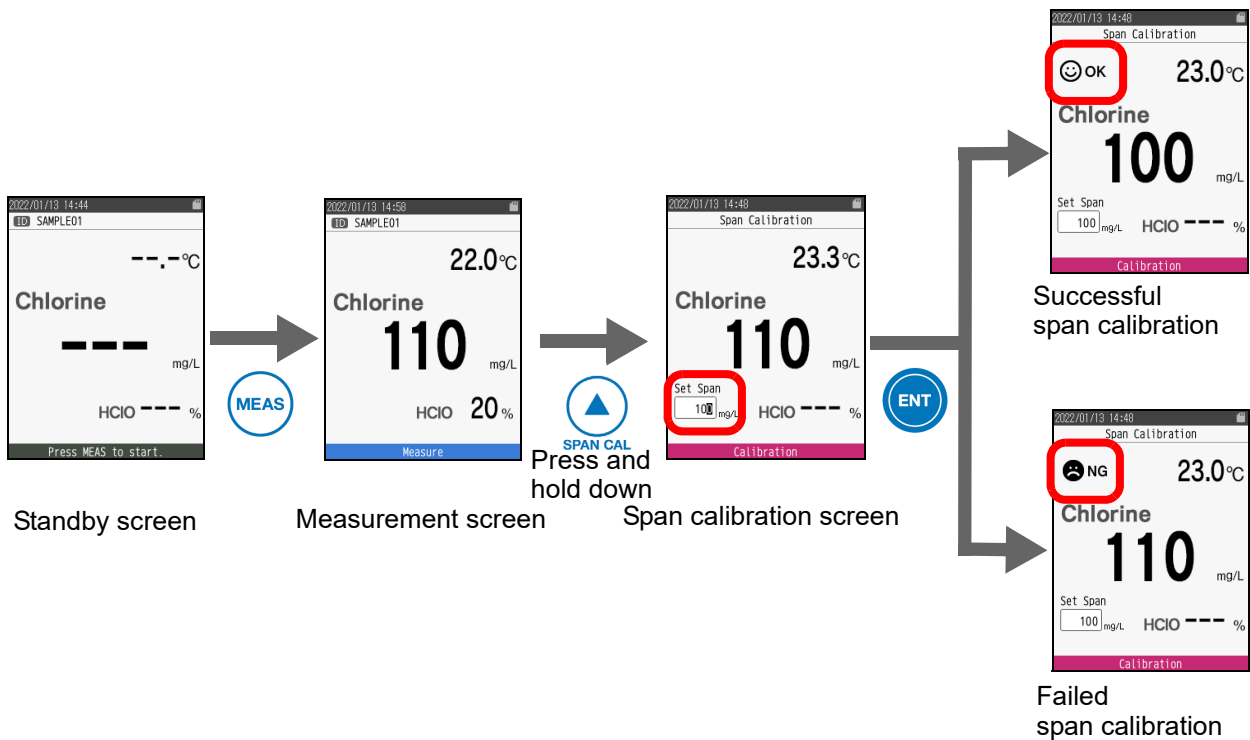
1. Press the MEAS key on the standby screen.
Measurement screen is displayed.
2. When the indication is stable, press and hold down the ▲ key.
The span calibration screen will be displayed.
3. Select the digit by ◀ ▶ keys, increase or decrease the value by ▲ ▼ keys, then input the known chlorine concentration of the sample.
The input value is displayed on the set span.
4. When the value become stable, press the ENT key.
Span calibration starts.
5. Press the ESC key.
 - OK: The screen is returned to the measurement screen.
 - NG: The screen is returned to the calibration screen. Perform the step 3 again.



Tip	The concentration is calculated to become the entered span value from the measured electrical current value and sample temperature.
-----	---

		You can also confirm the screen operations in this chapter with a simple video. For the URL, refer to the "Span calibration" section in "Watch the operation in the video" (page 83).
---	---	--

6 Settings (Menu)

- You can confirm or change each setting by pressing the FUNC key.
- You can also operate with communications ("Communication and Input/Output specifications" (page 53)).

6.1 Settings item list

First category		Reference page
	Second category	
Meas. Setting		24
	Mode Select	25
	Meas. Interval (min.)	27
	Meas. Times after Int.	28
	Number of Moving Ave.	29
	HCIO or CIO-ratio	30
Cal. Setting		31
	Manual Cal.	31
	Clear Cal. Parameters	31
Error Setting		32
	Low Chlorine Error	32
	High Chlorine Error	33
	Low Temp. Error	34
	High Temp. Error	35
General Setting		36
	Device ID Setting	36
	Date/Time Setting	37
	Brightness	38
	Factory Reset	39
	Pump Reset	40
	QR code of Instructions	41
Cal. Result History		42
Error History		43
Delete History Data		44
	Delete the error history (Error History)	44
	Delete the calibration result (Cal. Result History)	45

6 Settings (Menu)

6.2 Meas. Setting

Measurement conditions such as the interval time setting for intermittent measurement, or the measurement times after restart from the interval (waiting) can be configured.

Second category	Content	Settings range	Initial value	Reference page
Mode Select	The measuring method of chlorine is selected according to the characteristics of sample water taking pH or vegetable to be included into account.	<ul style="list-style-type: none">● Red● Oxd● Redox● Vegetable	Redox	25
Meas. Interval (min.)	The waiting time for the intermittent measurement is set by the interval.	0 to 30000	0	27
Meas. Times after Int.	Number of measurement times is set by this mode.	1 to 30000	3	28
Number of Moving Ave.	The number of moving average can be set by this mode.	1 to 240	1	29
HClO or ClO ⁻ -ratio	Select the formation of chlorine in water from HClO or ClO ⁻ for the ratio presentation.	<ul style="list-style-type: none">● HClO● ClO⁻	HClO	30

6.2.1 Mode Select

Select the measurement mode of residual chlorine measuring process. Output concentration is calculated from the current to be measured in each measurement mode.

Refer to the following table, and select the measurement mode.

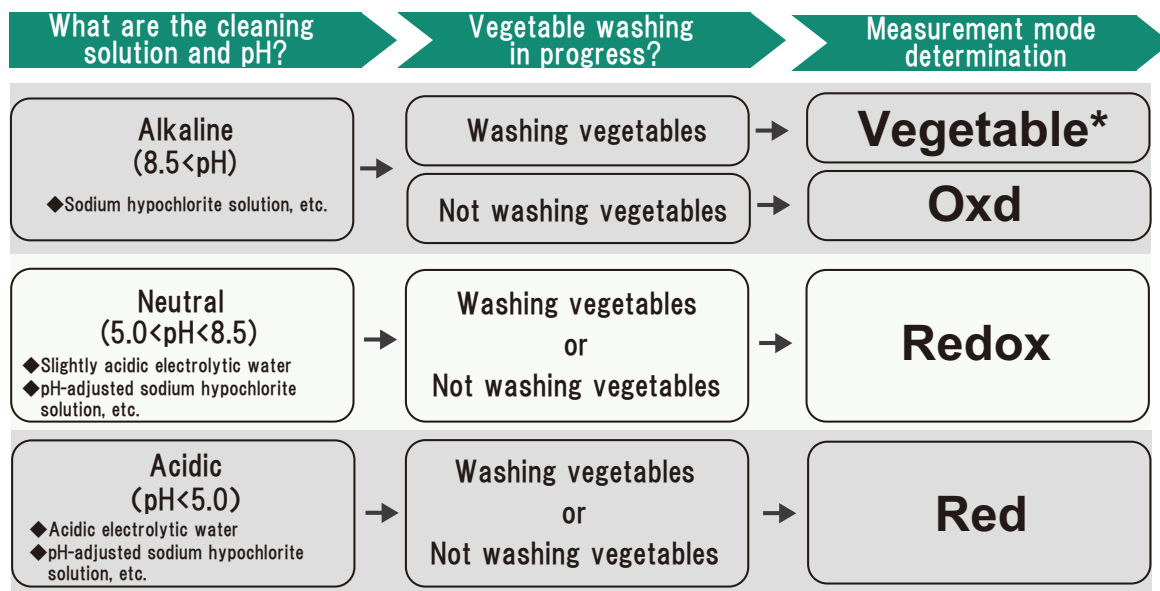

*The ratio of hypochlorous acid or hypochlorite ion is displayed.
This mode takes a few seconds longer for measurement than other modes.

Tip	Select the "Red" mode if the pH is controlled by citric acid.
------------	---

Note	If the pH of sample water is controlled by carbon dioxide (Hypochlorous acid carbonated), the measured value will become unstable, and accurate result could not be expected. For more information, please contact us.
-------------	--

- Press the FUNC key on the standby screen.
Setting menu (MENU) screen is displayed.
- Press the ▲▼ keys to select "Meas. Setting" and press the ENT key.
Measurement setting menu screen is displayed.
- Press the ▲▼ keys to select "Mode Select" and press the ENT key.
Measuring mode settings screen is displayed.
- Press the ▲▼ keys to select the measurement mode.
 - Red: The reduction current is measured by applying a negative voltage to the working electrode.
 - Oxd: The oxidation current is measured by applying a positive voltage to the working electrode.
 - Redox: Both reduction and oxidation currents are measured by applying negative and positive voltage to the working electrode.
 - Vegetable: Both reduction and oxidation currents are measured by applying negative and positive voltage to the working electrode during vegetable washing.

6 Settings (Menu)

6.2 Meas. Setting

5. Press the ENT key to select the measurement mode.

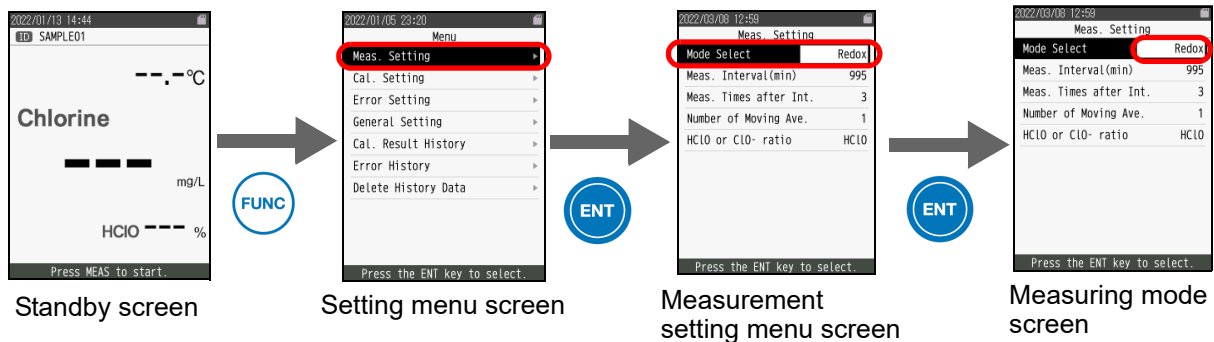

Tip	<ul style="list-style-type: none">• When the measurement mode is changed, calibration parameter clear screen is displayed. ("6.3.2 Clear Cal. Parameters" (page 31))• Press the ESC key to cancel the selected item.
-----	---

6.2.2 Meas. Interval (min.)

Set the waiting time for the intermittent measurement.

"Wait" is displayed while the device pauses.

Set it to 0 for continuous measurement without intervals.

1. Press the FUNC key on the standby screen.

Setting menu (MENU) screen is displayed.

2. Press the ▲▼ keys to select "Meas. Setting" and press the ENT key.

Measurement setting menu screen is displayed.

3. Press the ▲▼ keys to select "Meas. Interval (min)" and press the ENT key.

The measurement interval setting screen is displayed.

4. Select a digit with the ◀▶ keys and press the ▲▼ keys to set the measurement interval time.

▲: To increase value

▼: To decrease value

Settings range: 0 to 30000 minutes

5. Press the ENT key to confirm the settings.

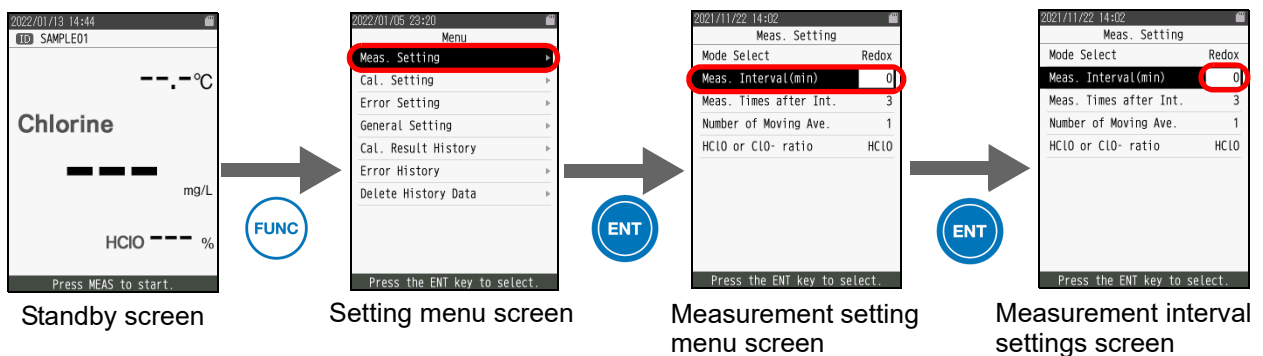

Tip

Press the ESC key to cancel the selected item.

6 Settings (Menu)

6.2 Meas. Setting

6.2.3 Meas. Times after Int.

Set the number of measurement times for intermittent measurement.

The measuring period will be calculated by about 15 seconds × number of measurement times.

It takes about 15 seconds for one measurement.

1. Press the FUNC key on the standby screen.

Setting menu (MENU) screen is displayed.

2. Press the ▲▼ keys to select “Meas. Setting” and press the ENT key.

Measurement setting menu screen is displayed.

3. Press the ▲▼ keys to select “Meas. Times after Int.” and press the ENT key.

The setting screen for the number of measurements after measurement interval will be displayed.

4. Select a digit with the ◀▶ keys and press the ▲▼ keys to set the number of measurements after the measurement interval.

▲: To increase value

▼: To decrease value

Settings range: 0 to 30000 times

5. Press the ENT key to confirm the settings.

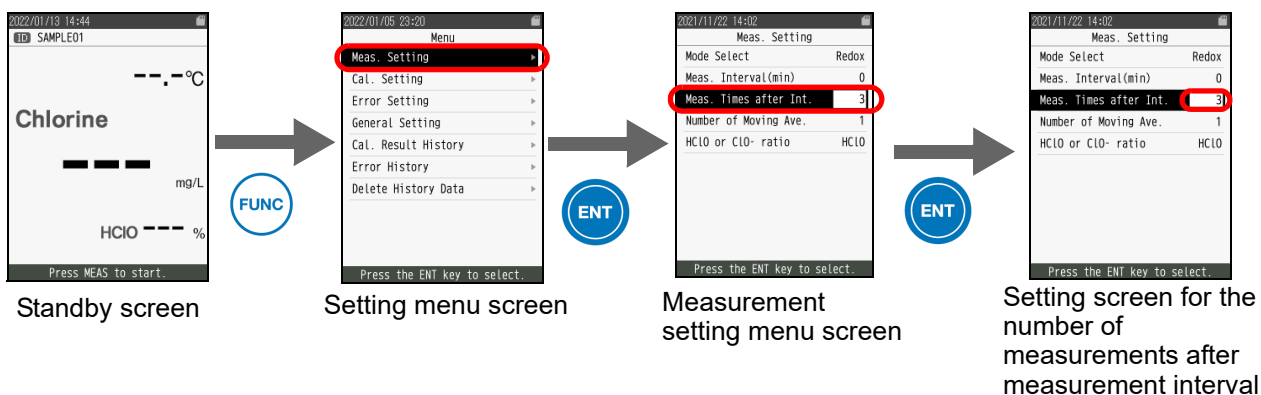

Tip	Press the ESC key to cancel the selected item.
-----	--

6.2.4 Number of Moving Ave.

Set the number of times to perform moving average when performing moving average on the measurement data.

1. Press the FUNC keys on the standby screen.

Setting menu (MENU) screen is displayed.

2. Press the ▲▼ keys to select “Meas. Setting” and press the ENT key.

Measurement setting menu screen is displayed.

3. Press the ▲▼ keys to select “Number of Moving Ave.” and press the ENT key.

The setting screen for the number of times to perform moving average is displayed.

4. Select a digit with the ◀▶ keys and press the ▲▼ keys to set the number of times to perform moving average.

▲: To increase value

▼: To decrease value

Settings range: 1 to 240 times

5. Press the ENT key to confirm the settings.

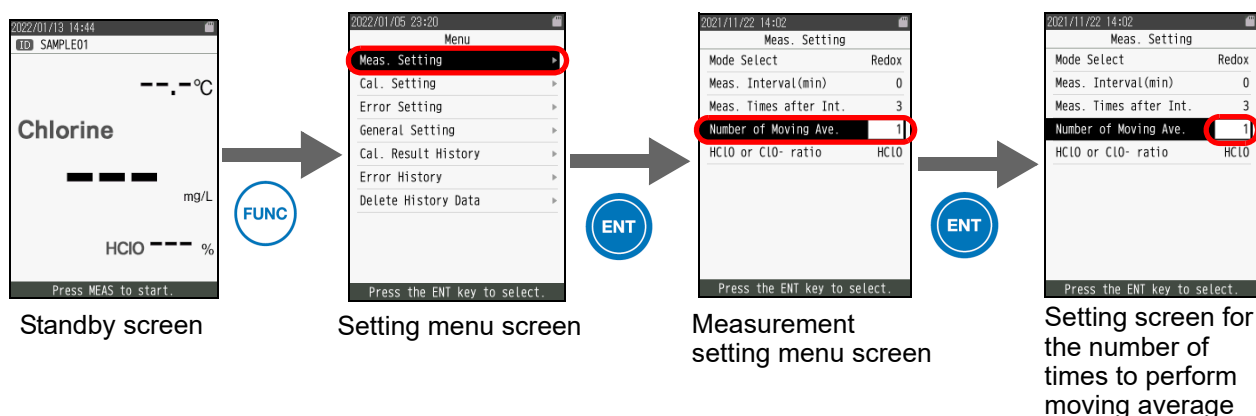

Tip

Press the ESC key to cancel the selected item.

6 Settings (Menu)

6.2 Meas. Setting

6.2.5 HClO or ClO⁻ratio

Set whether to display the percentage of HClO or ClO⁻.

1. Press the FUNC key on the standby screen.
Setting menu (MENU) screen is displayed.
2. Press the ▲▼ keys to select “Meas. Setting” and press the ENT key.
Measurement setting menu screen is displayed.
3. Press the ▲▼ keys to select “HClO or ClO⁻ ratio”, and press the ENT key.
The settings screen for switching the existence ratio display is displayed.
4. Press the ▲▼ keys to set the existence ratio display to settings.
 - HClO: Hypochlorous acid
 - ClO⁻: Hypochlorite ion
5. Press the ENT key to confirm the settings.

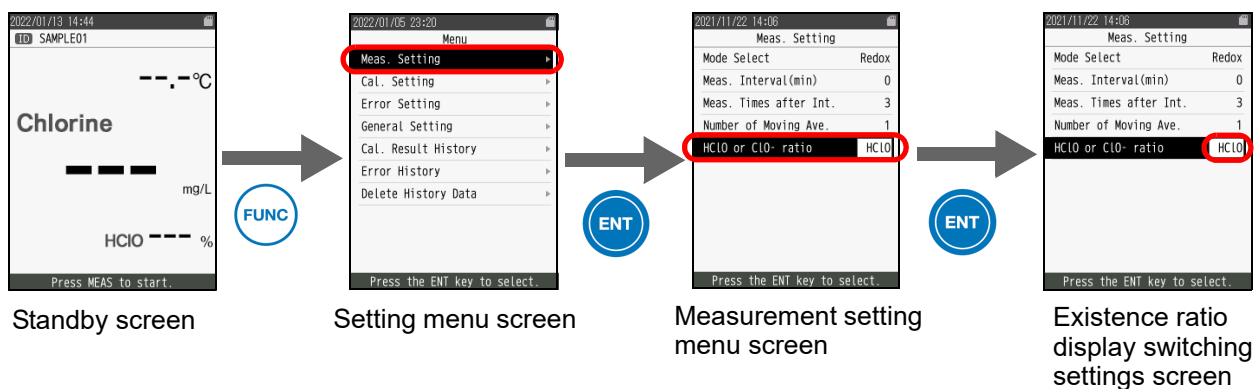

Tip

Press the ESC key to cancel the selected item.

6.3 Cal. Setting

You can clear the calibration factor.

In addition to zero calibration and span calibration, you can enter a calibration value directly for calibration.

Item	Content	Settings range	Default setting
Clear Cal. Parameters	Clear calibration factor.	Cancel, OK	OK

6.3.1 Manual Cal.

Enter the numerical value directly to perform manual calibration.

For the settings method, refer to "5.1 Manual Cal." (page 20).

6.3.2 Clear Cal. Parameters

Clear calibration factor.

When you change the measurement mode, the calibration factor clear screen is automatically displayed.

1. Press the FUNC key on the standby screen.
Setting menu (MENU) screen is displayed.
2. Press the ▲▼ keys to select "Cal. Setting" and press the ENT key.
Calibration setting menu screen is displayed.
3. Press the ▲▼ keys to select "Clear Cal. Parameters" and press the ENT key.
The screen to clear calibration factor is displayed.
4. Press the ◀▶ keys to select OK and press the ENT key to clear the calibration parameters.

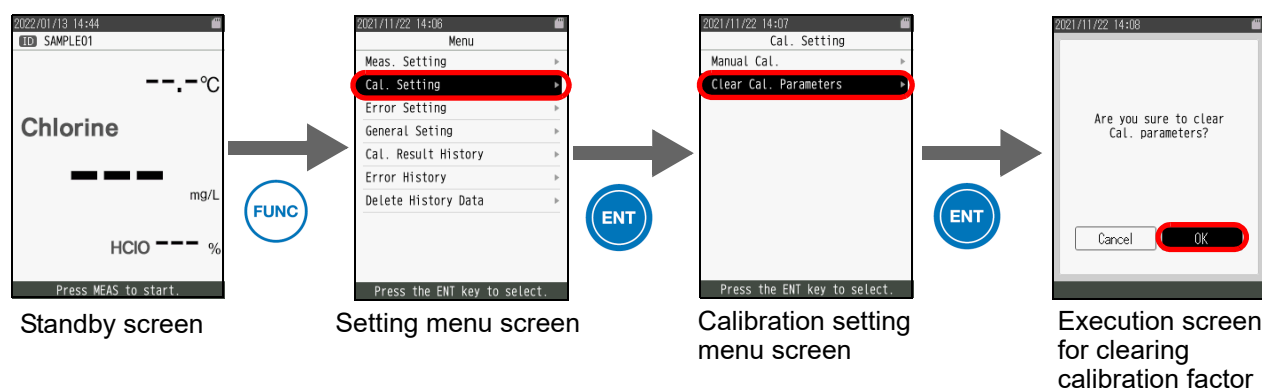

Tip	Pressing the ESC key cancels erasing the calibration parameters.
-----	--

6 Settings (Menu)

6.4 Error Setting

6.4 Error Setting

If the upper or lower limit for concentration or temperature is set, an error will be output when the data exceeds the limit.

Item	Content	Settings range	Initial value	Reference page
Low Chlorine Error	Set the lower limit of the concentration value to output an error.	0 to 999	10	32
High Chlorine Error	Set the upper limit of the concentration value to output an error.	0 to 999	100	33
Low Temp. Error	Set the lower limit of the temperature value to output an error.	0.0 to 30.0	5.0	34
High Temp. Error	Set the upper limit of the temperature value to output an error.	10.0 to 99.9	40.0	35

6.4.1 Low Chlorine Error

Set the lower limit of the concentration value to output an error.

1. Press the FUNC key on the standby screen.
Setting menu (MENU) screen is displayed.
2. Press the ▲▼ keys to select “Error Setting” and press the ENT key.
Error setting menu screen is displayed.
3. Press the ▲▼ keys to select “Low Chlorine Error” and press the ENT key.
The settings screen for low concentration error is displayed.
4. Select a digit with the ◀▶ keys and press the ▲▼ keys to set the lower limit of concentration.
▲: To increase value
▼: To decrease value
Settings range: 0 mg/L to 999 mg/L
5. Press the ENT key to confirm the settings.

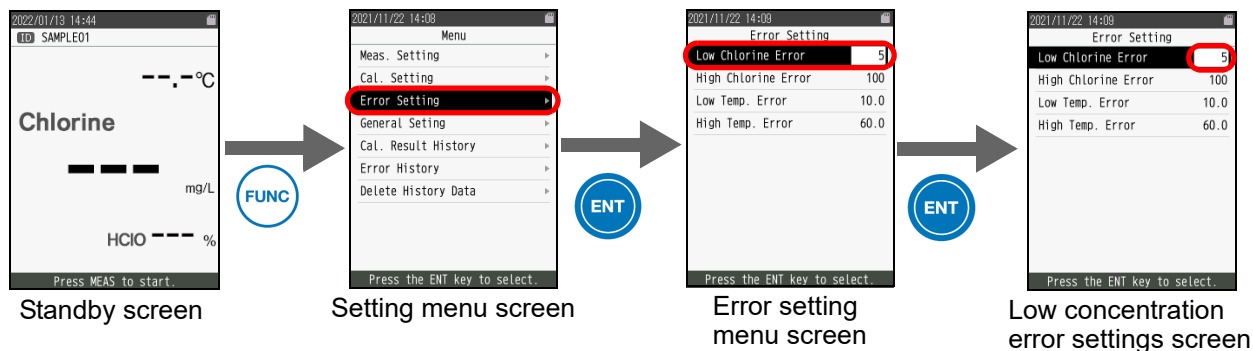

Tip

Press the ESC key to cancel the selected item.

6.4.2 High Chlorine Error

Set the upper limit of the concentration value to output an error.

1. Press the FUNC key on the standby screen.
Setting menu (MENU) screen is displayed.
2. Press the ▲▼ keys to select “Error Setting” and press the ENT key.
Error setting menu screen is displayed.
3. Press the ▲▼ keys to select “High Chlorine Error” and press the ENT key.
The settings screen for high concentration error is displayed.
4. Select a digit with the ◀▶ keys and press the ▲▼ keys to set the upper limit of concentration.
▲: To increase value
▼: To decrease value
Settings range: 0 mg/L to 999 mg/L
5. Press the ENT key to confirm the settings.

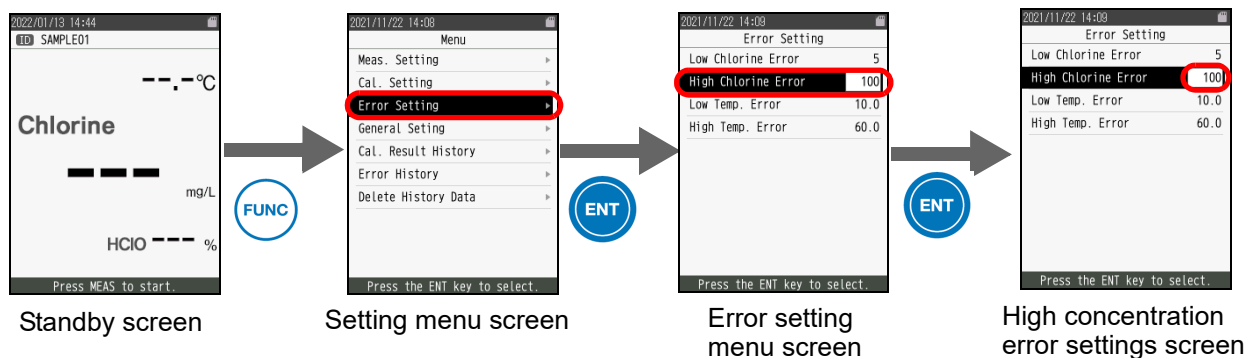

Tip	Press the ESC key to cancel the selected item.
-----	--

6 Settings (Menu)

6.4 Error Setting

6.4.3 Low Temp. Error

Set the lower limit of the temperature value to output an error.

1. Press the FUNC key on the standby screen.
Setting menu (MENU) screen is displayed.
2. Press the ▲▼ keys to select “Error Setting” and press the ENT key.
Error setting menu screen is displayed.
3. Press the ▲▼ keys to select “Low Temp. Error” and press the ENT key.
The settings screen for low temperature error is displayed.
4. Select a digit with the ◀▶ keys and press the ▲▼ keys to set the lower limit of temperature.
▲ : To increase value
▼ : To decrease value
Settings range: 0.0°C to 30.0°C
5. Press the ENT key to confirm the settings.

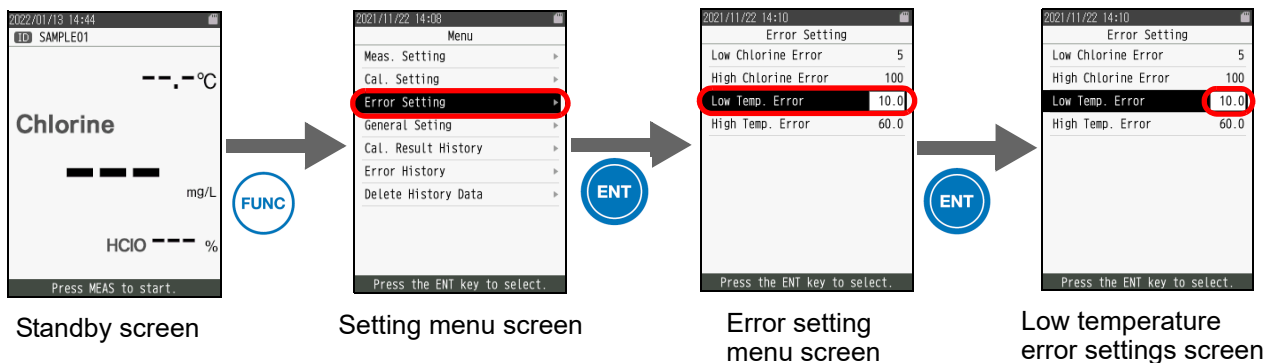

Tip	Press the ESC key to cancel the selected item.
-----	--

6.4.4 High Temp. Error

Set the upper limit of the temperature value to output an error.

1. Press the FUNC key on the standby screen.
Setting menu (MENU) screen is displayed.
2. Press the ▲▼ keys to select “Error Setting” and press the ENT key.
Error setting menu screen is displayed.
3. Press the ▲▼ keys to select “High Temp. Error” and press the ENT key.
The settings screen for high temperature error is displayed.
4. Select a digit with the ◀▶ keys and press the ▲▼ keys to set the upper temperature limit.
▲: To increase value
▼: To decrease value
Settings range: 10.0°C to 99.9°C
5. Press the ENT key to confirm the settings.

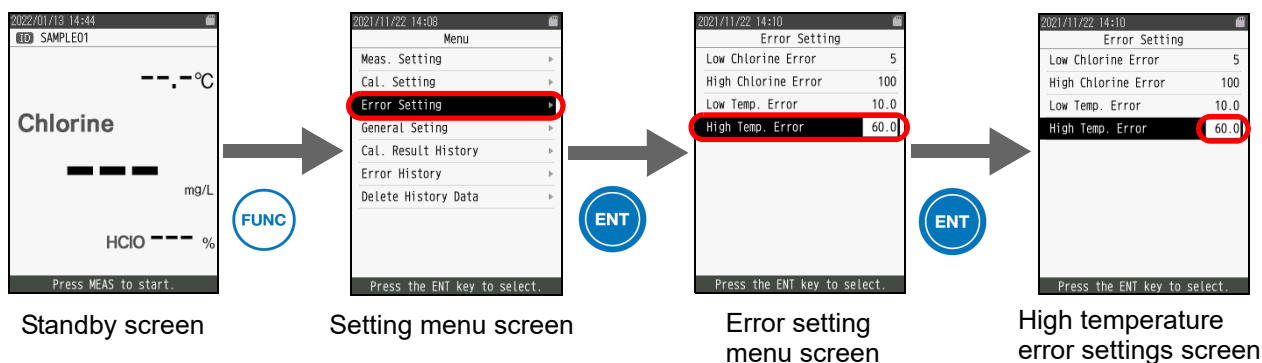

Tip	Press the ESC key to cancel the selected item.
------------	--

6 Settings (Menu)

6.5 General Setting

6.5 General Setting

General items such as settings the ID of the device name of the rinsing bath to be monitored, or clock time setting can be done.

Item	Content	Settings range	Initial value	Reference page
Device ID Setting	Input the user's ID being monitored.	alphanumeric up to 8 characters	-	36
Date/Time Setting	Set the actual date and time in 24 hour display.	Until 23:59 on December 31, 2050	April 1, 2022 00:00	37
Brightness	Select the screen backlight.	1 to 10	-	38
Factory Reset	Reset all settings to the factory default value (initial value).	-	-	39
Pump Reset	Reset the uptime of the pump built into this unit.	-	-	40
QR code of Instructions	Displays a QR code.	-	-	41

6.5.1 Device ID Setting

Input the ID of the user's device to be monitored.

You can input up to 8 characters including capital letters, numerical character, comma, and underscore. It may be useful to read the saved data in the SD card.

1. Press the FUNC key on the standby screen.

Setting menu (MENU) screen is displayed.

2. Press the ▲▼ keys to select "General Setting" and press the ENT key.

The general setting menu screen is displayed.

3. Press the ▲▼ keys to select "Device ID Setting" then press the ENT key.

An alphanumeric input screen is displayed.

4. Press the ▲▼◀▶ keys to select a character and press the ENT key, then select the next character and so on.

- BS: Select BS and press ENT key to clear the newest input character.
- SPACE: Select SPACE and press ENT key to input blank.

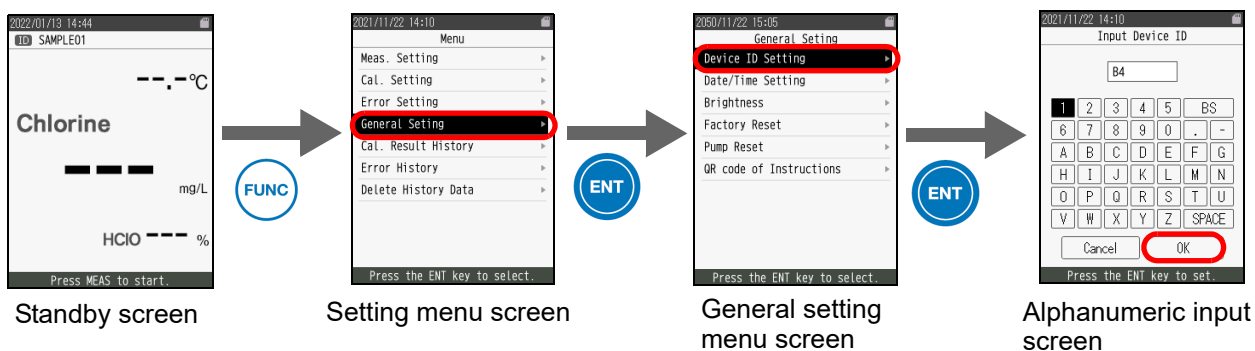

5. Use the ▲▼◀▶ keys to select OK and press the ENT key to confirm the setting.

Tip	Press the ESC key to cancel the selected item.
-----	--

6.5.2 Date/Time Setting

Set the current date and time.

1. Press the FUNC key on the standby screen.
Setting menu (MENU) screen is displayed.
2. Press the ▲▼ keys to select “General Setting” and press the ENT key.
The general setting menu screen is displayed.
3. Press the ▲▼ keys to select “Date/Time Setting” and press the ENT key.
The time settings screen is displayed.
4. Use the ◀▶ keys to select the year, month, hour or minute, and press the ▲▼ keys to set the numerical value.
▲: To increase value
▼: To decrease value

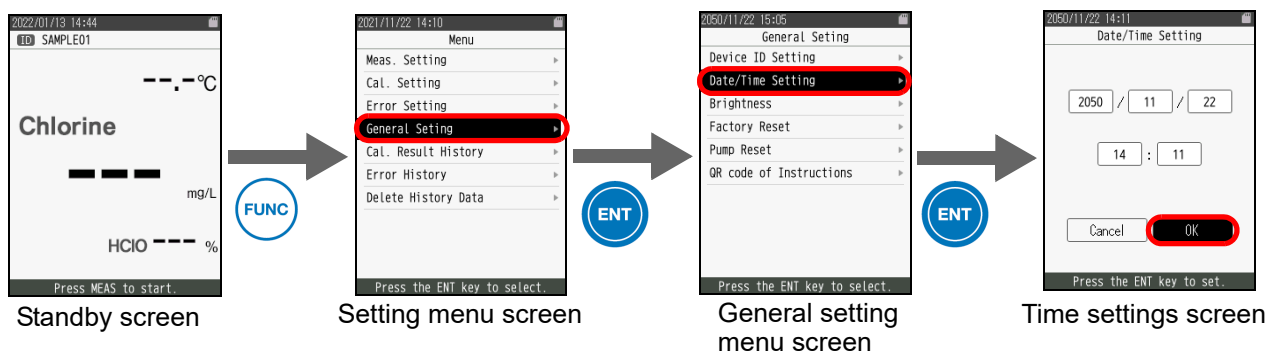

5. Use the ▲▼◀▶ keys to select OK and press the ENT key to confirm the setting.

Tip	Press the ESC key to cancel the selected item.
-----	--

6 Settings (Menu)

6.5 General Setting

6.5.3 Brightness

Adjust the LCD brightness of the screen.

1. Press the FUNC key on the standby screen.
Setting menu (MENU) screen is displayed.
2. Press the ▲▼ keys to select “General Setting” and press the ENT key.
The general setting menu screen is displayed.
3. Press the ▲▼ keys to select “Brightness” and press the ENT key.
The brightness level settings screen will be displayed.
4. Press the ▲▼ keys to set the number value to settings.
▲: To increase value
▼: To decrease value
5. Use the ▲▼◀▶ keys to select OK and press the ENT key to confirm the setting.

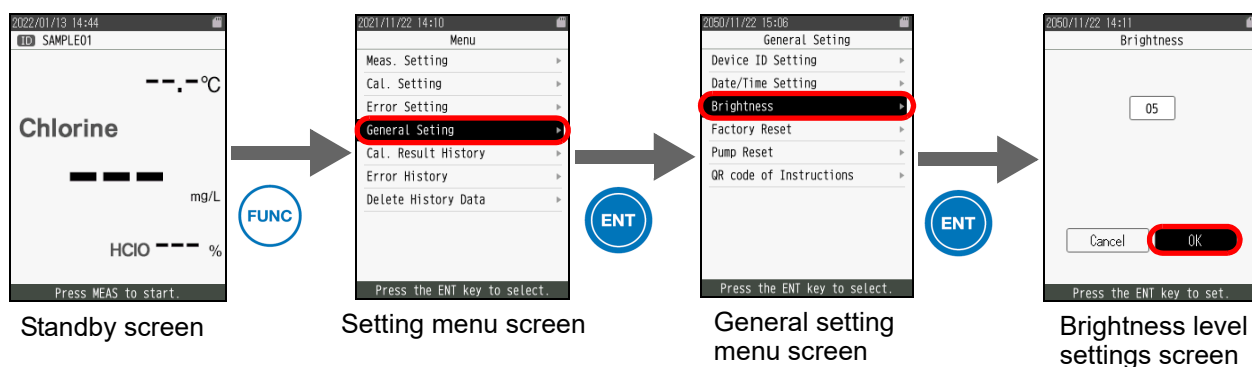

Tip

- Press the ESC key to cancel the selected item.
- Press and hold down the ESC key to turn off the backlight. Measurement continues even if the light turns off during measurement. The backlight will be turned on when any key is pressed.

6.5.4 Factory Reset

Reset all settings to the factory default value (initial value).

1. Press the FUNC key on the standby screen.
Setting menu (MENU) screen is displayed.
2. Press the ▲▼ keys to select “General Setting” and press the ENT key.
The general setting menu screen is displayed.
3. Press the ▲▼ keys to select “Factory Reset” and press the ENT key.
The confirmation screen to reset to the factory default will be displayed.
4. Use the ▲▼ keys to select OK and press the ENT key to confirm the setting.

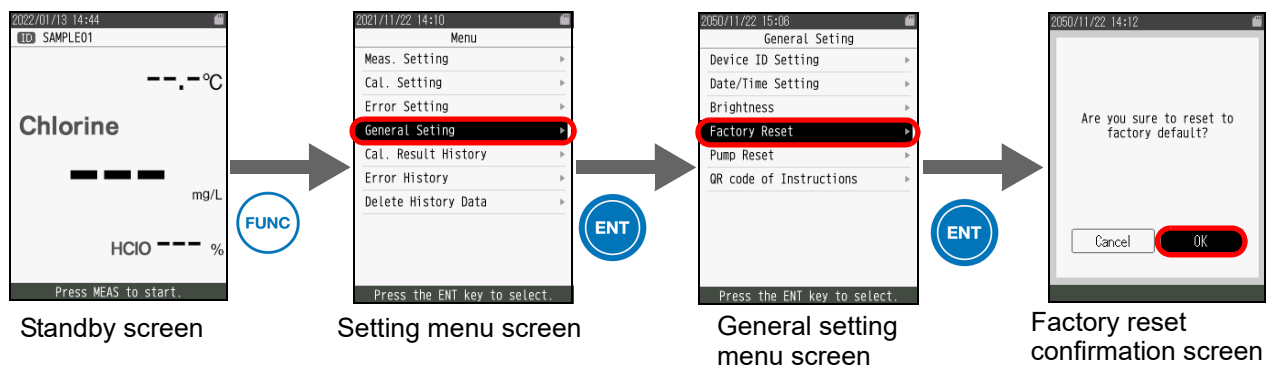

Tip	Press the ESC key to cancel the selected item.
-----	--

6 Settings (Menu)

6.5 General Setting

6.5.5 Pump Reset

Reset the total operating hours of inner pump during measurement to zero.

1. Press the **FUNC** key on the standby screen.
Setting menu (MENU) screen is displayed.
2. Press the **▲▼** keys to select “General Setting” and press the **ENT** key.
The general setting menu screen is displayed.
3. Press the **▲▼** keys to select “Pump Reset” and press the **ENT** key.
Pump reset screen will be displayed.
4. Use the **▲▼** keys to select **OK** and press the **ENT** key to confirm the setting.

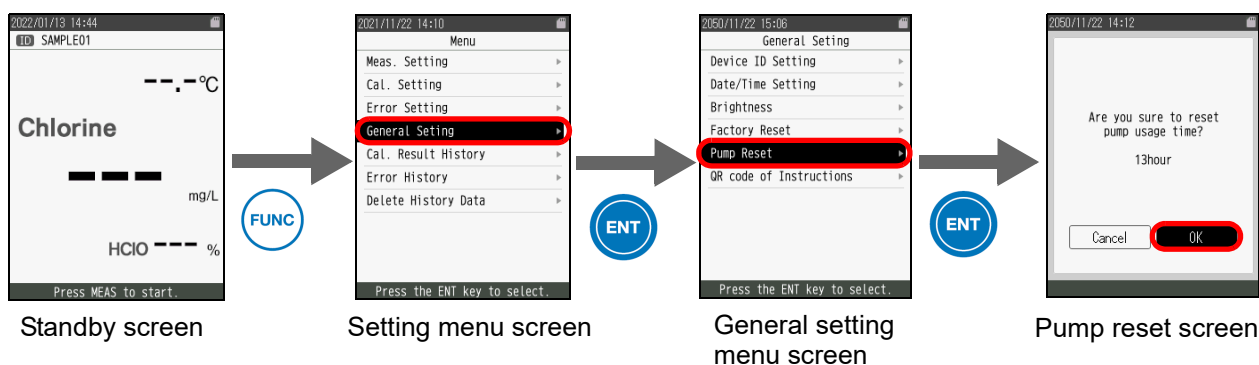

Tip	Press the ESC key to cancel the selected item.
------------	--

6.5.6 QR code of Instructions

Display the QR code. By reading the QR code, you can refer to the instruction manual and video.

1. Press the FUNC key on the standby screen.

Setting menu (MENU) screen is displayed.

2. Press the ▲▼ keys to select “General Setting” and press the ENT key.

The general setting menu screen is displayed.

3. Press the ▲▼ key to select “QR code of Instructions”, and press the ENT key.

The QR code screen will be displayed.

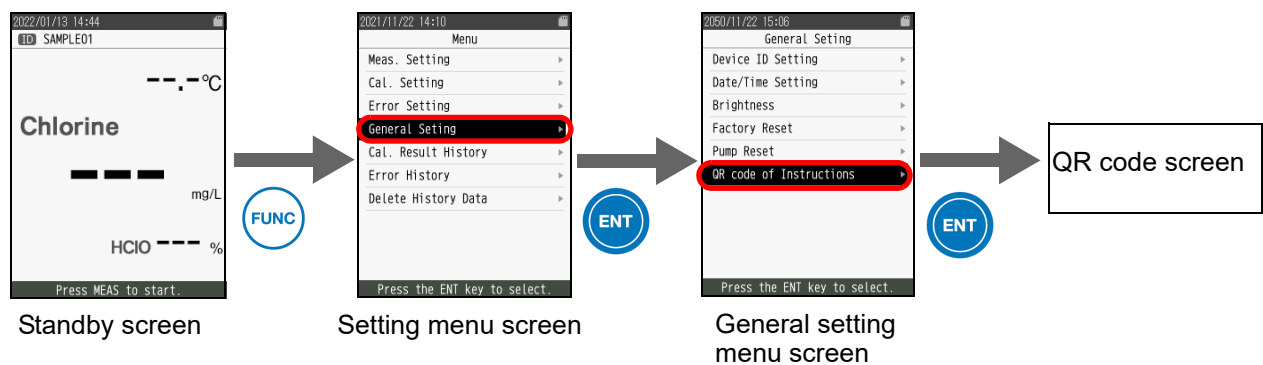

Tip	Press the ESC key to cancel the selected item.
-----	--

6 Settings (Menu)

6.6 Cal. Result History

6.6 Cal. Result History



You can check the latest nine 9 calibration results.

1. Press the FUNC key on the standby screen.
Setting menu (MENU) screen is displayed.
2. Press the ▲▼ keys to select “Cal. Result History” then press the ENT key.

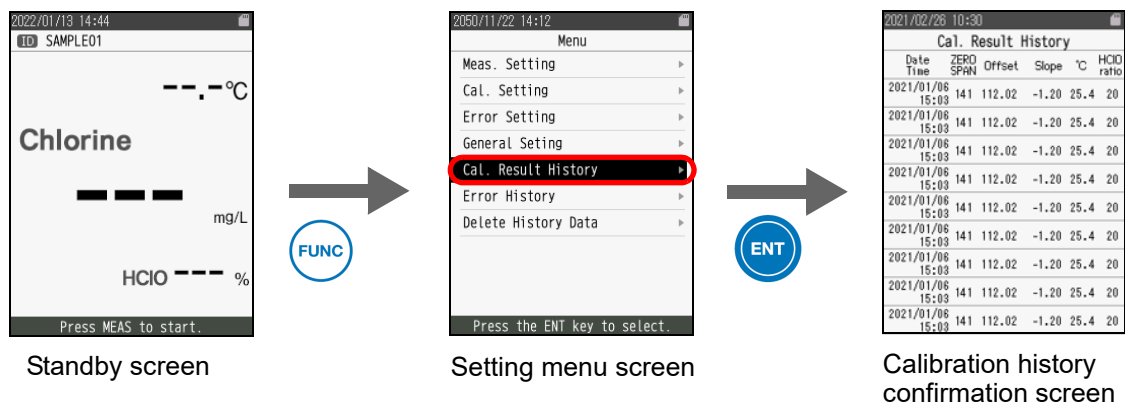
The latest nine calibration history confirmation screen is displayed.



Tip Press ◀ key on the measurement screen to display the calibration history screen. You can check the data of the latest nine calibrations. The older data than these nine items will be erased.
("Displaying the calibration screen from the measurement screen" (page 17))

 You can also confirm the screen operations in this chapter with a simple video.
 For the URL, refer to the "Display the history screen" section in "Watch the operation in the video" (page 83).

6.7 Error History

Errors can be confirmed.

1. Press the FUNC key on the standby screen.



Setting menu (MENU) screen is displayed.

2. Press the ▲▼ keys to select “Error History” and press the ENT key.

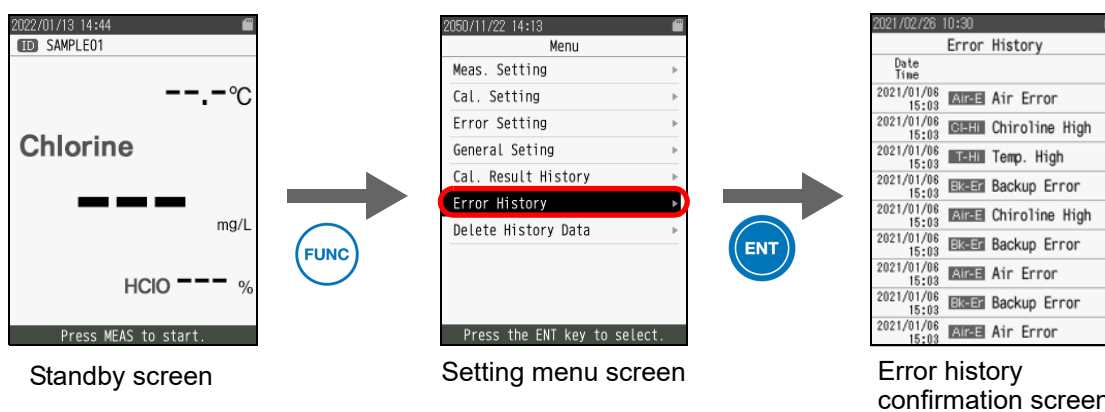
The error history confirmation is displayed.



Tip	Press ► key on the measurement screen to display the error history screen. You can check the data of the last nine errors. The older data than these nine items will be erased. ("Displaying the calibration screen from the measurement screen" (page 17))
------------	--

		<p>You can also confirm the screen operations in this chapter with a simple video.</p> <p>For the URL, refer to the "Display the history screen" section in "Watch the operation in the video" (page 83).</p>
---	---	---

6 Settings (Menu)

6.8 Delete History Data

6.8 Delete History Data

Delete the error history and calibration result history.

6.8.1 Delete the error history (Error History)

Delete the error history.

1. Press the FUNC key on the standby screen.
Setting menu (MENU) screen is displayed.
2. Press the ▲▼ keys to select “Delete History Data” and press the ENT key.
The history deletion screen is displayed.
3. Press the ▲▼ keys to select “Error History” and press the ENT key.
The confirmation screen to delete the error history is displayed.
4. Use the ◀▶ keys to select OK and press the ENT key to delete the error history.

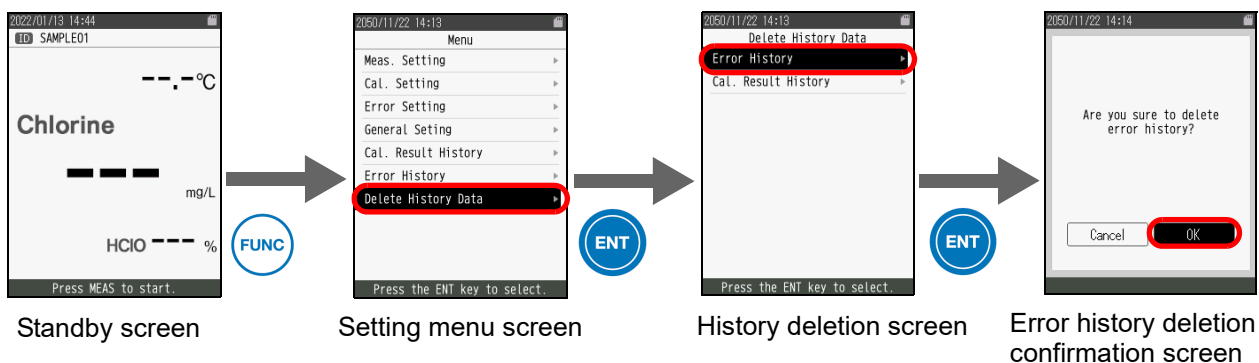

Tip	Press the ESC key to cancel the selected item.
-----	--

6.8.2 Delete the calibration result (Cal. Result History)

Delete the calibration result.

1. Press the FUNC key on the standby screen.
Setting menu (MENU) screen is displayed.
2. Press the ▲▼ keys to select “Delete History Data” and press the ENT key.
The history deletion screen is displayed.
3. Press the ▲▼ keys to select “Cal. Result History” and press the ENT key.
The confirmation screen to delete the calibration history is displayed.
4. Use the ◀▶ keys to select OK and press the ENT key to delete the calibration history.

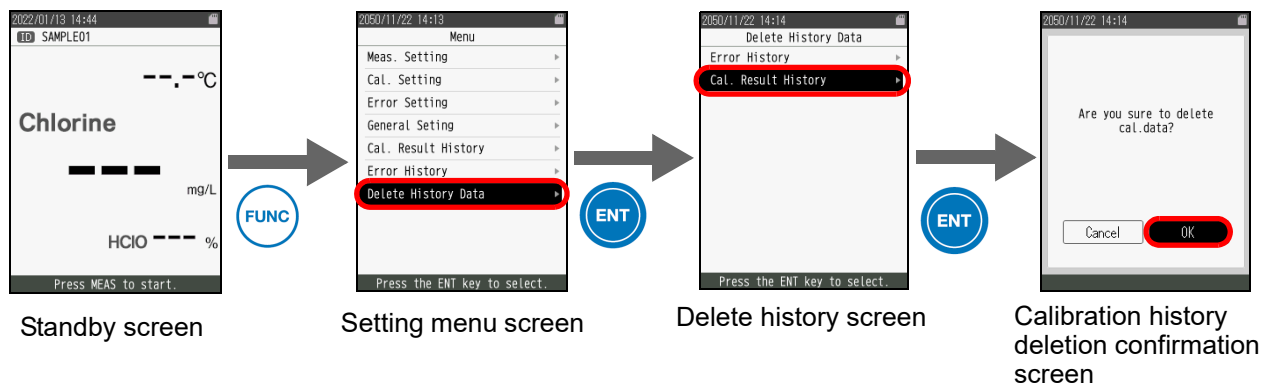

Tip	Press the ESC key to cancel the selected item.
-----	--

7 Save data to SD memory card

When SD memory card is inserted in the main unit, all measurement results are automatically saved in SD memory card.

Note	<ul style="list-style-type: none">● Please confirm the free space of the SD memory card.● If you are using micro SD memory card or miniSD memory card, please use the conversion adapter.● Do not remove/insert the SD memory card or turn off the power during measurement. Data can be damaged.● Keep the SD memory card from coming contact with water droplets.
-------------	--

7.1 Detachment of SD memory card

7.1.1 Attachment of the SD card

1. Remove the waterproof cap from the SD card insertion slot and insert the SD card until it becomes locked inside.

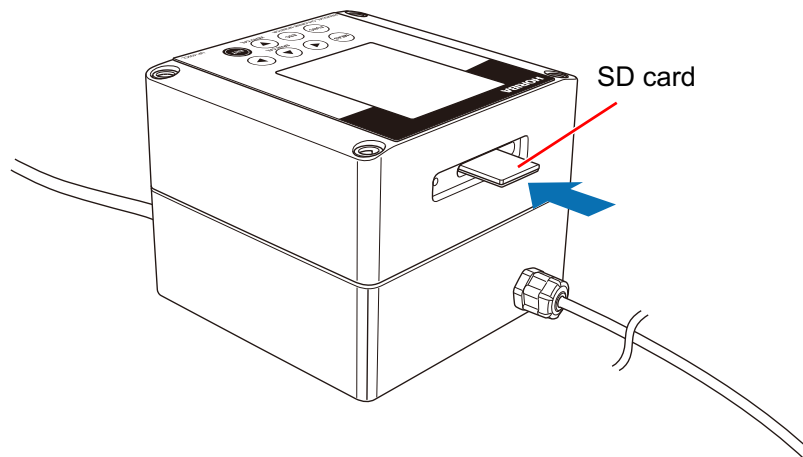

2. Close the waterproof cap.

Note	Be sure to attach the cap securely.
------	-------------------------------------

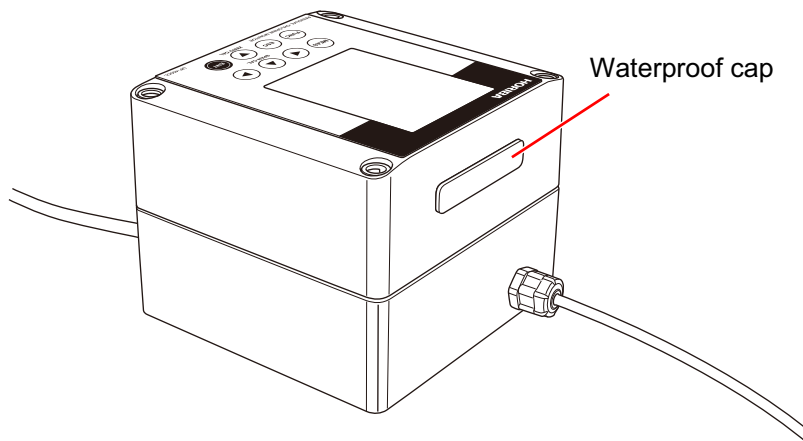

3. Confirm that the SD memory card icon is displayed on the screen.

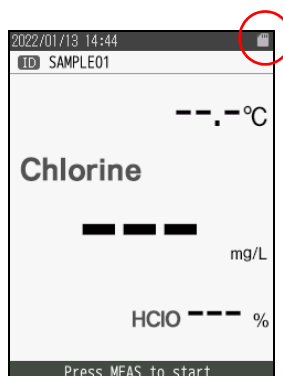

7 Save data to SD memory card

7.1 Detachment of SD memory card

7.1.2 Ejection of the SD card

1. Push the SD memory card.

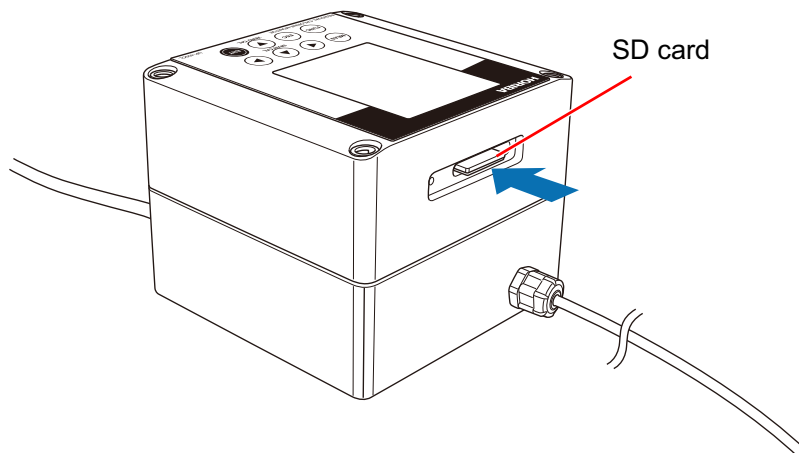

2. Lock is released and SD memory card comes out.

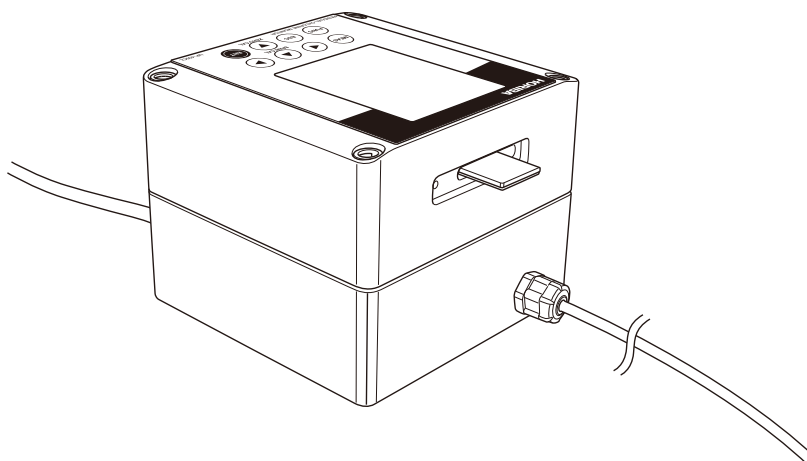

7.2 Save data

Data files are saved in the root directory of the SD memory card.

- One block data from start to stop is saved in a CSV file. A new file will be created automatically when the next measurement starts.
If the number of measurement results exceeds 100,000, new data will be created automatically.

- Naming rule of the files

The file name is configured with the ID of the user's device and the measurement start time defined by year, date, hour, minute, and second.

(Example) Device ID is HAT and measurement starts at 23:45:00 on January 25, 2021:

HAT_20210125234500.csv

When the Device ID is not set: _YYYYMMDDHHMMSS.csv

Note	<ul style="list-style-type: none"> • If a writing error or file creating error occurs due to occupied memory, etc., data will not be saved until next measurement start, even in the measurement mode. When an error occurs, the SD-Er indicator lights up. This indication will be automatically turned off when the instrument stops measurement and returns to be in standby mode. • If calibration is performed during measurement, the calibration data is saved at the same time. However, calibration data will not be saved if any calibration error occurs.
-------------	--

7.2.1 SD data file format

```

ABCDEFGHIJ_20210125234500.csv      ←Saved file name DeviceID_Year, Month, Day, Hour, Minute, Second.csv
//SETTING//
Device ID   ABCDEFGH   ←Device ID
MesN       3             ←Number of measurements after interval
Interval    0             ←Interval time (minutes)
AveN       1             ←Number of moving average times
//CALIBRATION//
Slope      255.73     ←Calibration factor (slope)
Offset     -9.74       ←Calibration factor (Intercept)
TempC      24.2     ←Calibration liquid temperature
Zero       0.0381  ←Combined current value at zero calibration
Span       0.2649  ←Combined current value at span calibration
HClO_ratio 80       ←Proportion of HClO presence (calculated from the value at the time of span calibration)
Span_Abs   80       ←Residual chlorine concentration input at calibration
//MEASUREMENT//
Y/M/D      Time      Cl      Temp      HClO Ratio  mA      Err1  Err2  Err3  Err4  Err5
2020/12/7  10:34:14  56      24.6      80          0.2602
2020/12/7  10:34:24  56      24.7      80          0.2611
2020/12/7  10:34:34  57      24.8      80          0.2635
2020/12/7  10:34:44  56      24.8      80          0.2619
2020/12/7  10:34:54  57      24.6      80          0.2627
2020/12/7  10:35:04  57      24.7      80          0.2630  Air-E
2020/12/7  10:35:14  280     24.8      80          0.2601  Air-E  Cl-Hi
2020/12/7  10:35:24  311     24.9      80          0.2625  Cl-Hi
2020/12/7  10:35:34  56      24.9      80          0.2626

```

↑
↑
↑
↑
↑
↑
↑

Year and Date Time Residual chlorine concentration value Liquid temperature Proportion of HClO presence Measured current value Error name
mg/L °C % mA

8 Errors and countermeasures

8.1 Error list and countermeasures

8 Errors and countermeasures

8.1 Error list and countermeasures

Error display	Error name	Initial value	User change availability	Temperature/ concentration screen display	Motion	Countermeasures
Cl-Hi	High concentration	100 mg/L	✓	Concentration value blinks	Measurement continues	It is above the upper limit of concentration. Confirm the condition of the liquid.
Cl-Lo	Low concentration	10 mg/L	✓	Concentration value blinks	Measurement continues	It is below the lower limit of concentration. Confirm the condition of the liquid.
Cl-Er	Outside the concentration range	1000 mg/L	–	Concentration value blinks	Measurement continues	Concentration is 1000 mg/L or more. Please confirm if the concentration is appropriate. Please confirm whether the liquid is flowing (Air-E).
T-Hi	High temperature	40°C	✓	Temperature value blinks	Measurement continues	It is above the temperature upper limit. Check the condition of the liquid.
T-Lo	Low temperature	5°C	✓	Temperature value blinks	Measurement continues	It is below the temperature lower limit. Confirm the condition of the liquid.
T-Er	Out of temperature range	50°C	–	Temperature value blinks	Measurement continues	Temperature exceeds 50°C. Lower the ambient temperature or liquid temperature.
		0°C	–	Temperature value blinks	Measurement continues	Temperature is below 0°C. Increase the ambient temperature or liquid temperature.
P-Mnt	Pump maintenance	5000 h	–	As usual	Measurement continues	The lifetime of the pump is coming soon. Pump replacement is recommended.
P-Er	Pump error	–	–	Standby	Measurement stops	There is a problem with the pump motor. Check that the pump connectors are securely connected. Replace a pump.

8 Errors and countermeasures

8.1 Error list and countermeasures

Error display	Error name	Initial value	User change availability	Temperature/ concentration screen display	Motion	Countermeasures
Air-E	No sample	–	–	Concentration value blinks	Measurement continues	Inside of the sensor is not filled with the sample liquid. Flush the liquid. The alarm is also triggered by liquids with very low conductivity, such as ion-exchanged water.
T-Uni	Internal temperature error	60°C	–	Standby	Measurement stops	The temperature inside the main unit has exceeded 60°C. Lower the ambient temperature or liquid temperature.
Sys-E Sys-A Sys-P Bk-Er	System error	–	–	Standby	Measurement stops	System error occurs inside the circuit. If the problem persists even after turning on the power again, please contact us.
SD-Er	SD memory error	–	–	As usual	Measurement continues	SD card write error occurs. Please check if there is free space on the SD card. Replace with a new SD card.

8 Errors and countermeasures

8.2 Problems without error display

8.2 Problems without error display

Problem description	Cause/Remedy
Screen is not displayed	<ul style="list-style-type: none">● Check the power supply.● Check that there is no liquid leakage inside the main unit.
Liquid does not flow	<ul style="list-style-type: none">● Check that the tube is not broken.● Replace the filter. <p>If the above methods do not work, the inside of the device may be clogged with dust. Try rinsing if there is even a little bit of liquid running.</p>
Indicated value drifts	<ul style="list-style-type: none">● Check that there is no sudden changes in temperature.● Check that the pH has not fluctuated.● Check that the samples concentration is constant.● Check that the measuring mode is correct.● Is measurement performed for the first time in a few days? Check that measurement becomes stable after measuring for a few hours.
Indicated value is unstable	<ul style="list-style-type: none">● Check that there is no sudden changes in temperature.● Check that the sample containing many air bubbles is not used.● Check that fittings, etc. are connected without leaks.● Check that the liquid is flowing.● Check that the measuring mode is correct.● Check that there is no noise source such as a pump nearby.
Indicated value does not match	Perform calibration.
Communication fails	<ul style="list-style-type: none">● Check the communication settings.● Check the power.

9 Communication and Input/Output specifications

9.1 Overview

The host system can control the UP-400CL through communication commands.

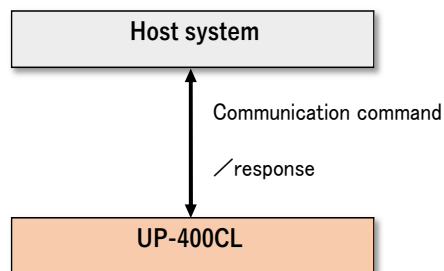

9.2 Communication parameters

No.	Item	Specifications	Remarks
1	Communication method	RS-232C	Half duplex
2	Baud rate	19200 bps	
3	Data bit	8 bits	
4	Stop bit	1 bit	
5	Parity	Even	
6	Flow control	None	
7	Transmission character code	ASCII code (range: 0x20-0x7f)	
8	STX	None	
9	ETX	"CR + LF" (0x0d0a)	
10	Transfer protocol	Non procedural protocol (command/response method)	

9 Communication and Input/Output specifications

9.3 Communication protocol

9.3 Communication protocol

Command response method

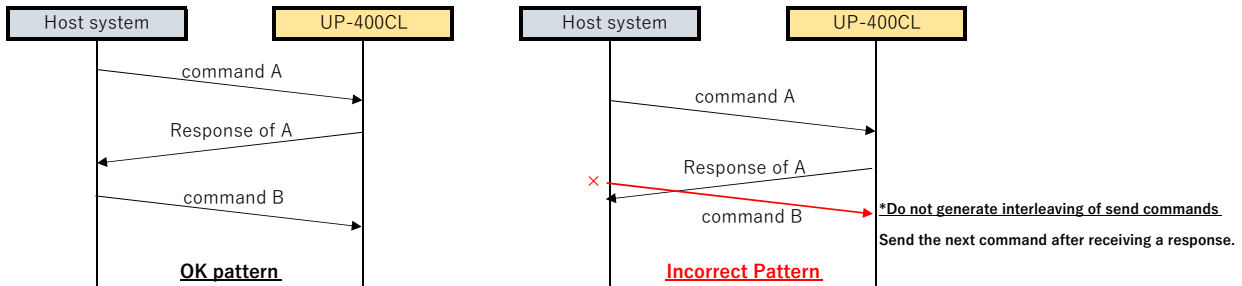

*The time interval between commands sent from the host should be 500 ms or more.

9.4 Command format

The commands are all sent in ASCII code, divided into headers, subheader, and parameters, with a comma ", " 0x2c separating the commands, and the closing code CR+LF (0x0d0a) appended at the end.

(Example) C,BK,1<CR><LF>

*The number of parameters varies depending on the command.

Header type	Meaning	Normal response	Error response
C	Control	OK<CR><LF>	Err,x<CR><LF>
S	Settings	OK<CR><LF>	Err,x<CR><LF>
R	Reading of data or settings	Subheader + Parameter<CR><LF>	Err,x<CR><LF>

Header type	Error number	Meaning	Details
Err,x	x=1	Header error	Header and subheader are undefined
	x=2	Format error	Parameter error, length error
	x=3	Out of parameter range	Parameter number value is out of range, numerical relationship is inappropriate
	x=4	Not accepted	This is unacceptable in the current system state
	x=5	Calibration error	Error response during span calibration in communication
	x=6	Other errors	EEPROM write failure, etc.

- When there is no data in response

(Transmission example) C,ME<CR><LF> → (Response example) OK<CR><LF>

- When data exists in response

(Transmission example) R,MC<CR><LF> → (Response example) MC,1,10,50,1<CR><LF>

*The sender subheader is returned as a response header.

9.5 Command reception table

Command name	Equipment status				
	Starting device	Standby	During measurements	During measurements (calibration screen)	Settings screen
Measurement start (C, ME)	x	✓	x	x	x
Measurement end (C, SP)	x	x	✓	✓	x
Zero calibration implementation (C, ZC)	x	x	△	x	x
Span calibration implementation (C, SC, xxx)	x	x	△	x	x
Read (R system commands)	x	✓	✓	✓	✓
Write settingsvalue (S system command)	x	✓	x	x	x
Backlight adjustment (C, BK, x)	x	✓	✓	✓	✓

✓: Acceptable

△: Response with Err,4 before measurement is not determined.
Response with Err,5 when an error occurs in calibration calculation after measurement is determined.

x: Response with Err,4 as unacceptable command input.

9 Communication and Input/Output specifications

9.6 Measurement sequence (example)

9.6 Measurement sequence (example)

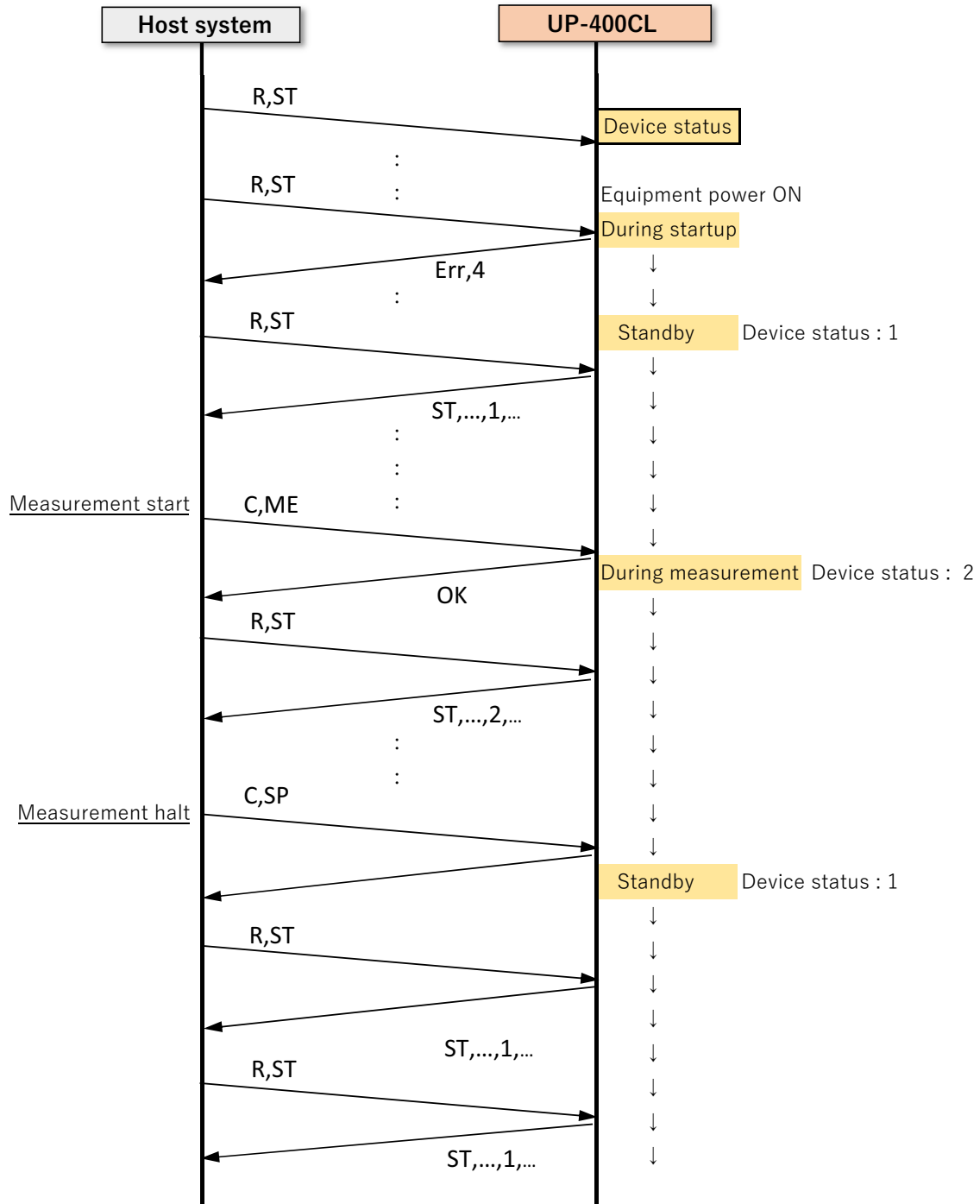

9.7 Communication commands to host computer

● Control command

Communication commands to host computer					
Command name	Send/receive format	Parameters	Parameter meaning	Range of parameters	Remarks
Control commands					
Measurement start	C,ME<CR><LF>				
Response	OK<CR><LF> or Err,x<CR><LF>				
Measurement stop	C,SP<CR><LF>				
Response	OK<CR><LF> or Err,x<CR><LF>				
LCD backlight ON/OFF	C,BK,①<CR><LF>				
	①	x	ON/OFF	0= OFF 1=ON	
Response	OK<CR><LF> or Err,x<CR><LF>				
Zero calibration implementation	C,ZC<CR><LF>				
Response (calibration success)	ZC,①,②<CR><LF>				
	①	-xxx.xx to xxx.xx	Slope (A)		Calibration run results (calibration coefficients)
	②	-xx.x to xx.x	Offset (B)		Calibration run results (calibration coefficients)
Response (calibration failure)	Err,5<CR><LF>				
	In case of calibration error				
Span calibration implementation	C,SC,①<CR><LF>				
	①	xxx	Concentration value	0 to 999	
Response (calibration success)	SC,①,②<CR><LF>				
	①	-xxx.xx to xxx.xx	Slope (A)		Calibration results
	②	-xx.x to xx.x	Offset (B)		Calibration results
Response (calibration failure)	Err,5<CR><LF>				
	In case of calibration error				

9 Communication and Input/Output specifications

9.7 Communication commands to host computer

● Setup command

Communication commands to host computer					
Command name	Send/receive format	Parameters	Parameter meaning	Range of parameters	Remarks
Setup command					
Measurement setup	S,MC,①,②,③,④<CR><LF>				
		①	x	Measurement mode	1 to 4 1: Oxidation, 2: Reduction, 3: Vegetable washing, 4: Oxidative reduction
		②	xxxxx	Measurement interval	0 to 30000 Unit min
		③	xxxxx	Measurement times after measurement interval	1 to 30000
		④	xx	Moving average count	1 to 240
Response	OK<CR><LF> or Err,x<CR><LF>				
Alarm level settings	S,AL,①,②,③,④<CR><LF>				
		①	xxx	Concentration upper limit	0 to 999 Concentration upper limit > Concentration lower limit
		②	xxx	Concentration lower limit	0 to 999 Concentration upper limit > Concentration lower limit
		③	xx.x	Temperature upper limit	0.0 to 99.9 Temperature upper limit > Temperature lower limit
		④	xx.x	Temperature lower limit	0.0 to 99.9 Temperature upper limit > Temperature lower limit
Response	OK<CR><LF> or Err,x<CR><LF>				
LCD dimmer setting	S,BR,①<CR><LF>				
		①	xx	Intensity	1 to 10 10 steps
Response	OK<CR><LF> or Err,x<CR><LF>				
Time setting	S,TM,①,②,③,④,⑤<CR><LF>				
		①	xxxx	Year	2021 to 2050
		②	xx	Month	1 to 12
		③	xx	Day	1 to 31
		④	xx	Hour	0 to 23
		⑤	xx	Minute	0 to 59
Response	OK<CR><LF> or Err,x<CR><LF>				
Device ID setting	S,DE,①<CR><LF>				
		①	xxxxxxxx	Device ID	0 to 8 ASCII characters If a character not specified for the ID code is input, the character is automatically converted to a space.
Response	OK<CR><LF> or Err,x<CR><LF>				
Factory reset	S,RT<CR><LF>				
Response	OK<CR><LF> or Err,x<CR><LF>				
Reset pump running time	S,PR<CR><LF>				
Response	OK<CR><LF> or Err,x<CR><LF>				

9 Communication and Input/Output specifications

9.7 Communication commands to host computer

Communication commands to host computer					
Command name	Send/receive format	Parameters	Parameter meaning	Range of parameters	Remarks
Setup command					
Manual calibration value setting	S,MA,①,②,③<CR><LF>				
	①	xx.x	Temperature (Tcal)	0.0 to 99.9	
	②	-xxx.xx to xxx.xx	Slope (A)	0.00 to 999.99	
	③	-xx.x to xx.xx	offset (B)	-99.9 to 99.9	
Response	OK<CR><LF> or Err,x<CR><LF>				
Error history clear	S,EC<CR><LF>				
Response	OK<CR><LF> or Err,x<CR><LF>				
Calibration value clear	S,CC<CR><LF>				Equivalent to the command of clearing the calibration value for manual calibration
Response	OK<CR><LF> or Err,x<CR><LF>				
Ratio display setting	S,CD,①<CR><LF>				Chlorine formation to present the ratio on the LED screen
	①	x	Existence ratio display	0 to 1	0 : HCLO 1 : CLO-
Response	OK<CR><LF> or Err,x<CR><LF>				
Readout of measurement settings	R,MC<CR><LF>				
Response	MC,①,②,③,④<CR><LF>				
	①	x	Measurement mode		
	②	xxxxx	Measurement interval		
	③	xxxxx	Measurement times after measurement interval		
	④	xx	Moving average count		
Alarm level readout	R,AL<CR><LF>				
Response	AL,①,②,③,④<CR><LF>				
	①	xxx	Concentration upper limit		
	②	xxx	Concentration lower limit		
	③	xx.x	Temperature upper limit		
	④	xx.x	Temperature lower limit		
LCD dimming readout	R,BR<CR><LF>				
Response	BR,①<CR><LF>				
	①	xx	Intensity		
Time readout	R,TM<CR><LF>				
Response	TM,①,②,③,④,⑤<CR><LF>				
	①	xxxx	Year		
	②	xx	Month		
	③	xx	Day		
	④	xx	Hour		
	⑤	xx	Minute		

9 Communication and Input/Output specifications

9.7 Communication commands to host computer

Communication commands to host computer					
Command name	Send/receive format	Parameters	Parameter meaning	Range of parameters	Remarks
Setup command					
Device ID readout	R,DE<CR><LF>				
Response	BE,①<CR><LF>				
	①	xxxxxxx	Device ID		
Manual calibration value readout	R,MA<CR><LF>				
Response	MA,①,②,③<CR><LF>				
	①	xx.x	Temperature (Tcal)		
	②	-xxx.xx to xxx.xx	Slope (A)		
	③	-xx.x to xx.xx	offset(B)		
Ratio display readout	R,CD<CR><LF>				
Response	CD,①<CR><LF>				
		x	Existence ratio display		0 : HCLO 1 : CLO-

9 Communication and Input/Output specifications

9.7 Communication commands to host computer

● Status acquisition command

Communication commands to host computer					
Command name	Send/receive format	Parameters	Parameter meaning	Range of parameters	Remarks
Status acquisition command					
Measured value acquisition	R,ST<CR><LF>				
Response	ST,①,②,③,④,⑤,⑥,⑦,⑧,⑨,⑩,⑪,⑫,⑬<CR><LF>				
	①	xxxx/xx/xx	Year, month, day		Date and time when the data was acquired
	②	xx:xx:xx	Hour, minute, second		Time when data was acquired
	③	xxx	Residual chlorine concentration	0 to 999 or ---	If the concentration value is not yet determined, "----" is displayed
	④	xx.x	Liquid temperature	0.0 to 99.9 or ---	Liquid temperature at time of measurement If the liquid temperature is not yet determined, "----" is displayed
	⑤	xxx	HClO	0 to 100 or ---	When the ratio display on the LCD screen is "----", "----" is displayed.
	⑥	xxx	CLO-	0 to 100 or ---	When the ratio display on the LCD screen is "----", "----" is displayed.
	⑦	x	Alarm state	0 to 8	0: No errors 1: Concentration upper limit 2: Concentration lower limit 3: Temperature upper limit 4: Temperature lower limit 5: Concentration upper limit and temperature upper limit 6: Concentration upper limit and temperature lower limit 7: Concentration lower limit and temperature upper limit 8: Concentration lower limit and temperature lower limit
	⑧	x	Device status	0 to 5	0: During startup 1: Standby 2: During measurement 3: During measurement Wait 4: Set mode 5: Unrecoverable error condition
	⑨	xxxxx	Error indicator	Character string	Error indicators (up to five items) for errors that currently occur. If no error occurs, "-" is displayed.
	⑩	xxxxx	Error indicator	Character string	Error indicators (up to five items) for errors that currently occur. If no error occurs, "-" is displayed.
	⑪	xxxxx	Error indicator	Character string	Error indicators (up to five items) for errors that currently occur. If no error occurs, "-" is displayed.
	⑫	xxxxx	Error indicator	Character string	Error indicators (up to five items) for errors that currently occur. If no error occurs, "-" is displayed.
	⑬	xxxxx	Error indicator	Character string	Error indicators (up to five items) for errors that currently occur. If no error occurs, "-" is displayed.

9 Communication and Input/Output specifications

9.7 Communication commands to host computer

Communication commands to host computer					
Command name	Send/receive format	Parameters	Parameter meaning	Range of parameters	Remarks
Status acquisition command					
Latest calibration results acquisition	R,CR<CR><LF>				
Response	CR,①,②,③,④,⑤,⑥,⑦,⑧,⑨,⑩,⑪<CR><LF>				Returns the latest calibration results.
	①	xxxx/xx/xx	Year, month, day		Date when calibration was performed
	②	xx:xx:xx	Hour, minute, second		Time when the calibration was performed
	③	x	Zero/Span	0, 1	0: Zero calibration, 1: Span calibration
	④	xx.x	Temperature (Tcal)		If calibration has not been performed, it shall be considered blank.
	⑤	xxx	Slope (A)		If calibration has not been performed, the default value is returned.
	⑥	xxx	offset (B)		If calibration has not been performed, the default value is returned.
	⑦	x.xxx			Current value at zero calibration on the reduction side If calibration has not been performed, blank will be set.
	⑧	x.xxx			Current value at reduction side span calibration If calibration has not been performed, blank will be set.
	⑨	x.xxx			Current value at oxidation side zero calibration If calibration has not been performed, blank will be set.
	⑩	x.xxx			Current value at oxidation side span calibration If calibration has not been performed, blank will be set.
	⑪	xxx	HClO	0 to 100	If calibration has not been performed, blank will be set.

Error history acquisition	R,EH<CR><LF>				
Response	EH,①②③④,⋯<><>				Up to 9 items in order from the latest
	①	x.xx	Soft version	1.00 to	
	②	xxxx/xx/xx	Year, month, day		1st item
	③	xx:xx:xx	Hour, minute, second		
	④	xxxxx	Error indicator	Character string	
	:	xxxx/xx/xx	Year, month, day		2nd item
	:	xx:xx:xx	Hour, minute, second		
	:	xxxxx	Error indicator		
	:		:		:
	:		:		:
	:	xxxxx	Error indicator	Character string	9th item
	:	xxxx/xx/xx	Year, month, day		
	:	xx:xx:xx	Hour, minute, second		
	:	xxxxx	Error indicator	Character string	

9.8 Communication cable connection

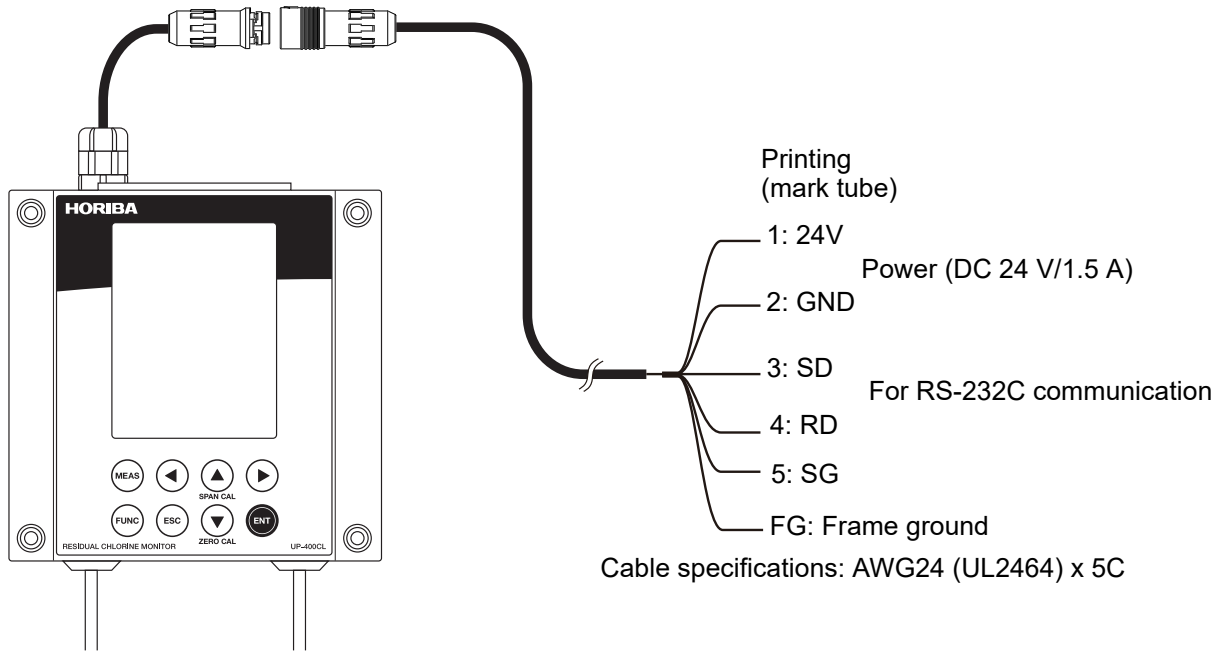

9.8.1 RS-232C connection

Example of communication cable connection

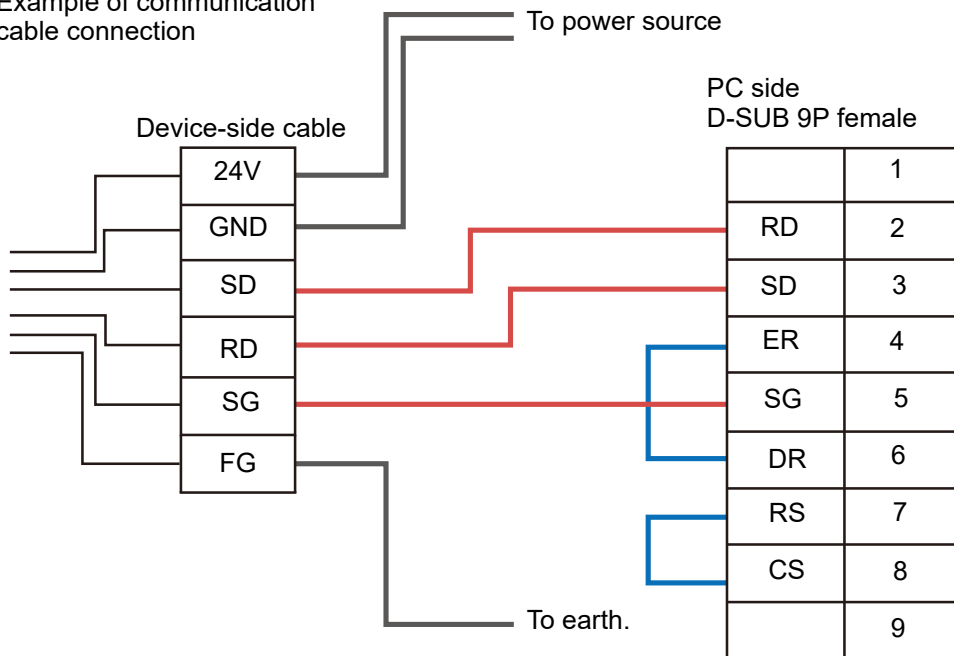

Note	<ul style="list-style-type: none"> ● RS, CS, ER, DR are not supported. Short-circuit between them if necessary. ● If there is a device that generates a large amount of noise around the installation location of the device, it may be affected by the noise through the wiring. When installing in such a place, take noise countermeasures such as FG connection to the earth, using a shield cable for wiring, and attaching a ferrite core. ● Turn off the power when connecting to RS-232C, analog output, or parallel input/output terminals.
------	---

9 Communication and Input/Output specifications

9.9 Communication unit connection

9.9 Communication unit connection

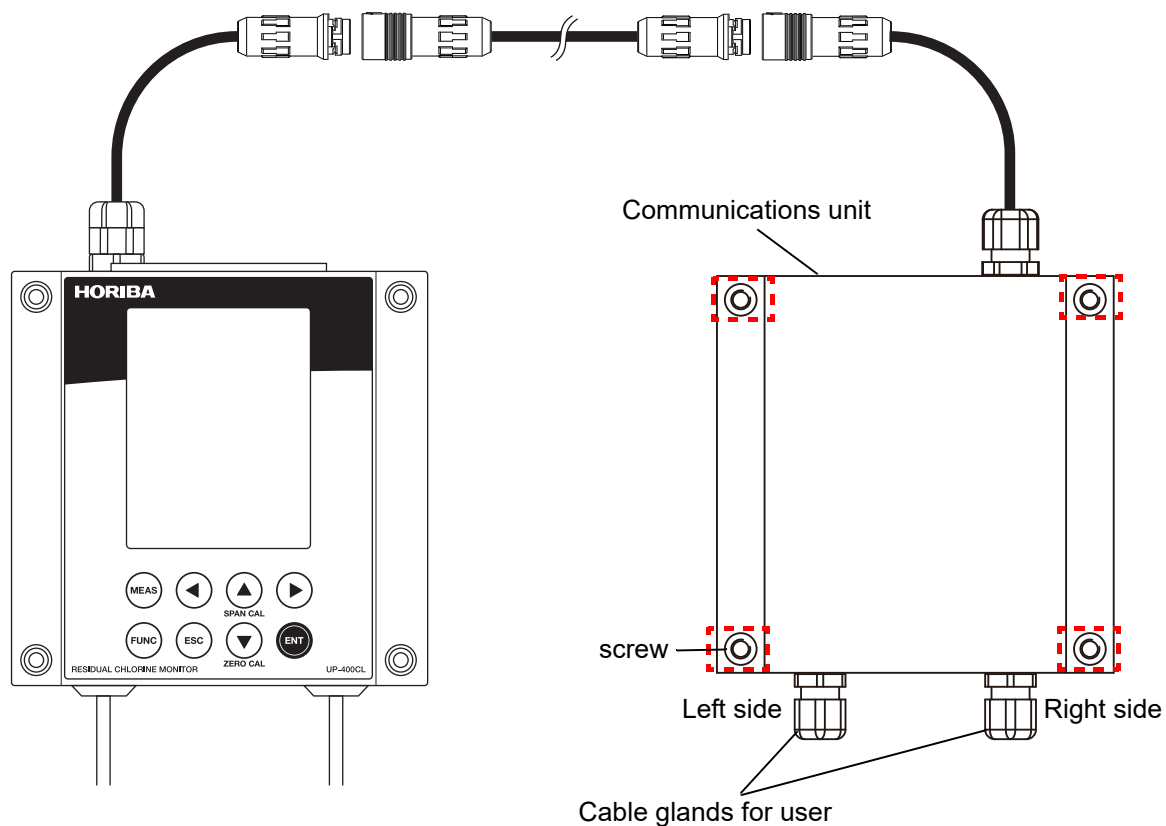

1. Loosen the screws at the four corners of the communication unit and open the lid.
2. After passing the cable through the cable glands (2 places), connect the wires to the terminals respectively.
3. Tighten the four corner screws and close the lid.

Tip	The compatible cable diameter of the cable gland differs between the left and right sides of the diagram above. <ul style="list-style-type: none">● Left side: 3.5 mm to 7 mm● Right side: 6.5 mm to 7.8 mm
-----	--

Attach a sealing plug (ex: SP-12 Takachi Denki Kogyo) to unused cable glands.

9.9.1 RS-232C connection

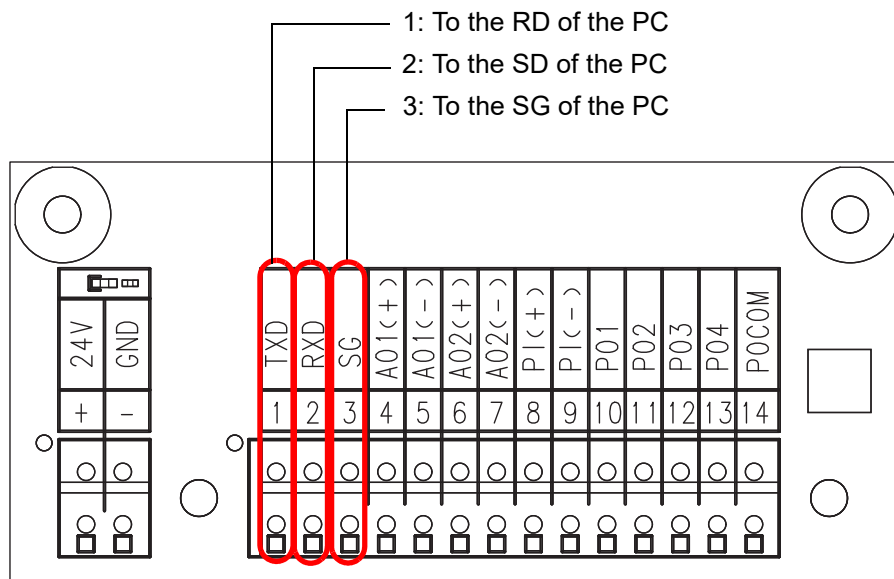

Note	<ul style="list-style-type: none"> ● RS, CS, ER, DR are not supported. Short-circuit between them if necessary. ● If there is a device that generates a large amount of noise around the installation location of the device, it may be affected by the noise through the wiring. When installing in such a place, take noise countermeasures such as FG connection to the earth, using a shield cable for wiring, and attaching a ferrite core. ● Turn off the power when connecting to RS-232C, analog output, or parallel input/output.
-------------	---

9 Communication and Input/Output specifications

9.10 Terminal block connection

9.10 Terminal block connection

Stranded wire connection cross section: 0.2 mm² to 1.5 mm²
 Suitable wire gauge: AWG24 to 16
 Suitable wire cross section: 0.25 mm² to 0.75 mm²
 Peeling length: 8 mm

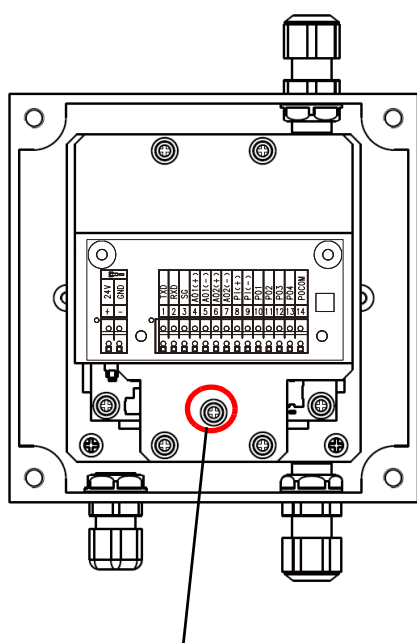

Connect FG to screw (M3) here.

+	24V	Power input 24 V
-	GND	Power input GND
1	TXD	For RS-232C communication with main unit TXD
2	RXD	For RS-232C communication with main unit RXD
3	SG	For RS-232C communication with main unit SG
4	AO1 (+)	Residual chlorine concentration analog output 1 (+)
5	AO1 (-)	Residual chlorine concentration analog output 1 (-)
6	AO2 (+)	Liquid temperature analog output 2 (+)
7	AO2 (-)	Liquid temperature analog output 2 (-)
8	PI (+)	Measurement start signal input (+)
9	PI (-)	Measurement start signal input (-)
10	PO1	Signal output 1 for high concentration error
11	PO2	Signal output 2 for low concentration error
12	PO3	Signal output 3 for other errors
13	PO4	Unused
14	PCOM	Circuit common for the signal output

Note	<ul style="list-style-type: none"> ● RS, CS, ER, DR are not supported. Short-circuit between them if necessary. ● If there is a device that generates a large amount of noise around the installation location of the device, it may be affected by the noise through the wiring. When installing in such a place, take noise countermeasures such as FG connection to the earth, using a shield cable for wiring, and attaching a ferrite core. ● Turn off the power when connecting to RS-232C, analog output, or parallel input/output.
-------------	---

9.10.1 Electrical current output connection

UP-400CL is equipped with a function to output free chlorine concentration and measured liquid temperature as an electrical current signal. Refer to "Communication unit connection" (page 64) for the connection method.

- Connection of current output 1 (concentration) and current output 2 (liquid temperature)

Electrical current output 1 outputs the electrical current corresponding to the concentration. Electrical current output 2 outputs the electrical current corresponding to the liquid temperature.

20 mA is output when concentration is 500 mg/L or more, and temperature is 100°C or more.

1.5 mA is output when measurement is not performed.

Terminal name	Output type	Output	Instruction value
Electrical current output 1	Concentration	4 mA	0 mg/L
		20 mA	500 mg/L
Electrical current output 2	Liquid temperature	4 mA	0.0°C
		20 mA	100.0°C

Connect the signal cables to the following terminals.

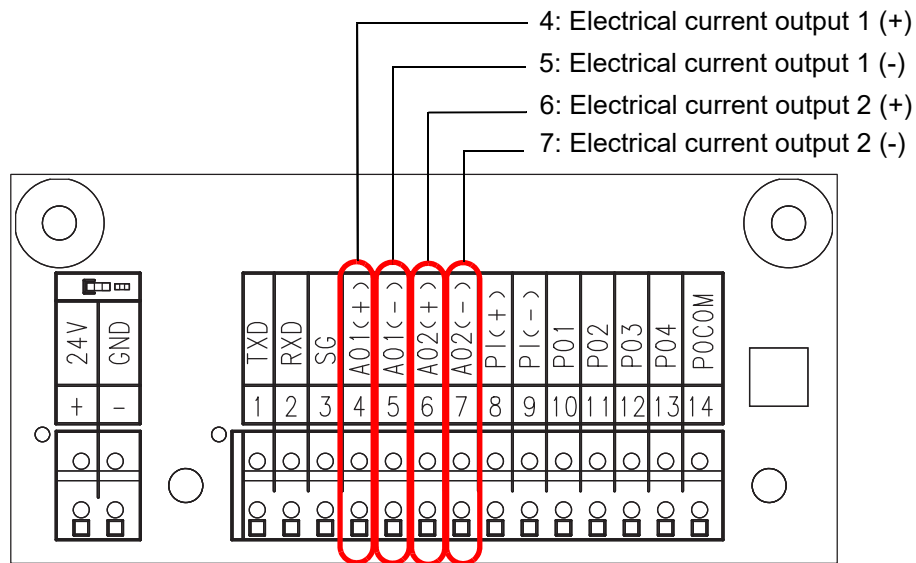

Note	The load resistance should be within 500 Ω for both current output 1 and 2.
-------------	---

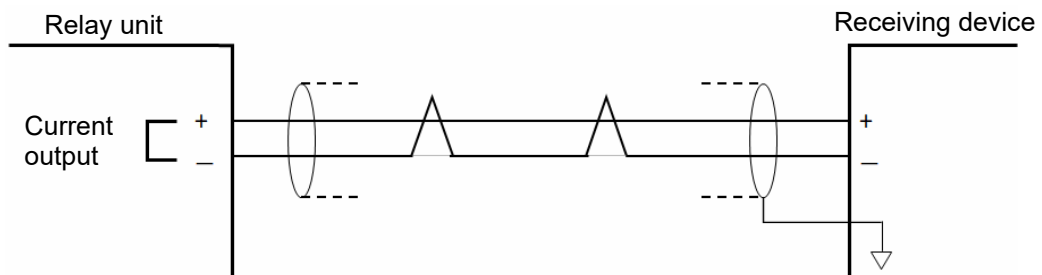

Note	Use shielded wires for current outputs 1 and 2 to avoid noise. Connect the shield wire to ground (or common) on the receiving device.
-------------	---

9 Communication and Input/Output specifications

9.10 Terminal block connection

9.10.2 Signal input/output connection

UP-400CL is equipped with signal input/output function.

- The input signal controls measurement start/stop.
- Signal output allows you to know the error output category.

● Signal Input

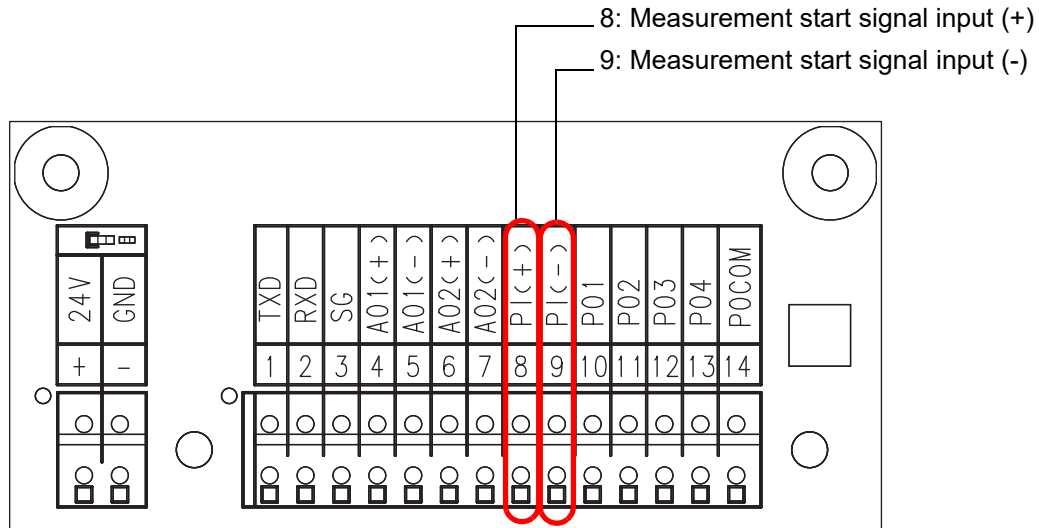

● Measurement start/stop control

Measurement start/stop is controlled by the input signal.

Action	Input signal
Start measurement	Apply voltage. Voltage range: DC 12V to 30 V
Stop measurement	Do not apply voltage. (No current flow to the photocoupler)

● Signal input specification

Refer to the input circuit inside the UP-400CL below.

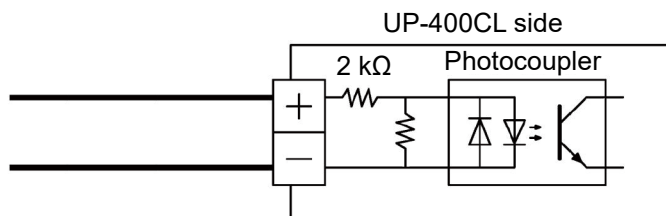

● Signal output

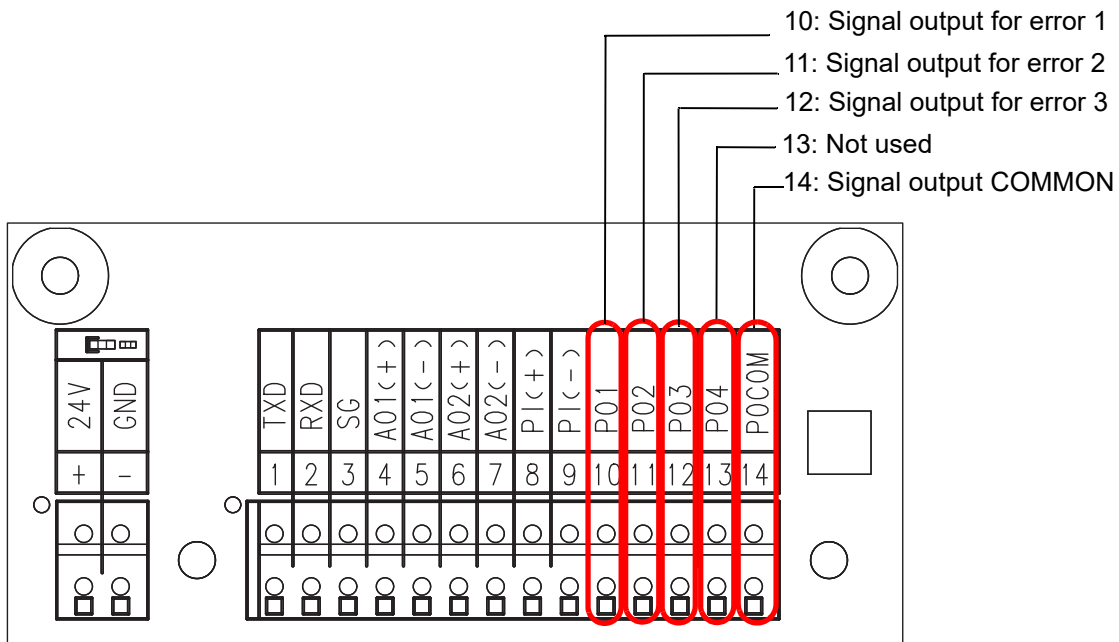

When signal is ON

Output transistor: ON

Maximum current when ON: DC 5 mA

When signal is OFF

Output transistor: OFF

Maximum voltage applied when OFF: DC 30 V

● Signal output specification

Signal output is an open collector output.

The output circuit inside the UP-400CL is shown.

(-) side is common (14: COMMON for signal output).

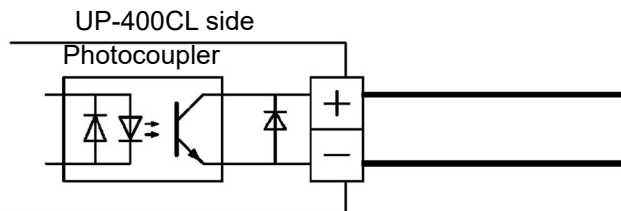

Note	The signal output does not have an electrical current limiting resistor. Direct connection to the power source without resistor or applying reverse voltage will damage the circuit.
-------------	--

10 Maintenance

10.1 Contact for maintenance

10 Maintenance

10.1 Contact for maintenance

For any technical inquiries or consultations for the maintenance, contact HORIBA Advanced Techno.

10.2 List of replacement parts

● Replacement parts

Part name	Model/Details	Item code
Pump unit	UP-40-PUM	3200959111
Sensor unit	UP-40-SEN	3200959119
Filter	ILF-3-100-UP	3200959137
Tube fitting (3 mml type bamboo shoot Tube fitting)	Tube fitting MCI-2-CN-UP	3200959126

● Optional parts

Part name	Model/Details	Item code
External mounting foot (4 pieces)	Mounting foot SFL-1-UP	3200959125
Rubber foot	Rubber foot SF11-3	3200959138
Pole mounting metal fittings	Pole mounting metal fittings	3200959698
Pole mounting metal fittings (Pole mounting screw)	Stainless steel screw set	3200959699
Pole mounting metal fittings (Pole mounting belts)	Pole fixing belts	3200959700
Inline strainer unit (for $\phi 3$ mm, mesh 80)	UP-40-ILS-3	3200998444
Tube (Silicon tube $\phi 3 \times \phi 6 \times 10$ M)	Silicon tube 3x6 10 M	3200959696
AC adapter	AKA-24016	3200940165
Stainless punching filter	Consult us	-

10.3 Maintenance item

Maintenance work for this product is as follows:

- "10.4 Daily maintenance" (page 71)
- "10.5 Periodical maintenance" (page 71)
- "10.6 Sensor and pump replacement" (page 72)
- "10.7 Care for moving" (page 74)
- "10.8 Long suspension" (page 74)

For maintenance work other than the above, ask our service personnel.

10.4 Daily maintenance

Check the following items daily after measurement.

- Are the samples and waste flowing correctly?
- Are there any errors?
- Are there any liquid leaks?
- Is there any discoloration on the exterior?
- Is the waterproof cap of the SD card slot secured?
- After measurement of the sample including vegetables or the sample which needs an optional in-line strainer, has the inside of the main unit been cleaned by measuring tap water?

10.5 Periodical maintenance

Please confirm the following items regularly.

- Chalky component derived from Calcium will adhere to the inside wall of the sampling line after long time use. Perform citric acid cleaning regularly, because the tube may be clogged with solid, which may cause leakage. Once every two months or so, measuring about 10% to 20% citric acid solution for 10 minutes will remove the chalky component inside. Always calibrate after citric acid cleaning.
- If the end of the sampling tube on the tube fitting becomes deformed or deteriorated, cut off the tip with scissors and re-joint with a new cut end.
- When the outlet side tube becomes deteriorated, purchase replacement parts and replace it with a new one.
- The attached filter is a consumable part. Please replace it regularly.
- For the specifications of replacement parts, please confirm the "List of replacement parts" (page 70).

10 Maintenance

10.6 Sensor and pump replacement

10.6 Sensor and pump replacement

10.6.1 Sensor replacement

Prepare a screw driver.

1. After measuring tap water, let the air inlet and make the inside sampling line vacant.
2. Turn off the power supply of the main unit, then move the unit to the secured place free from water splash.
3. Loosen the four corner screws and open the device cover.
The cable is connected, so open it carefully.
4. Disconnect the sensor connector.
Push the latch and pull the connectors to disconnect them.
5. Remove the two screws holding the sensor's fixing plate on the device.
6. Pinch the tube clips for the inlet and outlet of the sensor, and move them off the connecting point.
7. Remove the tubes connected to the inlet and outlet of the sensor.
Water may come out, so wipe up water with a cloth.
8. Remove the two screws, and remove the fixing plate and sensor.
Removal of the sensor is complete.
9. Attach the new sensor to the fixing plate with the two screws you removed.
10. Put the tubes on the tube fittings completely for the inlet and outlet of the sensor.
Firmly push the tubes covering the tube fittings entirely.
11. Pinch the tube clips and move them on the connecting point of the inlet and outlet of the sensor.
12. Attach the sensor and fixing plate to the device with the two screws you removed.
13. Put the sensor connector.
Put it all the way.
14. Attach the device cover and fasten the four corner screws.
Check that there is no dust on the packing of the case.
Make sure that cables have not got caught in the case.
15. Install the main unit again.



You can confirm the procedure with a video.

For the URL, refer to the "Sensor replacement" section in "Watch the operation in the video" (page 83).

10.6.2 Pump replacement

Prepare a screw driver.

1. After measuring tap water, let the air inlet and make the inside sampling line vacant.
2. Turn off the power supply of the main unit, then move the unit to the secured place free from water splash.
3. Loosen the four corner screws and open the device cover.
The cable is connected, so open it carefully.
4. Disconnect the pump and sensor connector.
Push the latch and pull the connectors to disconnect them.
5. Remove the two screws holding the sensor's fixing plate on the device.
6. Hold the tube clips for the tube between the pump and the sensor, and move them off the connecting point.
7. Remove the tube between the pump and the sensor.
Water may come out, so wipe up water with a cloth.
8. Remove the two screws holding the pump and the device together.
9. After the metal plate and sensor are loosened, pull out the tube through the bushing slowly.
The bushing may be detached if you pull the tube hard. If the bushing is detached, attach it to the device after removing the tube.
10. Take out the tube clips from the tube of the pump.
Keep them to reuse for a new pump installation.
11. Pressing the latch holding the pump on the plate, remove the pump from the plate.
Pump removal is complete.
12. Attach a new pump to the fixing plate.
Pay attention to the orientation of the pump.
Push it in until you hear a "click" sound.
13. Insert the longer tube into the bush from the inside of the device.
It's very stiff. Push it slowly, and when you can grasp the tip, slowly pull it out.
14. Attach a tube clip to the shorter tube.
15. Put the shorter tube on the sensor outlet completely.
Firmly push the tubes covering the tube fittings entirely.
16. Pinch the tube clips and move them on the connecting point of the outlet of the sensor.
17. Attach the pump and fixing plate to the device with the two screws you removed.
18. Attach the sensor and fixing plate to the device with the two screws you removed.

10 Maintenance

10.7 Care for moving

19. Put the pump and the sensor connector.

Put them all the way.

20. Attach the device cover and fasten the four corner screws.



Check that there is no dust on the packing of the case.
Make sure that cables have not got caught in the case.

21. Install the device again.

22. Operate pump reset. ("Pump Reset" (page 40))



If the cap comes off internal parts may fall off.
If it comes off, put it back on.

		<p>You can confirm the procedure with a video.</p> <p>For the URL, refer to the " Pump replacement" section in "Watch the operation in the video" (page 83).</p>
---	---	--

10.7 Care for moving

Turn off the power supply when you move the main unit.
Leakage may occur upon the sampling tube connection.

10.8 Long suspension

Store this product after performing the following procedure.

1. Measure tap or well water as sample for approximately 3 minutes.

The inside of the product is replaced with water.

2. Remove the sample suction tube (Inlet) from piping and measure for about 3 minutes.

The inside of the product is replaced with air.

3. Press the MEAS key.

Confirm that measurement has stopped and the standby screen is displayed.

4. Turn off the power.

When using the AC adapter, unplug the adapter's plug from the outlet.
When connecting to a PC or PLC, please contact a qualified electrician.

11 Disposal of the product

When disposing of the product, follow the related laws and/or regulations of your country.

11.1 Body disposal

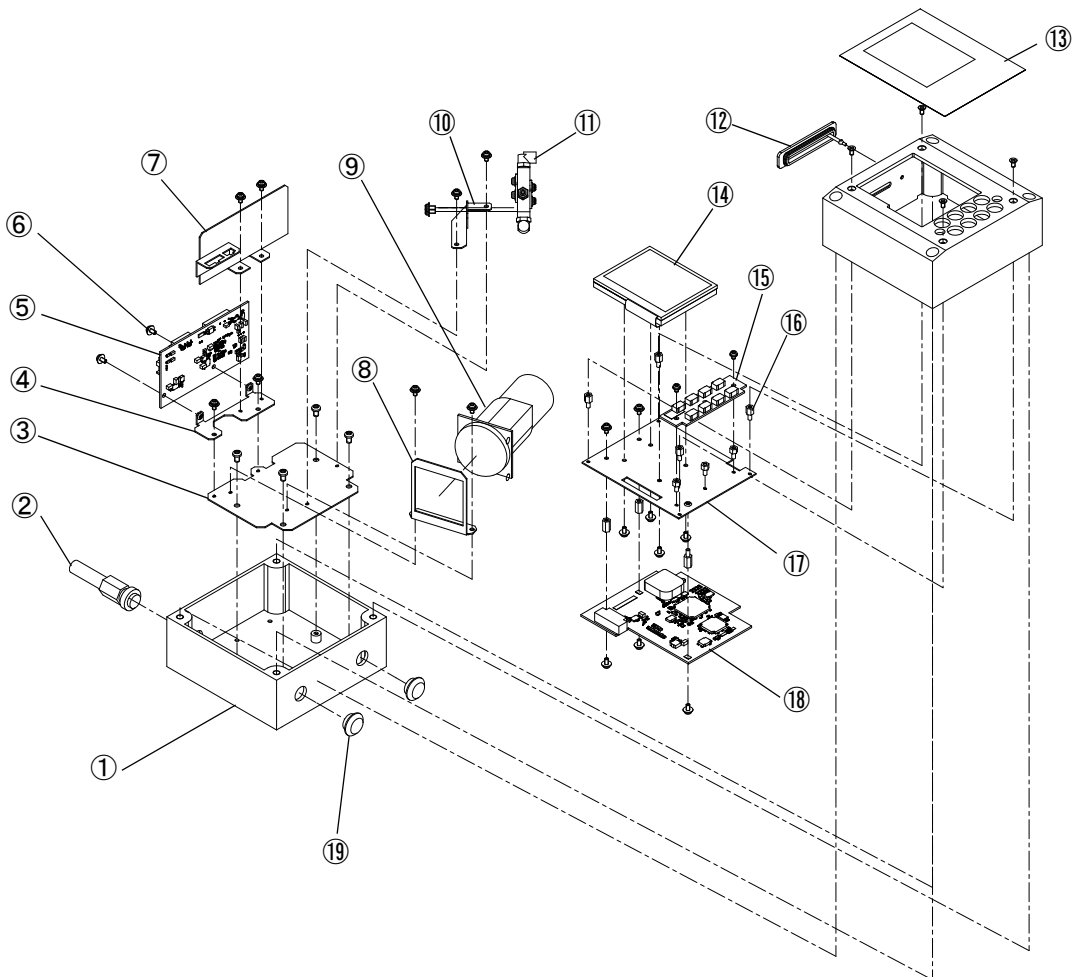

Number	Name	Material	Number	Name	Material
1	Case	PC	11	Cell	PVC, SUS, Ag, Pt, PP
2	Cable gland	PA66, NBR	12	SD card cover	Q
3	Base plate	SUS304	13	Key sheet	PET
4	PCB base	SUS304	14	LCD	Printed circuit board
5	Printed circuit board	Printed circuit board	15	Printed circuit board	Printed circuit board
6	Screw	SUS304	16	Stay	SUS304
7	PCB cover	SUS304	17	LCD base	SUS304
8	Fixed plate	SUS304	18	Printed circuit board	Printed circuit board
9	Tubing pump	Olefin resin, motor	19	ARM BUSHING	EPDM
10	Cell holder	SUS304			

11 Disposal of the product

11.2 Communication unit disposal

11.2 Communication unit disposal

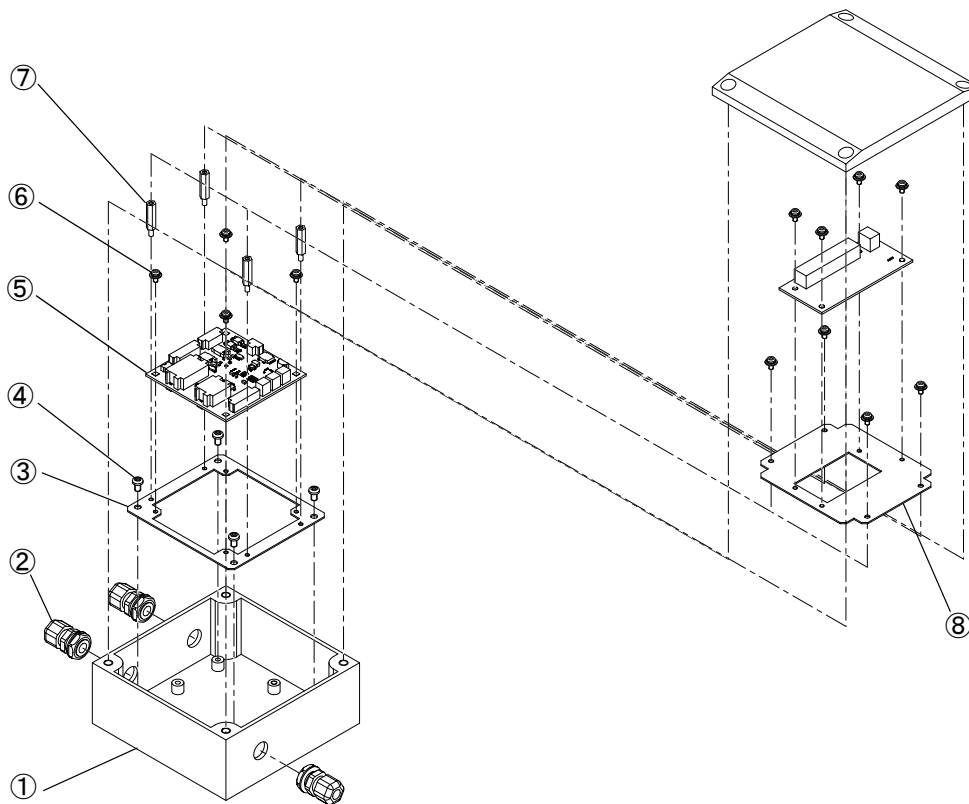

Number	Name	Material
1	Case	PC
2	Cable gland	PA66, NBR
3	Base plate	SUS304
4	Tap tight screw	Iron
5	Printed circuit board	Printed circuit board
6	Screw	SUS304
7	Stay	SUS304
8	Cover plate	SUS304

12 Reference

12.1 Regulations

12.1.1 EU regulations

- Conformable standards

This equipment conforms to the following standards:



EMC: EN 61326-1
Class A, Industrial electromagnetic environment
RoHS: EN IEC 63000
9. Monitoring and control instruments including industrial monitoring and control instruments

Warning: This is a Class A product. In a domestic environment this product may cause radio interference in which case the user may be required to take adequate measures.

<p>Note</p>	<ul style="list-style-type: none"> ● When the sensor cable, the transmission cable, or the contact input cable is extended to 30 m or longer, the surge test specified in the EMC directive for CE marking is not applied. ● The screen may flicker under the influence of radiated, radio-frequency, electromagnetic fields.
--------------------	---

- Information on disposal of electrical and electronic equipment and disposal of batteries and accumulators

The crossed out wheeled bin symbol with underbar shown on the product or accompanying documents indicates the product requires appropriate treatment, collection and recycle for waste electrical and electronic equipment (WEEE) under the Directive 2012/19/EU, and/or waste batteries and accumulators under the Directive 2006/66/EC in the European Union. The symbol might be put with one of the chemical symbols below. In this case, it satisfies the requirements of the Directive 2006/66/EC for the object chemical.

This product should not be disposed of as unsorted household waste.

Your correct disposal of WEEE, waste batteries and accumulators will contribute to reducing wasteful consumption of natural resources, and protecting human health and the environment from potential negative effects caused by hazardous substance in products.

Contact your supplier for information on applicable disposal methods.

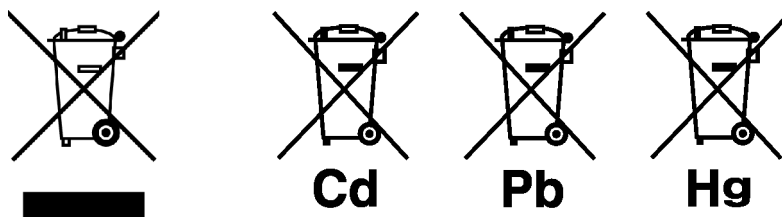

12 Reference

12.1 Regulations

12.1.2 FCC rules

- FCC compliance statement

This device complies with part 15 of the FCC Rules. Operation is subject to the following two conditions: (1) This device may not cause harmful interference, and (2) this device must accept any interference received, including interference that may cause undesired operation.

- Responsible party for FCC matter

HORIBA Instruments Incorporated
Head Office
9755 Research Drive
Irvine, California 92618 USA
+1 949 250 4811

- Note

This equipment has been tested and found to comply with the limits for a Class A digital device, pursuant to part 15 of the FCC Rules. These limits are designed to provide reasonable protection against harmful interference when the equipment is operated in a commercial environment. This equipment generates, uses, and can radiate radio frequency energy and, if not installed and used in accordance with the instruction manual, may cause harmful interference to radio communications. Operation of this equipment in a residential area is likely to cause harmful interference in which case the user will be required to correct the interference at his own expense.

Any changes or modifications not expressly approved by the party responsible for compliance could void the user's authority to operate the equipment.

12.1.3 Korea certification

A급 기기 (업무용 방송통신기자재)

이 기기는 업무용(A급) 전자파적합기기로서 판매자 또는 사용자는 이 점을 주의하시기 바라며, 가정외의 지역에서 사용하는 것을 목적으로 합니다.

12.1.4 Taiwan battery recycling mark



廢電池請回收

13 Document

13.1 Measuring principle

The measuring principle is a voltammetry method using a diamond electrode (BDD (Boron-Doped Diamond) electrode) as the working electrode.

Residual chlorine is generally classified into free residual chlorine and combined chlorine, as shown in the figure below, and free chlorine is further classified into chlorine (gas), hypochlorous acid (HClO), and hypochlorite ion (ClO⁻). This product can be used to measure free chlorine hypochlorous acid and hypochlorite ion.

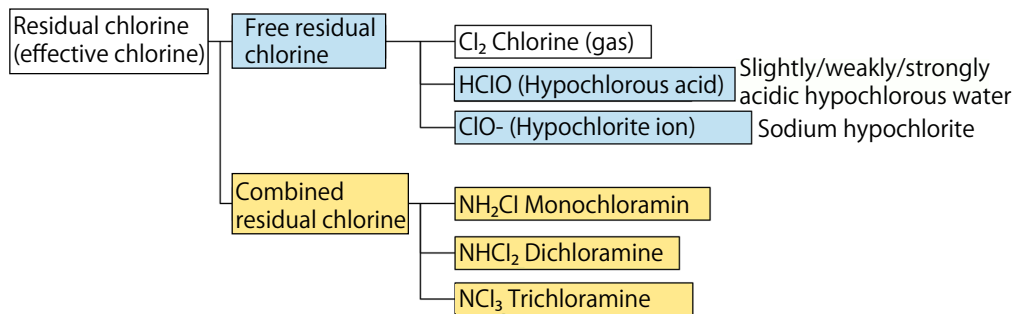

Form of residual chlorine

13 Document

13.1 Measuring principle

The ratio of hypochlorous acid and hypochlorite ion changes depending on the pH of the solution as shown in the figure below. Hypochlorous acid is said to have several tens of times high sterilization power than hypochlorite acid ion.

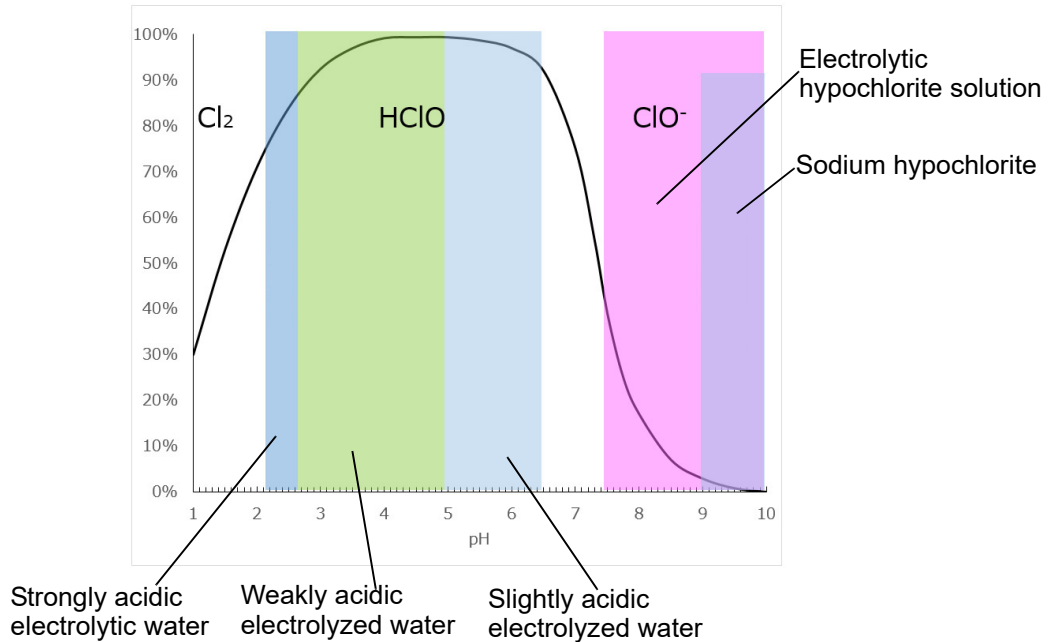

Abundance ratio of hypochlorous acid (HClO) and hypochlorite ion (ClO⁻) by pH change

For measuring hypochlorous acid, a negative voltage is applied to the working electrode and the reduction current generated is measured. For measuring hypochlorite ion, a positive voltage is applied to the working electrode and the oxidation current generated is measured. From these current values, the respective concentrations are calculated.

Hypochlorous acid concentration and hypochlorite ion concentration can be measured respectively, allowing calculation of existence ratios and pH-insensitive measurements.

By performing electrical preprocessing (electrolytic polishing) in advance of measurement, organic and inorganic substances adhering to the electrodes can be removed, and measurements can always be performed with clean electrodes. In the past, a method called bead polishing was used in which particles were applied to the electrode for polishing, but this product does not require bead polishing.

In addition, the measurement during vegetable rinsing uses a unique measurement sequence that reduces the effects of organic matter eluted from vegetables.

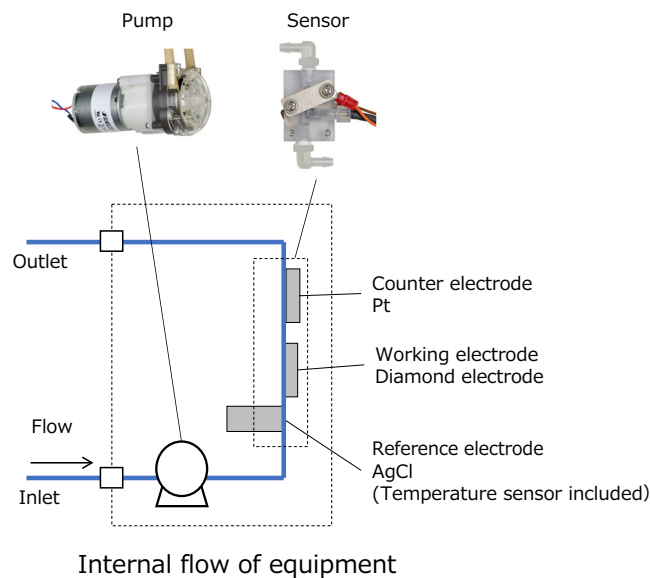

13.2 Specifications

Item		Details
General	Model name	UP-400CL
	Measuring principle	Voltammetry method
	Substance to be measured	Free residual chlorine
	Solution to be measured	Slightly acidic electrolyzed water, weakly acidic electrolyzed water, pH controlled hypochlorite water sodium hypochlorite water, electrolyzed hypochlorous water (Raw water quality must comply with the water supply law.)
	Equipment size	W125 x H100 x D125 mm (Excluding protruding parts) (Analog communication model comes with a separate communication unit (W125 x H60 x D125 mm))
	Power	DC 24 V \pm 10%, rated 12 W (Models without communication come with AC adapter (100 V to 240 V AC, 50 Hz to 60 Hz))
Performance	Measurable range	Acidic neutral solutions such as slightly acidic electrolyzed water: 0 mg/L to 200 mg/L Alkaline solutions such as NaClO solution: 0 mg/L to 300 mg/L
	Measurement repeatability	Within \pm 5% of full scale (when temperature, pH and conductivity are constant)
	Display item	Residual chlorine concentration (display range: 0 mg/L to 999 mg/L) Liquid temperature (display range: 0.0°C to 99.9°C) Presence ratio of HClO and ClO ⁻ (display range: 0% to 100%)
	Measurement sequence	Approx. 15 seconds (in redox measuring mode)
Sample conditions	Temperature range	1°C to 40°C
	Temperature fluctuation range	Within \pm 10°C
	Inlet head pressure range	-15 kPa to 100 kPa
	Outlet head pressure range	-15 kPa to 15 kPa (head pressure: about -1.5 m to 1.5 m)
	Consumption	Approx. 12 mL/min (sample self-feeding with built-in pump)
	pH range	pH 4.5 to pH 9.5
	pH fluctuation	Within \pm 1.0 pH in the range of pH 5.0 to pH 8.0 Within \pm 0.5 pH at the other pH values than above
	Conductivity range	10 mS/m to 300 mS/m
	Conductivity fluctuation range	Within 10%

13 Document







13.2 Specifications

Installation	Ambient temperature range	1°C to 40°C
	Ambient humidity range	35% to 85% RH (no condensation)
	Installation direction	Two directions: horizontal and vertical
	Inlet, Outlet shape	Flexible tube OD 6.4 x ID 3.2 mm
Device function	Communication/ Datalog/I/O	(i) Standard model SD card (ii) Digital communication model SD card, RS-232C (iii) Analog communication model SD card, RS-232C Analog output: 2 channels of concentration and temperature, 4 mA to 20 mA Contact input/output: Measurement ON, concentration upper limit error, concentration lower limit error, other errors
	Anomaly detection	Concentration upper and lower limit alarm Liquid temperature upper/lower limit alarm No sample alarm Pump replacement alarm Calibration errors, etc.
	Calibration method	Two-point calibration of tap water (zero) and solution to be measured (span)
	Cable length	(i) Standard model 2 m (ii) Digital communication model 1 m, 5 m, 10 m (iii) Analog communication model Relay cable length between main unit and communication unit: 1 m, 5 m, 10 m
	Waterproof	Equivalent to protection class IPX4 (except DC jack and AC adapter)
	Wetted material	PVC, PP, PVDF, Olefin resin, Diamond, AgCl, Pt
	Other accessories	Tube fitting with filter (1), Tube fitting (1), Rubber feet (1 set)

13.3 Watch the operation in the video



You can confirm the follow operation with a video.

		QR Code	URL
UP-400CL Download content (*Click here for the instruction manual)			https://www.horiba.com/up400cl/downloads/
Screen operation	Zero calibration		https://www.horiba.com/up400cl/zero-cal_en/
	Span calibration		https://www.horiba.com/up400cl/span-cal_en/
	Measurement		https://www.horiba.com/up400cl/measurement_en/
	Display the history screen		https://www.horiba.com/up400cl/history-screen_en/
Maintenance work	Sensor replacement		https://www.horiba.com/up400cl/sensor-replacement_en/
	Pump replacement		https://www.horiba.com/up400cl/pump-replacement_en/

HORIBA Advanced Techno

<http://www.horiba-adt.jp>

2 Miyanohigashi-cho, Kisshoin, Minami-ku, Kyoto, 601-8551, Japan
TEL:+81-75-321-7184 FAX:+81-75-321-7291
