

Smart Pass Management Module Manual



- SV-1081X
- SV-1083X
- SV-1082X
- SV-1084X
- SV-1085X
- SV-1086X

SN

It can be used with access gates and attendance for communities, office buildings, schools, hotels, scenic spots, transportation hubs and other public service places.

Parameters

Camera	Resolution	2 million pixels
	Type	Binocular wide dynamic camera
	Aperture	F2.4
	Focusing distance	50-150cm
	White balance	auto
Screen	Photoflood light	LED and IR dual photo flood light
	Size	8.0 inch IPS LCD screen
Processor	Resolution	800×1280
	Touch	Not supported (optional support)
CPU	Storage	EMMC 8G
		RK3288 quad-core (optional RK3399 six-core, MSM8953 eight-core)
Network module	Audio	Ethernet and wireless (WIFI), NFC
		1.5W / 4R speakers
USB	Serial communication	1 USB OTG, 1 USB HOST standard A port
		1 RS232 serial port
Relay output	Wiegand	1 door open signal output
		One Wiegand 26/34 output, one Wiegand 26/34 input
Wiegand	Upgrade button	Support Uboot upgrade button
		Wired network

2

Function	Credit card reader	None (optional IC card reader, ID card, ID card)
	Face library	Up to 20,000
	1: N face recognition	Support
	1: 1 face comparison	Support
	Stranger detection	Support
	Identify distance configuration	Support
	UI interface configuration	Support
	Upgrade remotely	Support
	Interface	Interfaces include device management, personnel / photo management, record query, etc.
	Deployment method	Support public cloud deployment, privatized deployment, LAN use, stand-alone use
Infrared thermal imaging module	Temperature detection	Support
	Temperature detection distance	1 meter (optimal distance 0.5 meter)
	Temperature measurement accuracy	≤ ±0.5°C
	Temperature measurement range	10°C~42°C
	Visitors' temperature is normal and released directly	Support
Abnormal temperature alarm	Power	DC12V (±10%)
		Support (temperature alarm value can be set)
General parameters	Operating temperature	0°C~40°C
	Storage temperature	-20°C~60°C
	Power consumption	13.5W (Max)

3

General parameters	Installation method	Gate bracket installation
	Size	Standard: 274.24*128*21.48 (mm) IC card / ID card: 296.18*132.88*25 (mm)
Packing list	Machine * 1, power adapter * 1, manual * 1, certificate of conformity * 1	

Installation Notes

1. Module structure description



Optional credit card (ID) version, size: 296.18*132.88*25 (mm)

4

2. Port description

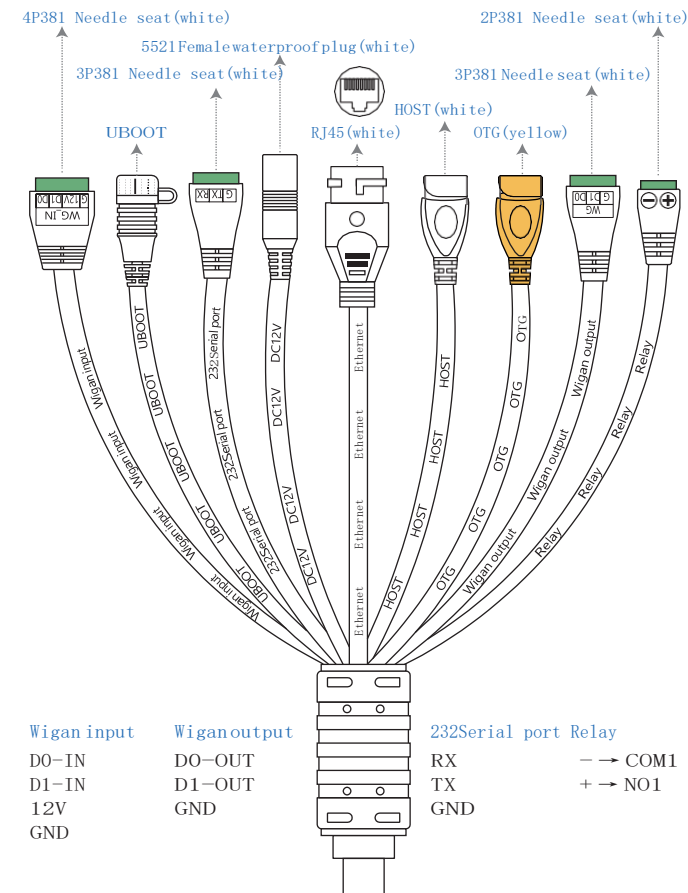

5

3. Installation method (installed with SV-1081X)

① According to the requirements of the installation site, open a 35mm diameter hole (as shown in the figure below) in the space position of the gate (usually the middle or front side).

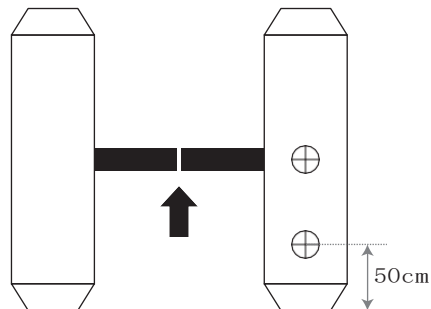

Single channel gate

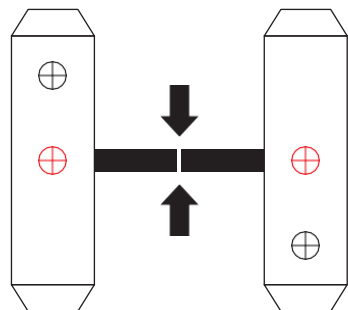

Dual-channel gate

Note: The position of the opening should be based on the actual gate type and scene, and 35mm is for reference only.

② Unscrew the nut at the bottom of the gate head post, thread the cable out of the nut, and remove the nut.



③ Under the gate, insert the cable and cable interface into the gasket and nut in turn, tighten the nut, connect the power supply, and the screen will start.



Note: The brackets in the figure above are for installation reference only, non-standard accessories.

FCC Statement

Federal Communication Commission Interference Statement

This equipment has been tested and found to comply with the limits for a Class B digital device, pursuant to Part 15 of the FCC Rules. These limits are designed to provide reasonable protection against harmful interference in a residential installation. This equipment generates, uses, and can radiate radio frequency energy and, if not installed and used in accordance with the instructions, may cause harmful interference to radio communications. However, there is no guarantee that interference will not occur in a particular installation. If this equipment does cause harmful interference to radio or television reception, which can be determined by turning the equipment off and on, the user is encouraged to try to correct the interference by one or more of the following measures:

- Reorient or relocate the receiving antenna.
- Increase the separation between the equipment and receiver.
- Connect the equipment into an outlet on a circuit different from that to which the receiver is connected.
- Consult the dealer or an experienced radio/TV technician for help.

FCC Caution:

This device complies with Part 15 of the FCC Rules. Operation is subject to the following two conditions: (1) This device may not cause harmful interference, and (2) this device must accept any interference received, including interference that may cause undesired operation.

Non-modification Statement:

Changes or modifications not expressly approved by the party responsible for compliance could void the user's authority to operate the equipment.

Radiation Exposure Statement

This equipment complies with FCC radiation exposure limits set forth for an uncontrolled environment. This equipment should be installed and operated with minimum distance 20cm between the radiator and your body. This transmitter must not be co-located or operating in conjunction with any other antenna or transmitter.

Care and Maintenance

1. During the installation and use of the product, all electrical safety regulations must be strictly observed.
2. When installing on the gate, please make sure that the product is installed firmly.
3. If the product does not work properly, please contact the after-sales service personnel. Do not disassemble or modify the product in any way. (The company does not assume any responsibility for problems caused by unauthorized modification or repair.)
4. Please understand that you are responsible for properly configuring all passwords and other related product security settings, and keeping your username and password properly.
5. If the equipment does not work properly, please do not disassemble it for repair, otherwise it will affect the equipment warranty.
6. Avoid extreme or extreme environments such as extreme high temperature (or low temperature), high humidity, vibration, radiation, and chemical corrosion during installation and use.

Notes

1. This product is not suitable for use in direct sunlight.
2. This product is not suitable for outdoor or semi-outdoor use.
3. The best use environment of this product is indoor, with no wind at 25°C and temperature measurement distance of 50CM.
4. When the ambient temperature is lower than 15°C or higher than 30°C, the temperature measurement error will increase.
5. The measured person should have no strong light source directly on the forehead and face, and no other high/low heat source interference.
6. When the measured person comes from outdoors or from a place with a big difference from the measured ambient temperature, the measured person should stay in the measured environment for at least 5-10 minutes, and then measure the temperature after it is consistent with the ambient temperature. Otherwise, the accuracy of the measured result will be affected.
7. The measured person should keep the forehead dry and not be covered by hair, dust, hats, etc.
8. Temperature measuring equipment can not be placed at the tuyere, because the cold and hot wind has an impact on the accuracy of temperature measuring equipment.
9. Do not place this product near or on high temperature objects.
10. The data measured by the infrared thermal imaging body temperature testing equipment are only used for preliminary screening and cannot be used as medical diagnostic data. Once high body temperature is detected, further screening is required.
11. Calibration method: Please follow the following steps before using this product for temperature screening:
 - a. Measure your own forehead temperature with the traditional calibrated high-precision forehead thermometer in the suitable environment for the use of this product, and assume 36.3°C is obtained.
 - b. Use this product to measure your own temperature in the suitable environment for the use of this product, and assume that the temperature is 36.0°C.
 - c. Repeat step 1 and step 2 more than three times to calculate the difference value between the average value measured by the forehead thermometer and the average value measured by this product. If the error range is within 0.3°C, then this product can be used normally. If the difference value is too large, such as 1°C, then you need to long press the middle mouse button. After the dialog box pops up, enter 123456 to enter the apply settings and set compensation settings in the "Temperature Detection Settings".
12. If you need to upgrade the machine, the power can not be cut off during the upgrade process. The power cut will cause the upgrade to fail, resulting in the failure to upgrade again, which needs to be disassembled.
13. Note: This product is not a medical professional device!

Warranty Card

Dear customer, thank you for purchasing the Face Recognition Pass Management Module. In order to better serve you, please read, fill in and properly keep the warranty card after purchasing the product.

Your name	
Contact person	
Telephone	
Address	
Date of purchase	
Serial number	
Maintenance records	
Cause of issue	

Warranty description:

1. This warranty card is required to be properly kept by the user as a proof of repair.
2. This product is guaranteed for one year from the date of purchase.
3. Warranty Equipment During the warranty period, under normal use and maintenance conditions, the machine itself malfunctions. Upon inspection, the company will provide free repair and parts replacement.
4. During the warranty period, if the following events occur, the company has the right to refuse service or charge materials and maintenance service fees as appropriate.
 - a. This warranty card and valid proof of purchase cannot be provided.
 - b. Product failure and damage caused by improper user use.
 - c. Damage due to abnormal external forces.
 - d. It is not our maintenance service, and the user dismantles it to cause damage.
 - e. Failures and damage caused by natural disasters or other force majeure factors.
 - f. Others intentionally damaged.
5. The company reserves the right to modify and interpret all content.